

NATIONAL HISTORIC PARKS AND SITES BRANCH

MANUSCRIPT REPORT NUMBER 145

REPORT ON THE EXCAVATIONS OF OPERATIONS  
2E13 AND 2E19 AT FORT BEAUSEJOUR

by

A.H. STRYD

(1967)

REPORT ON THE ARCHAEOLOGICAL EXCAVATIONS  
AT FORT BEAUSEJOUR

by

FRANCOIS TRUDEL

(1966)

1966 PRELIMINARY REPORT OF ARCHAEOLOGICAL  
EXCAVATIONS AT FORT BEAUSEJOUR

by

K.A. COLEMAN

(1966)

PARKS CANADA

DEPARTMENT OF INDIAN AND NORTHERN AFFAIRS

Report on the Excavations of Operations 2E13  
and 2E19 at Fort Beauséjour, N.B., 1967.

by A.H. Stryd

Report on the Archaeological Excavations at  
Fort Beausejour, New Brunswick, 1966

by Francois Trudel

1966 Preliminary Report of Archaeological  
Excavations at Fort Beausejour, N.B.

by K.A. Coleman

The Manuscript Report Series is printed in a limited number of copies and is intended for internal use by the Department of Indian Affairs and Northern Development. Copies of each issue are distributed to various public repositories in Canada, for use by interested individuals.

Many of these reports will be published in Canadian Historic Sites: Occasional Papers in Archaeology and History, and may be altered during the publishing process by editing or by further research.

Report on the Excavations of Operations  
2E13 and 2E19 at Fort Beausejour, N.B., 1967  
by A.H. Stryd

TABLE OF CONTENTS

Preface.	vii
Table of Contents.	iii
List of Figures	v
List of Tables.	vi
Chapter One. Introduction.	1
Operation 2E13.	
Operation 2E13 Introduction.	4
Chapter Two. Interpretation and Reconstruction of Operation 2E13.	6
1. Historical Record.	6
2. Structural Interpretation:	6
(a) the casemate floor	7
(b) the casemate walls	11
(c) the casemate roof	17
(d) the casemate entrance	21
3. Conclusion.	27
Operation 2E19.	
Operation 2E19 Introduction.	34
Chapter Three. Description of the Stratigraphy of Operation 2E19.	38
1. Horizontal Stratigraphy:	38
(a) the first stratigraphic unit	40
(b) the second stratigraphic unit	41
(c) the third stratigraphic unit	41
2. The Sloping Stratigraphy.	42
Chapter Four. Description of Features in Operation 2E19.	47
1. Walls:	47
(a) South stone wall	47
(b) North shaped stone wall	49
(c) West compound wall	51
(d) East compound wall	52
2. Counterforts.	55
3. Fireplaces.	57

4. Center stone feature.	59
5. Entrance.	60
6. Wooden remains.	61
7. Exterior brick feature.	63
Chapter Five. The Interpretation of the Stratigraphy and Features of Operation 2E19.	65
1. Historical Interpretation.	65
2. Stratigraphic Interpretation.	67
3. Structural Interpretation:	75
(a) walls	75
(b) counterforts	77
(c) Fireplace(s)	77
(d) center stone feature	78
(e) entrance	80
(f) wooden remains	80
(g) exterior brick feature	81
(h) general	82
References Cited	85

LIST OF FIGURES

<b>Figure 1.</b>	Plan of Fort Beauséjour, New Brunswick, 1967.	3
2.	Photograph of operation 2E13 at the end of the 1966 field season.	4
3.	Photograph of operation 2E13 at the start of the 1967 field season.	4
4.	Plan view of casemate floor with southern half of planking removed to reveal sub-floor construction.	8
5.	Scarf joint in center floor beam.	10
6.	Construction of the right face wall timbers.	10
7.	Right and left face wall timbers prior to removal.	15
8.	Plan view of entrance, south side.	15
9.	Cross-halving joints in the casemate wall timbers.	16
10.	Photograph of casemate roof after excavation.	20
11.	Photograph of the stone drain and the wooden entrance.	21
12.	Profile and partial plan view of wooden casemate entrance.	24
13.	Three artifacts from the casemate, 2E13K.	30
14.	Twelve barrel markings found in the casemate.	32
15.	Location of trenches in operation 19.	35
16.	Photograph of operation 2E19 before excavation.	36
17.	Plan view of operation 19 showing excavated features of barrack at time of departure, August 31.	37
18.	Imaginary cross-section through the width of operation 2E19.	39
19.	Photograph of the North shaped stone wall.	49
20.	Photograph of counterfort # 3.	56
21.	Plan view of fireplace base.	58

LIST OF TABLES

Table 1.	Horizontal dimensions and surface elevations of the trenches of operation 2E19.	87
2.	Lot-layer correlation for the eastern half of operation 2E19.	88
3.	Brick measurements from operations 2E13 and 2E19.	89



PREFACE

The summer of 1967 represented the second consecutive season of excavation at Fort Beauséjour National Historic Park near Aulac, New Brunswick. Excavations were under the direction of Jervis D. Swannack, Jr., staff archaeologist from the National Historic Sites Service, Department of Indian Affairs and Northern Development, Ottawa. The crew consisted of Mr. Jervis D. Swannack, Jr. (chief archaeologist), Miss DiAnn Herst (chief site assistant), Mr. Paul Villeneuve, Miss Winnie Frohn, and Miss Patricia MacDonald (site assistants), Mr. Pierre Nadon (historian), Mr. Martin Fokkema (photographer), Mr. Kerras Campbell (surveyor), and Mr. Frank Korvemaker and myself (student archaeologists). I worked under the direct supervision of Miss Herst and at all times she was in charge of and responsible for the excavations of operation 2E13 and 2E19. Work started on the 15th of May, 1967, and was to continue for two more weeks when I returned to Simon Fraser University on the 31st of August, 1967. The field number "16" was assigned to me by the National Historic Sites Service and all work that I did in the field bears this number, prefixed by the last two digits of the year of excavation, namely, "67".

I would like to acknowledge my indebtedness to Dr. Roy L. Carlson of Simon Fraser University for his valuable comments and the permission to use his draughting equipment. I would also like to express my thanks to Mr. Jervis D. Swannack, Jr. for giving me the opportunity to obtain my first field experience and the skills and knowledge that went with it.

A. H. S.

20 February, 1968  
Simon Fraser University.

CHAPTER ONEINTRODUCTION

Our site was Fort Beauséjour, located in Fort Beausejour National Historic Park near Aulac, New Brunswick. The Fort was built on the western tip of Beauséjour Ridge overlooking the drained marshlands of the Bay of Chignecto and the narrow Missaguash River, which forms the border between Nova Scotia and New Brunswick in this area.

In the 1740's, the ill-defined land known as Acadia was the object of disputed ownership between the French and the British (Nadon 1966). The Missaguash River formed the dividing line between the two spheres of influence on the Isthmus of Chignecto. Fort Beauséjour was started in 1751 by the French as a counteraction to the construction of British Fort Lawrence just across the Missaguash River. In June of 1755, Lieut. Col. Robert Monckton captured Fort Beauséjour for Great Britain and renamed it Fort Cumberland.

After the fall of Quebec in 1759, Fort Beauséjour (Cumberland) lost most of its military significance. It was abandoned and temporarily re-occupied on several occasions, noticeably during the American Revolution and the War of 1812, but it never again became an important fort. Sometime during the 1830's the Fort was abandoned for the final time and the land was leased to farmer-tenants until Fort Beausejour National Historic Park was established in 1926.

Fort Beauséjour has a pentagonal or star shape, formed by five earthen bastions with connecting curtain walls. The bastions were named Prince William, Duke of Cumberland, Prince Edward, Prince Henry, and Prince Frederick by the British, whose entrance was situated between Prince Frederick and Prince William bastions (Fig.1). It replaced the

original French entrance, located between Prince Edward and Prince Henry bastions, which was closed with a curtain wall containing a brick and stone casemate after the French defeat in 1755.

The archaeological excavation system used at Fort Beausejour was an adaption of the system used by the University of Pennsylvania Museum. For the purposes of excavation, there are three spatial units other than the initial site. To quote the Archaeological Excavation System of the National & Historic Resources Branch: "a site is divided into units called (in descending order of size): operation, suboperation, and lot. Ideally, these units should reflect archaeologically meaningful divisions of the site, but, if necessary, they can be used to designate arbitrary divisions such as grid squares. Operations are numbered in Arabic numerals; suboperations are designated by capital letters sequentially within each operation; and lots are labelled with Arabic numerals sequentially within a suboperation" (Rick n.d.: 5). Fort Beausejour is site 2E.

We had at our disposal a considerable amount of historical data about this Fort, in the form of an unpublished manuscript entitled Historical Report on Fort Beauséjour (Nadon 1966).

All wall courses will be numbered from the bottom of the wall to the top. That is, courses towards the base of a wall will receive low numbers while the high course numbers will refer to courses in the upper section of the wall.

Soil color readings such as 7.5 YR; 3/2 or 10YR; 3/4 are based on the color readings suggested in Munsell Soil Color Charts.

All measurements given in this report are expressed in feet and tenths of feet; no inch readings or metric measurements are used.

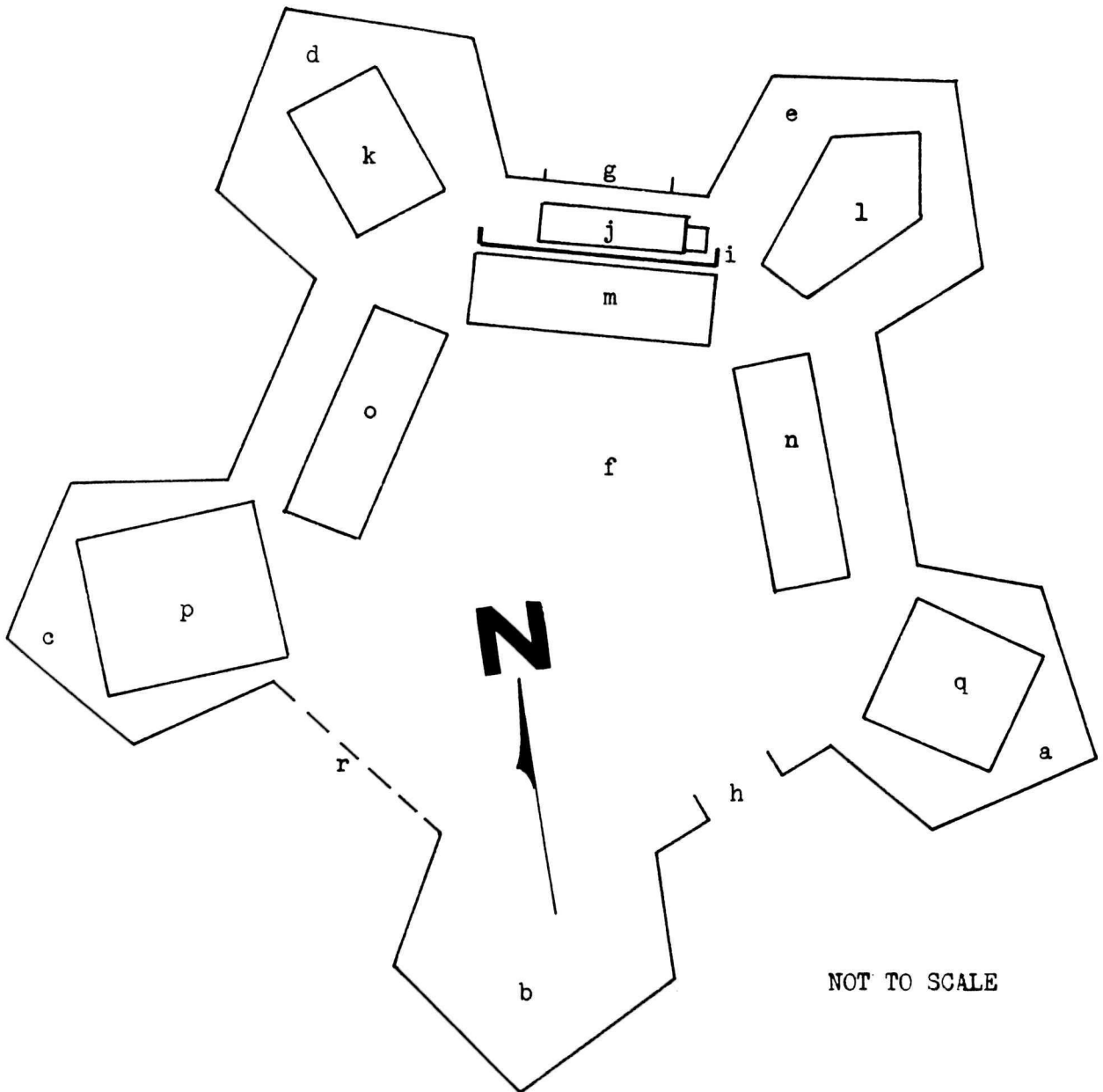

FIGURE 1. PLAN OF FORT BEAUSÉJOUR, NEW BRUNSWICK, 1967.

- |                               |   |
|-------------------------------|---|
| a. Prince Frederick bastion   | j. stone and brick British casemate (2E 12) |
| b. Prince William bastion     | k. French powder magazine (2E 11)           |
| c. Duke of Cumberland bastion | l. OPERATION 13K - French casemate          |
| d. Prince Edward bastion      | m. OPERATION 19 - Officers barracks         |
| e. Prince Henry bastion       | n. men's barracks (2E 16)                   |
| f. parade square (2E 23)      | o. officers' barracks (2E 17)               |
| g. original French entrance   | p. French casemate (2E 18)                  |
| h. British entrance (2E 26)   | q. Stone casemate (2E 20)                   |
| i. Loudoun's battery (2E 12)  | r. torn-down casemate and curtain (2E 21)   |

OPERATION 2E13 INTRODUCTION

Operation 2E13 consisted of the excavation of Prince Henry Bastion. Started in the summer of 1966 by Miss Karalee Coleman and Mr. Francois Trudell, a part of the collapsed roof of a wooden casemate (designated 2E13K) had been exposed when the field season drew to a close. Sub-operations 2E13A to 2E13J, designated to locate the casemate and other features in the bastion, were completed while work had begun on 2E13F. The casemate roof, as well as three test-trenches to the floor, were covered with polyethylene and left to withstand the challenge of a New Brunswick winter. Upon our arrival in May of 1967, we found collapsed and undercut trench walls and nearly all of the roof and polyethylene had been buried by the fallen earth. There did not, however, appear to be any serious damage to the casemate roof.



2E - 1363 X

Fig. 2. Photograph of operation 2E13 at the end of the 1966 field season, looking East.



2E - 86 X

Fig. 3. Photograph of operation 2E13 at the start of the 1967 field season, looking West.

The object of the 1967 work in operation 2E13 was to clean up the damage caused by the preceding winter and to complete the excavations

started by Miss Coleman in 1966. The entire roof had to be exposed and drawn (two shoulder angles had not been uncovered in 1966) followed by the careful removal of the roof to reveal the casemate floor and any artifacts which may have been on it. If time permitted, sub-floor trenching was also planned.

Work in Prince Henry bastion began in the week of May 15-21 and continued for most of the summer. The removal of the collapsed earth and all new extensions to operation 13 were grouped under sub-operation 2E13F while the three floor trenches and all further work on the casemate itself were given lot numbers within sub-operation 2E13K.

The entire roof was cleared off by mid June; the casemate floor with associated artifacts had been uncovered by early July; the floor artifacts had been removed to reveal fairly-well preserved floor planking by late July; and sub-floor trenching was completed in mid August. Although work continued all summer in operation 13, actual excavations proceeded quite slowly since much time was spent in plane-tabling and photographing the casemate in its various stages of excavation.

All reference to the cardinal directions are arbitrary directions rather than true or magnetic readings. Arbitrary east-west runs parallel to the length of the casemate so that arbitrary north actually points in a north-westerly direction.

## CHAPTER TWO

### INTERPRETATION AND RECONSTRUCTION OF OPERATION 2E13.

#### 1. HISTORICAL RECORD.

The casemate of operation 13 was built by the French in 1752 and was probably finished in 1753 (Nadon 1966: I: 1). On the Franquet Plan of 1751 no wooden structures are shown in any of the five bastions except Prince Edward bastion. On the Jonquiere Plan of 1752 however, the casemate is shown and it is present again on the British Brewse Plan dated October, 1755. It is obviously of French origin and probably continued to be used after the British capture of Fort Beauséjour (Nadon 1966).

The French casemate was probably used as such until after the British siege in 1755. Its function during British occupation is of some doubt. An undated plan drawn sometime between 1757 and 1761 gives a clue when it describes the Prince Henry casemate as: "casemate under the Bastion & Curtain...where is kept Provisions and other Stores" (Nadon 1966: plan No. H.M. 15414). Whether the structure played any other roles before destruction cannot be determined from the historical record.

The actual date of destruction cannot be established but after 1776 the timber casemates are no longer mentioned in engineering reports. Complaints of water filtering through earth and timbers and inundating the casemate suggests that they were susceptible to water action and were continually deteriorating. By 1776 they had probably collapsed or had been torn down to prevent accidental collapse and loss of life.

#### 2. STRUCTURAL INTERPRETATION.

The casemate, excluding the entrance, is a five-sided pointed structure with a general "bastion-shape". Its length from salient angle

to the shortest side mid-point is approximately 59.4 feet while its maximum width between shoulder angles is 29.1 feet (Fig. 4). Interior side dimensions are: from the salient angle to the right shoulder angle is 21.6 feet; from the salient angle to the left shoulder angle is 22.5 feet; from the right shoulder angle to the right re-entrant angle is 43.8 feet; from the left shoulder angle to the left re-entrant angle is 40.8 feet; and from the right re-entrant angle to the left re-entrant angle is 10.7 feet.

(a) the casemate floor: the casemate floor covers an horizontal area corresponding to the interior casemate dimensions given above. Vertically, a distinction should be made between the sub-floor construction and the floor proper. The floor will be discussed in terms of this distinction. All sub-floor data is based on the southern half of the casemate for only here was the floor planking removed.

Sub-floor construction consisted of seventeen sleeper beams running roughly parallel to each other in a north-south direction. There is no constant distance between sleeper beams and they vary in width from 0.6 feet to 0.75 feet; the thickness was about 0.5 feet. All but three of the beams (#7, #10, and #17) extend southward to the right flank and face of the structure (Fig. 4).

Along the casemate center line, which runs between the salient angle and the short side mid-point, lies a beam termed the center floor beam. It rests directly on the sleeper beams and measures 0.9 feet wide, 0.45 feet thick, and 53.1 feet long. The beam is somewhat shorter than the casemate so that a gap of 5.6 feet exists between the west end of the beam and the short side of the casemate. The center floor beam is



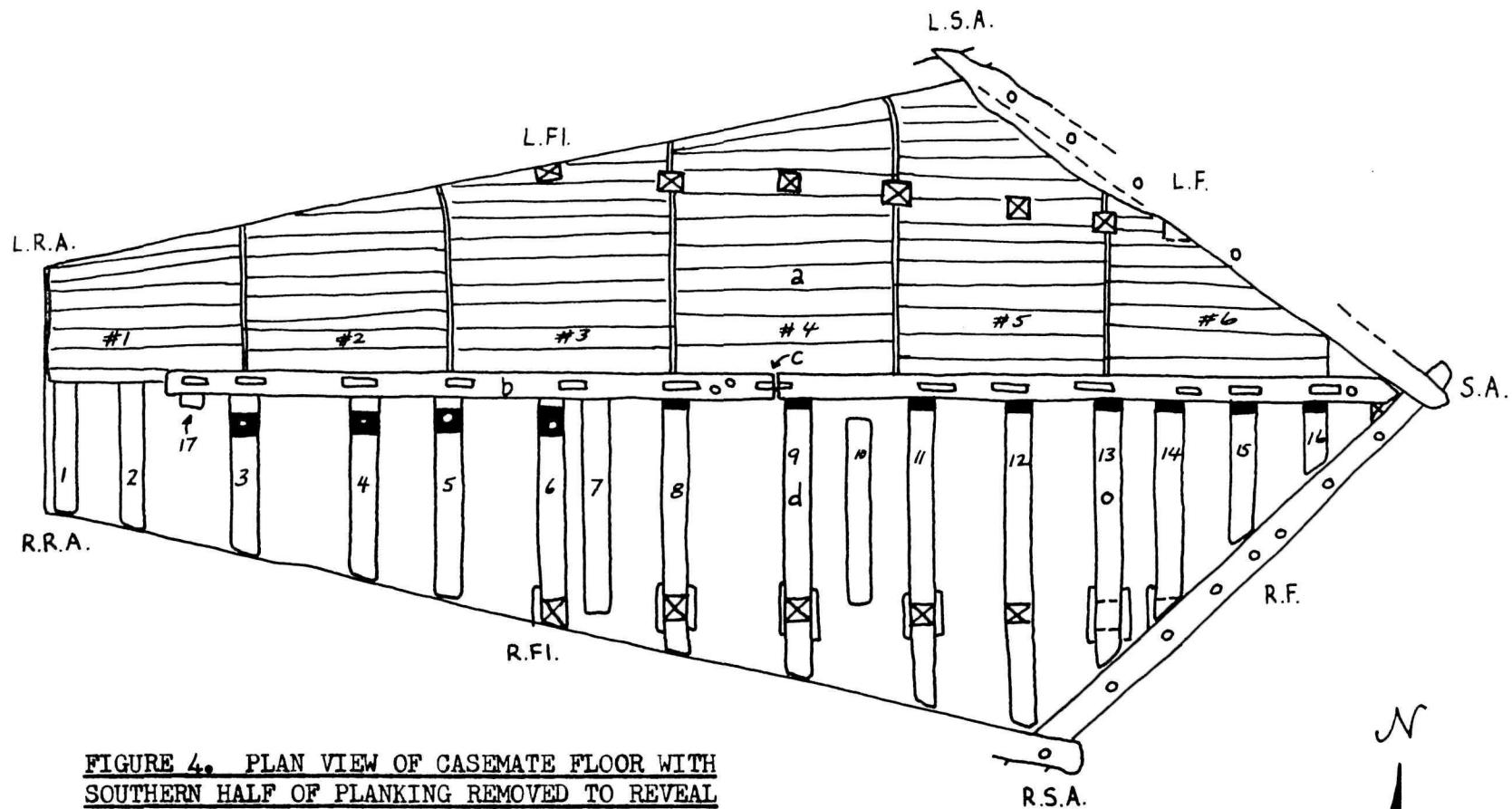

**FIGURE 4. PLAN VIEW OF CASEMATE FLOOR WITH SOUTHERN HALF OF PLANKING REMOVED TO REVEAL SUB-FLOOR CONSTRUCTION.**

- |                      |              |
|----------------------|--------------|
| a. floor planking    | ☒ post base  |
| b. center floor beam | ■ beam notch |
| c. beam joint        | ○ dowel      |
| d. sleeper beam      | ▬ beam slot  |
- S.A. salient angle  
R.S.A./L.S.A. right/left shoulder angle  
R.F./L.F. right/left face  
R.Fl./L.Fl. right/left flank  
R.R.A./L.R.A. right/left re-entrant angle

SCALE: approx. 1 cm. = 3 feet.

constructed of two equal-sized beams placed end to end and joined together. The joint takes the form of a simple scarf joint and is prevented from sliding by two wooden dowels (Fig. 5). Thirteen slots or notches 0.9 feet long and 0.1 feet wide (average), are scattered along the length of the center floor beam. Their function will be discussed in the section on the casemate roof.

Twelve sleeper beams are notched along their upper face. A shallow notch is located in beams #3 to #16, except #7 and #10. In beams #8, #9, and #11 to #16, the notch is located underneath the center floor beam which lies in them. The notches extend several inches beyond the center floor beam, the gap between the floor beam and the edge of the notch being filled by a small piece of wood. This wood, which may also function as a shim, insures a flat surface onto which the floor planking may be nailed. The other notches, which were not located near the center floor beam, were also filled with pieces of wood, and probably for the same reason.

The function of these notches is questionable. Those located directly underneath the center floor beam may have been cut to prevent (or help prevent, with the aid of dowels) the horizontal movement of the beam. They could also be a trough or bed in which the beam could rest and which helped to keep the center floor beam level. Those notches not located directly underneath the center floor beam are apparently without function for they were filled with a small piece of wood flush with the top of the sleeper beams. These notches may have been cut in error and later had to be refilled. Probably the notches were cut as a means of maintaining the horizontal level of the center floor beam. No notches were located underneath the western half of the beam because, due to the slope of the ground and sleeper beams

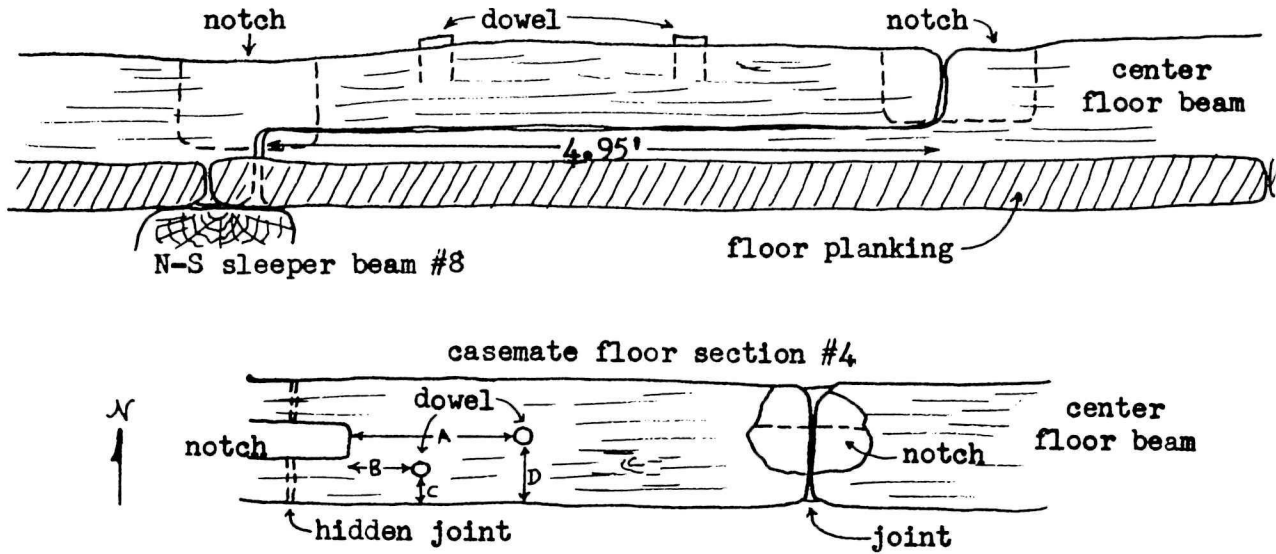

**FIGURE 5. SCARF JOINT IN CENTER FLOOR BEAM.**

Top sketch is side view of the center floor beam looking N. Bottom sketch is plan view of the center floor beam. Neither drawing was made to scale. On the bottom drawing, A = 2.15 feet; B = 0.70 feet; C = 0.30 feet; and D = 0.45 feet.

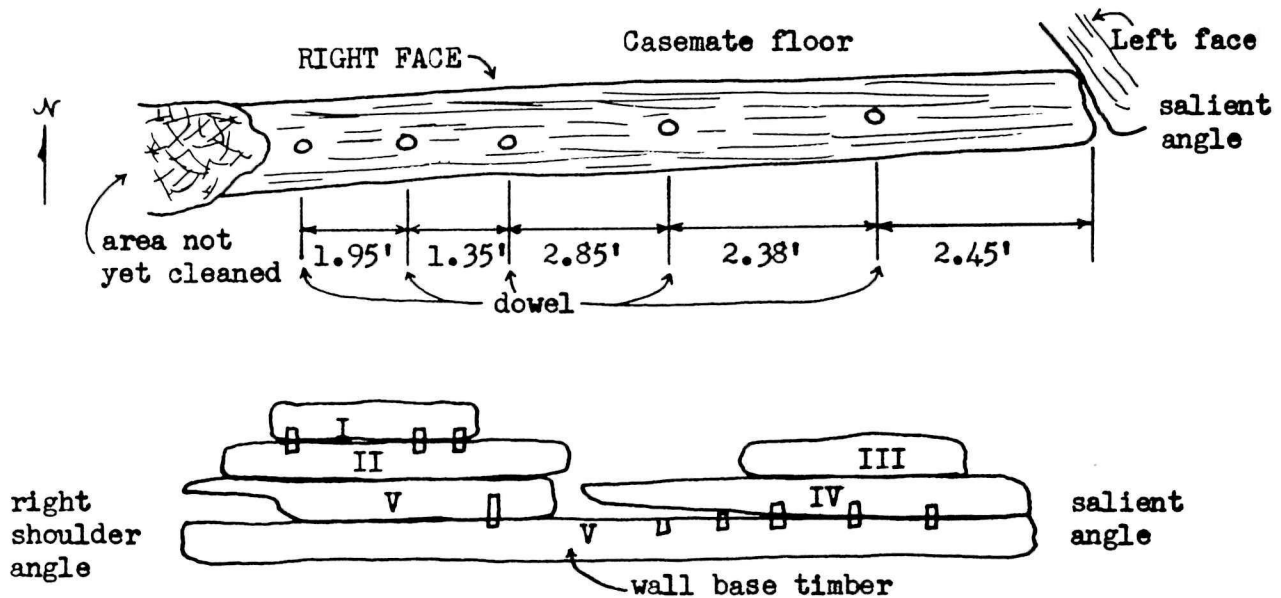

**FIGURE 6. CONSTRUCTION OF THE RIGHT FACE WALL TIMBERS.**

Top diagram, not drawn to scale, illustrates the location of the dowels in the right face wall base timber. The bottom diagram, with an approximate horizontal scale of 1" to 4" and no vertical scale, presents a reconstruction of the right face timbers based primarily on the location of the dowels and dowel holes. Bottom diagram is drawn looking north.

from east to west, the center floor beam was already level by simply resting on top of the sleeper beams.

Where there are no notches directly underneath the center floor beam, the beam lies directly on top of the sleeper beams. Wooden dowels probably joined the sleeper beams with the floor beam. For not only did dowel construction occur along the walls, but those notches which were entirely exposed (that is, in beams #1 to #7, and #17) revealed a dowel hole in the approximate middle of each notch. It appears that dowels were utilized to prevent any possible horizontal movement and it would not be surprising to find wooden dowels connecting the center floor beam and the sleeper beams where the notches are located directly beneath the floor beams as well as where they are not.

The area between the sleeper beams contained innumerable wood chips. The whole area was nearly filled with the wood debitage. It appears that much of the wood shaping that was necessary in the construction occurred right on the location of the casemate.

The entire floor was covered with well preserved one-inch planking in six sections. Plank measurements varied with average dimensions of 0.8-0.9 feet wide and 9.0-10.0 feet long. Square headed nails fastened the planking to the sleeper beams. Usually, there were two nails in both ends of each plank with another two nails near the middle. A few planks have one or three nails in their ends and only one nail in the middle. Part of the southern half of floor planking section #5 as well as the northern half of section #6 had no row of middle nails.

(b) the casemate walls: the casemate had five wooden walls, the shortest of which contained the entrance door. Because there is no definite

evidence as to the exact height of the roof above the floor, we can only approximate the height of the walls. Considering the stature of men in the late 1700's and the fact that the casemate was covered with several feet of earth, it appears that the interior gap between floor and roof probably did not exceed 6 feet and was likely less than that. The Jonquiere Plan (Nadon 1966: appendix 6), entitled Plan et Profil du Fort de Beauséjour, 1752, shows a scale cross-section through an unlabeled bastion which, based on the accompanying description, must be either Prince Edward or Prince Henry bastion. It is a diagrammatic sketch which shows a flat-roofed building about 5.5 feet high and covered with approximately 8 feet of earth underneath the gorge surface. Although this cross-section may not be too reliable, it does confirm the suggestion that the building interior—and subsequently the wall height—was not of enormous proportions and was likely around 6 feet high.

Little remained of the original wall construction; only the bottom timbers near the wall base were uncovered. The remainder had been removed by the destructors of the casemate. Much of the wall wood that was present had been deformed by the weight of the above earth. It appears however, that the wall timbers were squared (certainly the remaining base timbers were) and placed horizontally on top of each other until the desired wall height had been achieved. The average dimensions for the base timbers along the right face was 0.7 feet wide and 0.4 feet thick. Although it is possible that all wall timbers had similar dimensions, some of the right face timbers were thicker than the base timber. They obtained a maximum thickness of 1.1 feet but the width remained the same as that of the base. The area of contact between the two timbers consisted of the

vertical juxtaposition of two squared surfaces (if all the timbers were squared) which insured a tight fit and prevented much water and soil seepage. Because the base timbers were roughly rectangular in cross-section, floor planking, posts, and beams could be placed flush against the wall which increased the strength of construction.

Horizontal movement of the wall timbers was prevented through four methods, three of which can be inferred from the excavated evidence. The first method (which can only be guessed at and is the most doubtful) is the decrease of horizontal movement through gravity caused by the weight of the timbers, the roof, and the surrounding earth. The second method consists of decreased movement due to the corner joints in which two converging walls support each other and prevent sliding. The third method is suggested by the location of three roof support posts. They are situated flush against the wall and would undoubtedly help in the prevention of horizontal log movement. The final and most interesting method reflects an intentional construction technique. Wooden dowels were placed between timbers to stop any movement which might occur between the timbers, but, unlike the second and third methods, the use of dowels could not prevent the movement or collapse of the entire walls. It is possible, therefore, that while the second and third methods were employed to maintain wall stability, the dowels were used to insure the stability of each wall timber (Fig. 6).

The wooden dowels showed some variation in length and diameter but most were about 0.15 feet in diameter and 0.3 feet long. The majority were circular in cross-section although some rectangular dowels were also exposed. In several instances dowels were missing but the dowel holes

were still visible. The dowel technique was most frequent along the right face but it did occur elsewhere, notably along the left face.

The wall joints or corners presented somewhat of a problem. The weight of the bastion earth had deformed much of the softer and rotten wall wood so that it became difficult to determine the construction technique employed in making the corners. Not only had the walls been exposed to tremendous pressures but also the wood chip construction debris which was located along the exterior of the walls had been pressed together into a "mat" or layer of wood pulp. These factors tended to hinder investigation and they had to be carefully removed prior to serious interpretation.

It appears, however, that what was originally suspected was substantiated by later investigations. The shoulder angles were formed by extending and crossing the timbers of the two adjacent walls. To insure stability and proper fitting and to permit the intersection of each log, a cross-halving joint was used. That is, a notch with a depth equivalent to half the thickness of the timber in which it was located was cut into the two intersecting logs. Because the width of each notch corresponded to the width of the other intersecting timber, the two timbers fitted "into each other" and the crossing was accomplished (Fig. 9). Although little was excavated near the salient angle, it appears that this corner was constructed by the same technique. The two re-entrant angles were probably constructed in the same manner except that the logs crossed each other at right angles (measured along the wall interior) rather than the 125-130 degree angles of the two shoulder angles.

Much of the interpretation of the wall structures was hindered by

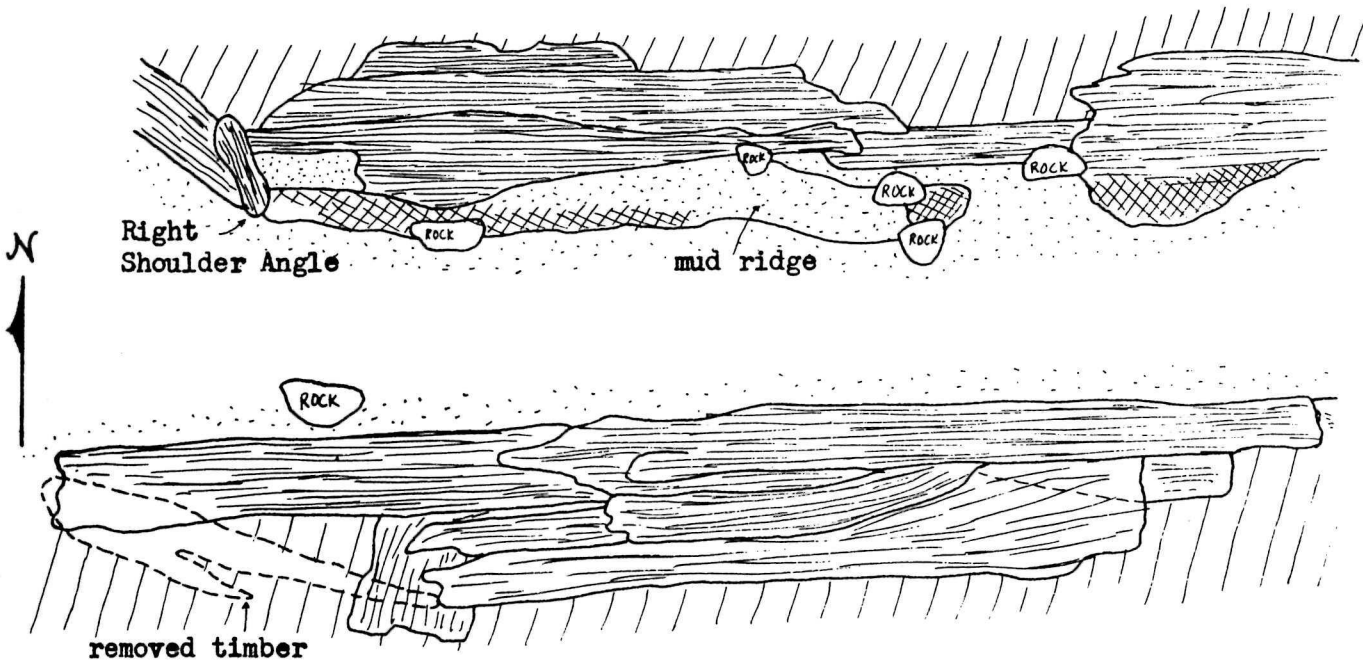

**FIG. 7. RIGHT AND LEFT FACE WALL TIMBERS PRIOR TO REMOVAL.**

Top illustration: right face wall timbers (2E13K6) plan view. Bottom illustration: plan view of left face wall timbers (2E13K4) with one timber removed. Neither drawing was made to scale. Dotted (stipled) areas indicate earth, crossed lines represent compressed wood chips and earth, wide diagonal lines indicate casemate floor area, close lines represent wood fibres.

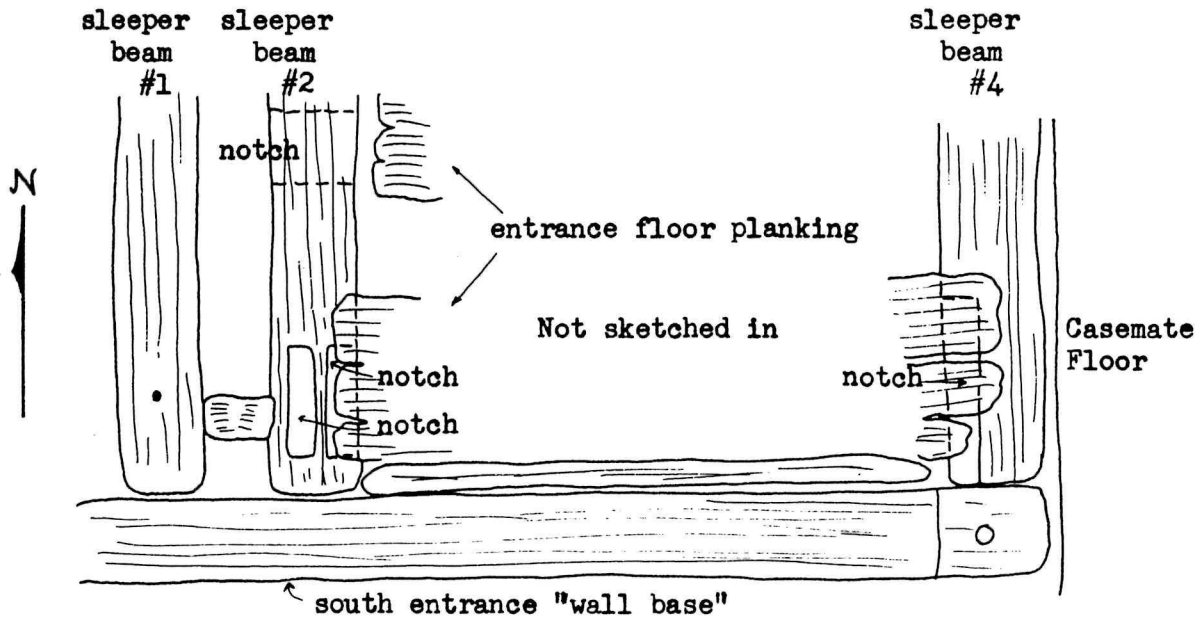

**FIG. 8. PLAN VIEW OF ENTRANCE, SOUTH SIDE.**

Figure illustrates the notching in the southern side of the wooden entrance. Open circle represents a dowel hole, full circle is a nail. Not to scale.



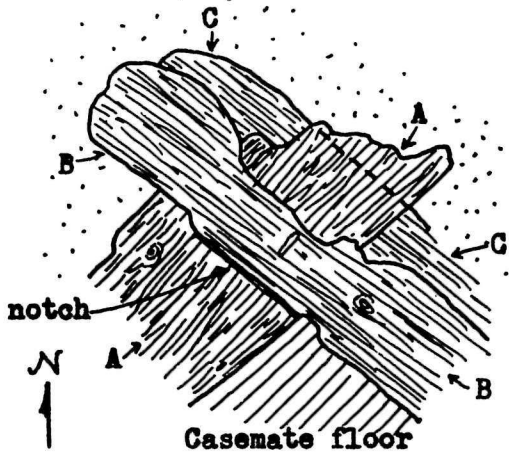

a. Plan view of left shoulder angle.

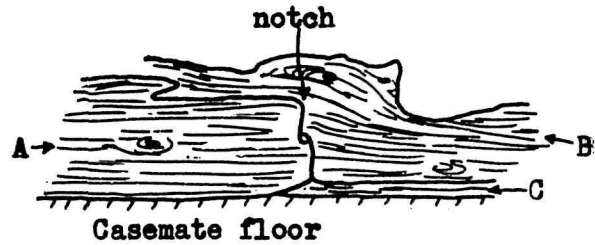

b. Side elevation of left shoulder angle, looking N.

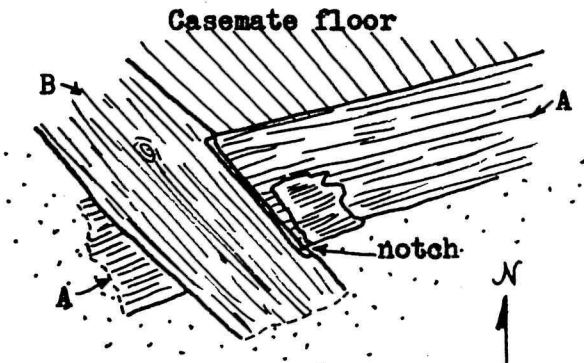

c. Plan view of right shoulder angle.

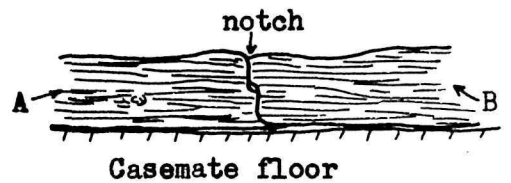

d. Side elevation of right shoulder angle, looking S.

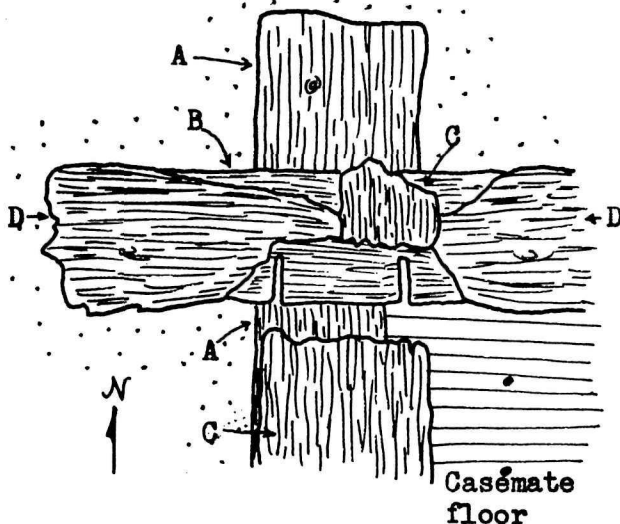

e. Plan view of left re-entrant angle.

**FIGURE 9. CROSS-HALVING JOINTS IN THE CASEMATE WALL TIMBERS.**

Figure illustrates the cross-halving joints that were used in the right shoulder angle (c and d), left shoulder angle (a and b), and the left re-entrant angle (e). The timbers are lettered so that the plan and side elevation views may be compared and to help in distinguishing the location of individual timbers. Nails are black dots; soil is stippled. Scale: 1" to 1'.

lack of evidence. Excavations yielded but the bases of the five walls and only along the left and right faces was there any more. Here, parts of the first two or three logs were uncovered but they were deformed through pressure and had collapsed towards the building interior (Fig. 7). The best indications of dowel use came from these two areas but they yielded very little additional information about wall construction (Fig. 6).

It is interesting to note that this absence has a positive aspect as well as a negative one. It appears that preservation conditions were quite good in Prince Henry bastion and this is supported by the well-preserved floor and sub-floor as well as the roof remains. Given this fact, it is unlikely that the walls "fotted away". Instead, the walls were probably intentionally removed; the timbers may have been used in other building construction. The wall absence suggests that the casemate was intentionally abandoned. Remembering complaints of continued casemate inundation due to water seepage through the roof (Nadon 1966: I: 1). I would suggest that water control became such an enormous problem that the casemate was abandoned and intentionally torn down to prevent accidental collapse.

(c) the casemate roof: according to the historical record, twelve inch or fourteen inch square timbers of spruce were used in the roof construction (Nadon 1966: I: 4). In DeFiedmont's Journal of the Siege of Beauséjour it states that "double roofing of the same timbers was gabled, but to save time, some of the timbers were laid like lintels on rows of posts encased in heavy planks" (Nadon 1966: I: 4). De Fiedmont's statement was about the casemate roofs in general rather than any specific casemate roof. Apparently, the French constructed both gabled

and flat roofs and it became our problem to discover which was employed for the Prince Henry casemate.

The 1967 field season completed the roof excavation started in 1966. When fully exposed, it was apparent that the roof had been flat and NOT gabled as reported by Miss Coleman (1966). Nowhere were there indications of a pitched roof. No rafter timbers, which are characteristic of gabled roofs, were found nor was there any evidence of a center roof beam. Instead, a mass of rough logs were uncovered running north-south. They were unworked with only the branches trimmed off and no planks were visible. In some areas, noticeably between the two shoulder angles, the roofing remains were scarce for many of the roof timbers were missing while in other regions the logs were pressed together into a layer of wood fibre.

The most noticeable feature was the rough nature of the roof timbers. Many continued from one side of the casemate to the other with no break in the middle. Pitched roofs, even after collapse, display a crack or break in the roof timbers where the apex of the roof and the center roof beams (ridgepole) ran. Usually, two separate sets of timbers--one for each roof side--are used for pitched roofs but the excavated timbers did not have this dichotomy. It was quite evident that the original roof structure was flat and not gabled.

At one time, the roof may have been supported by as many as thirty-one uprights of varying sizes. The function of some of these may be questionable, but we do have direct evidence for fourteen posts which can be associated with the support of the roof. The fourteen are illustrated in Fig. 4 and are situated in two irregular rows, one on each side of the

center floor beam. Each post is situated in a post hole in the floor planking and rests on a sleeper beam. Beside each sleeper beam where the posts are located there are two pieces of wood which offer extra footing for the posts. The wooden pieces vary in size, with one piece located on each side of a beam. In the south-east corner there are two empty post holes in the floor planking with beams directly underneath. Obviously, two posts which were removed prior to or after the roof collapse originally stood here. A similar empty post hole occurred in the north-east corner near the left face wall timber.

The eleven roof support posts which are actually present show little variation in dimensions although they are not identical. Two are square in plan view but the majority are rectangular. North-south measurements range from 0.65 feet to 0.90 feet with 0.75 feet as average while east-west readings vary from 0.45 feet to 0.90 feet with 0.76 feet as average. The posts were no longer than one foot. They had all been broken off near their bases; no cut posts were present. The post holes were often square and were only a little bit larger than the posts. Average post hole dimension is 0.85 feet square.

The notched center floor beam is probably also involved in the support of the roof. There is some evidence to suggest that the thirteen notches or slots in the center floor beam held roof support posts. The slots are certainly not related to either floor or sub-floor construction. A probable post was found lying on the floor. One end, which was lying on top of the floor beam and was adjacent to a notch, had a wooden tenon with dimensions nearly identical to that of the notch. It seems very likely that these functioned as a simple mortise and tenon joint with the post supporting the

roof. Similar posts probably filled each slot. This would offer valuable support down the casemate middle and in the western third of the structure.

Other possible roof support posts include the remains of an upright, 0.55 feet N-S and 0.65 feet E-W, located at the salient angle where the center floor beam meets the right face wall timber. A second post, somewhat smaller is located in the sixth section of casemate floor planking, sixth plank north of the center floor beam. It measures 0.30 feet NW-SE and 0.15 feet NE-SW. A very small third "post", 0.10 feet E-W and 0.13 feet N-S, is situated in the middle of the fifth plank north of the center floor beam in the sixth section of floor planking. The top of this "post" is flush with the floor planking and it may be a broken off eyed, pointed piece of wood (to be described). And finally, a small post measuring 0.35 feet N-S and E-W is located in between planks under 4 and 5 north of the center floor beam in the second section of floor planking.



Fig. 10. Photograph of casemate roof after excavation, looking west.

(d) the casemate entrance: this section will include two different but related features. They are the wooden entrance proper which lies adjacent to the shortest side of the casemate and the stone drain which runs westward from the wooden entrance (Fig. 11).



Fig. 11. Photograph of the stone drain and the wooden entrance, looking west.

2E - 334 X

The stone drain was formed by two rows of field stones which started at the NW and SW corners of the casemate entrance and converged to form a narrow trough. The feature has a general funnel shape with the small opening pointing westward. A third row of field stones, only four stones long, runs down the middle of the drain from the wooden entrance to the point of convergence. All three rows have a similar elevation for their upper surfaces (N-S) while there is a decrease of about 0.4 feet in elevation from east to west (the ground itself slopes 1.0 feet from east to west). The trough is stopped abruptly by the East compound wall exterior face of

operation 2E19 Officers' Barracks. Apparently, the drain continued further westward at the time of its construction but the later erection of the Officers' Barracks severed the drain. It had probably ceased to function by that time. Finally, small pieces of wood with dimensions no greater than about 0.5 feet wide and 1.5 feet long were uncovered between the drain stones. No nails were found but the wood did resemble small rotted planking.

Initially, we were at a loss in explaining its function; we could not even name it. Since we could not attach a functional name, the drain was given the morphological label of "Y" stone feature. It took an extremely rainy day to verify an original suspicion that these stone may have functioned as a drain. The stone feature insured water control by draining the immediate area around and under the wooden entrance. It is also possible that the water level underneath the casemate floor planking was indirectly controlled by the drain through its control of the entrance water. Since people walking to and from the entrance would have to cross the drain, it was probably covered with wooden planking—the wood fragments found between the stones. The short middle row of stones, which apparently has no draining function, was probably placed there to support the longer planks which ran across the wide opening of the drain.

The wooden entrance measures 6.8 feet E-W and 6.0 feet N-S. It is located near the middle of the short west casemate wall. Nothing but a decayed floor or platform remains; there is little left of either wall or roof, if there was any to start with (Figs. 8, 12).

Two roughly squared timbers, each about 6.8 feet long and 0.5 feet wide, project westward from the west casemate wall base timber. They also appear to be wall base timbers, but for the entrance walls.

Four small sleeper beams run N-S between them. They average about 5.0 feet long, 0.55 feet wide, and at least 0.5 feet thick. These six timbers form the base of the entrance and the entrance sub-floor construction. These timbers are not connected to the casemate. A small gap of approximately 0.15 feet exists between the entrance timbers and the west casemate wall base.

It appears that floor planking as thick as the casemate planks covered the entire entrance floor at one time. Much of the planking can still be seen even though it has greatly decayed and has collapsed between the sleeper beams. Iron nails prevented the boards from moving, for several nails can still be seen. The floor remains are situated from on top of the second sleeper beam to on top of the west casemate wall base. If the planking did not cover the entire entrance it certainly covered everything eastward of the second sleeper beam. It should also be noted that the floor planking extended beyond the entrance proper and onto the west casemate wall base which has a similar elevation. Nails fasten the floor boards onto this wall base so that these planks become the connecting element between the entrance and the casemate.

The rotted bases of four posts were exposed in excavation. Two were located between the first and second sleeper beams adjacent to the north and south entrance wall base respectively while the other two posts were notched into the top of the west casemate wall base. The notching occurred in the form of a mortise and tenon joint with the tenon as an extension of the west face of the post (Fig. 12). The eastern end of the floor planking is located between these two posts while there is very little planking between the first two posts. The non-notched posts



**FIGURE 12. PROFILE AND PARTIAL PLAN VIEW OF WOODEN CASEMATE ENTRANCE.**

Figure shows profile through entrance looking North at top of page and plan view of northern third of entrance on the bottom. Line X-Y shows location of profile on plan view. Scale is one inch equals one foot.

- |                             |                         |                   |
|-----------------------------|-------------------------|-------------------|
| a. west casemate wall base  | f. sleeper beam #3      | l. entrance floor |
| b. casemate floor planking  | g. sleeper beam #4      | ▣ earth           |
| c. entrance "wall base" (N) | h. notched post (N)     | ▨ wood            |
| d. sleeper beam #1          | j. non-notched post (N) | m. roof(?) wood   |
| e. sleeper beam #2          | k. mortise notch        |                   |

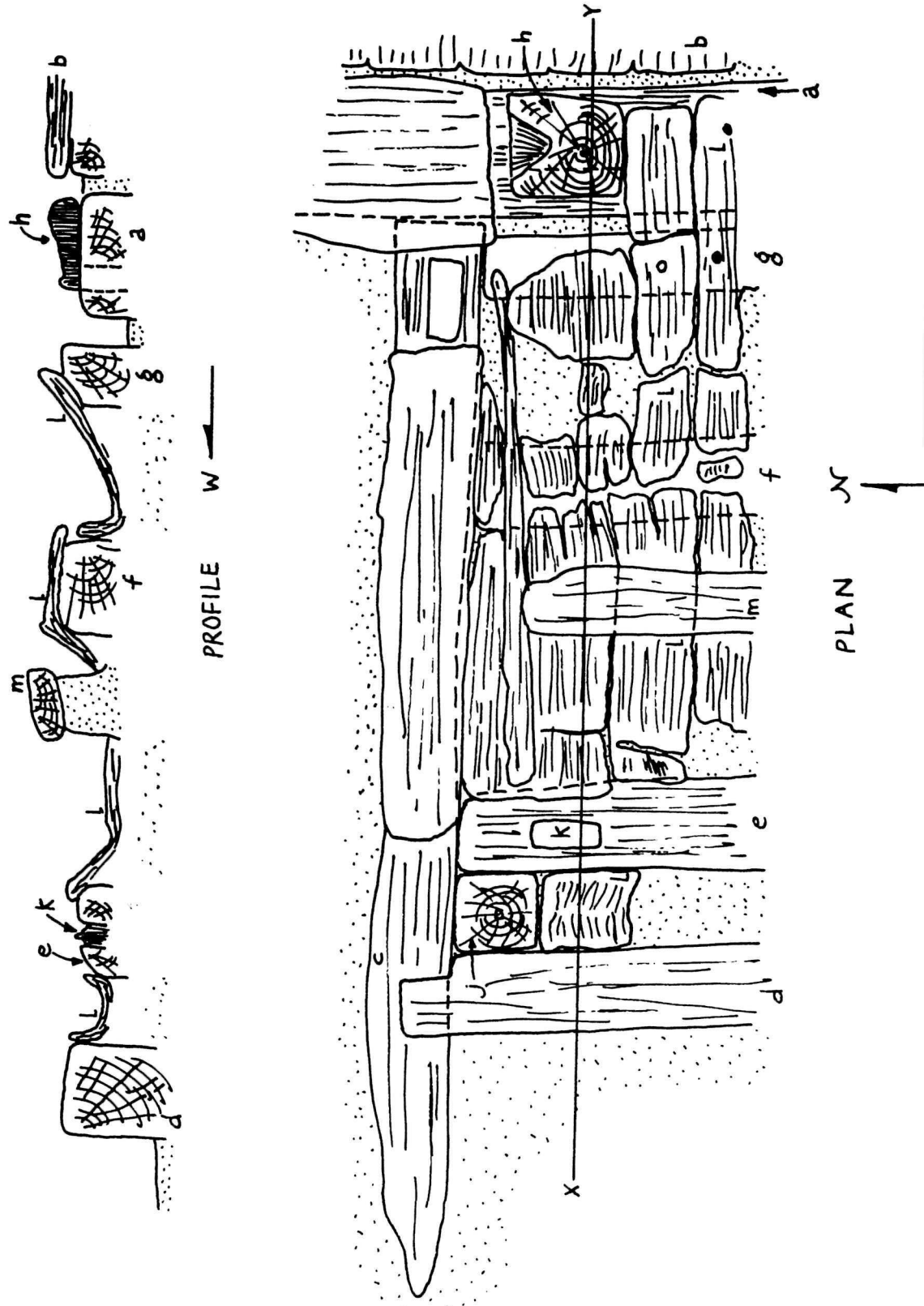

measure 0.45 feet square while the notched pair probably were 0.8 feet long (N-S) and 0.6 feet wide. They are badly decayed and measurements are partially based on notch dimensions.

Four mortise notches other than those used with the posts are visible. Two are located in the second sleeper beam while there is one in both of the entrance wall timbers (Figs. 8, 12). All measurements read about 0.5 feet long and 0.15 feet wide. Broken off tenons remained inside the mortise notches so that no depth readings were available. An empty dowel hole (0.05 feet deep) was located in the middle of the south wall base timber, 0.33 feet from its eastern end.

The entrance may have had a roof and walls or it may just have been a platform outside the casemate. There is really very little evidence for either hypothesis. No wall or roof remains were uncovered like they were for the casemate itself. The evidence which suggests that there was a roof and walls includes the four posts which may have supported a roof, the four notches which obviously held some form of upright, some deformed wood fragments about three feet long located along the two wall bases which may be wall remains, and a shaped piece of wood 4.5 feet long, 0.45 feet wide, and 0.2 feet thick which is located ON TOP of the floor planking and as such may have come from the roof (Fig. 12). I think, however, that the entrance probably consisted of a platform which had neither walls nor a roof. My general interpretation of the entrance and my supporting evidence is as follows.

A wooden walk located on top of the drain stones led to an entrance platform which in turn led into the casemate via a wooden door located in the middle of the west casemate wall. The two squared posts that were

notched into the top of the west casemate wall base timber probably served as the vertical posts for the door frame. The two features—the entrance and the casemate—were connected with nailed planking which covered the entrance platform as well as the west casemate wall base timber. The other two posts, located in the western half of the entrance, were not notched into any timbers and it is unlikely that these posts could have ever been able to support the weight of a roof or walls. In comparison with the two larger and notched posts in the eastern half, these two uprights probably reflect a decrease in functional importance. They may have been used to stabilize the foundation or to space the entrance sleeper beams.

The function of the four empty notches is questionable. They too may have held posts at some time but all four are about 0.3 feet shorter than the two notches in the west casemate wall which contain upright remains. Possibly they contained smaller uprights which supported a roof or a wall although it is not likely that uprights would be placed in notches located on a wall base if there was to be a wall. Another alternative is that these smaller notches contained short uprights for a railing which ran along the edge of the platform entrance. Although it is very possible that the wall and roof timbers of the entrance were removed (like many of the casemate timbers were), the absence of any definite wall or roof remains (except possibly one small piece described above) should strengthen the argument for a platform entrance.

Finally, I would also suggest that the area between the "wall base" timbers west of the first sleeper beam was covered with planks running N-S rather than E-W like the rest of the entrance. They would be similar to the planking that may have been on top of the drain. This seems to be

a logical possibility since: (a) the 2.5 foot gap between the probable planking of the drain and the present planking of the entrance floor, which started at either the first or second sleeper beam, would need to be covered, and (b) there is no sleeper beam at the western extremity of the two "wall base" timbers to support any E-W planking while these "wall base" timbers could themselves support N-S planking. The possibility of alternative explanations should not be ignored but the evidence in support of any interpretation will be meagre because little else than a wooden floor was found.

### 3. CONCLUSION.

The history of the casemate, 2E13K, is better documented in the historical record than that of operation 2E19. Structural and historic data was to be found in Nadon's Historical Report on Fort Beauséjour (1966) and much of it was substantiated by the excavated evidence. In areas of conflicting information, such as if the roofs were gabled or flat, our work provided many of the answers. Not all questions were answered, however, and one of the most interesting was the date and reason for the destruction of the casemate.

The casual factors of destruction could have been many and varied. One dominant reason may have been present or a number of minor causes may have been at work. We do know that water seepage had been a tremendous problem (Nadon 1966: I: 1). The roof was apparently not water tight and occasional casemate floodings were reported. It is possible that continued seepage destroyed much of the casemate's superstructure (walls, roof) and that the structure finally became unusable and had to be abandoned. Most of the destruction occurred in the superstructure while the direct

contact of the floor with the damp earth and marsh mud resulted in the good preservation of the floor.

Even with rotted timbers, the casemate would probably have not been abandoned had there not been a decrease in its functional importance. Only when there was very little need for it as a place of storage would it have been voluntarily abandoned without making attempts at its reconstruction (there is no indication of this in the historical record). A possible alternative is that a need for construction timbers coupled with a decrease in need for an old French casemate caused the British to intentionally tear down the structure. The wall timbers, all but one of the center support posts, and the main roof beams were only missing; the floor timbers were not taken.

Assuming that the causal factors are probably related to rotting of the superstructure and a decrease in functional importance, we need to question the nature--the "how"--of destruction. Was the casemate intentionally torn down, did the roof collapse by itself, or did part of the structure collapse and its destruction was completed by the British? Again, we have no direct evidence but two things should be noted: all the interior roof support posts that were located on the floor were broken off near their bases; and the floor was covered with numerous barrels and other artifacts.

The artifacts inside the casemate were primarily found directly on top of the floor although some were located between the collapsed roof timbers and the floor. These artifacts showed some variation in function and material but they displayed a limited range of variation in comparison with the Fort Beauséjour barracks.

Military artifacts uncovered included cannonballs, mortarshells and musketballs of varying sizes, smaller lead drop shot, and gunflints which usually had a honey color. Domestic or trade goods such as wooden combs (and comb fragments), ladles, razors, knife handles, and a variety of small colored glass beads were also found. It appears that the domestic items, especially the combs and razors, were primarily (but not exclusively) located on the floor in the vicinity of the left shoulder angle. Several leather goods, noticeably 2 leather boots, were also uncovered.

Several artifacts which were exposed could not be identified. These included a possible wooden door, some wooden shafts which resembled tool handles, and several rather unusual objects which we labelled pointed, eyed pieces of wood (Fig. 13).

The "door" was located on top of the floor along the left face near the left shoulder angle. It consisted of two broad boards (badly rotted) nailed at their ends into two cleats each about 0.85 feet wide. The "door" is rectangular in shape and measures approximately 3.5 feet long and 2.9 feet wide. All planking is 0.08 feet thick; no hinges or handles were visible.

One of the possible tool "handles, which may be considered representative of all the "handles" uncovered, was measured. It was 2.65 feet long, 0.18 feet wide at its wide end, and 0.14 feet wide at the narrow end. The stick was not tapered; instead, it had a long slender shaft (0.14 feet thick) which suddenly widens into a thicker base. This was 0.6 feet long and 0.18 feet thick. A cross-section would reveal a roughly circular base and triangular shaft with the apex of this triangle located on the same side as the wider base (Fig. 13). These pieces of wood may have

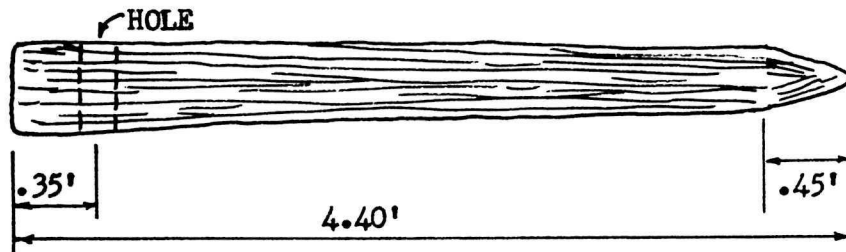
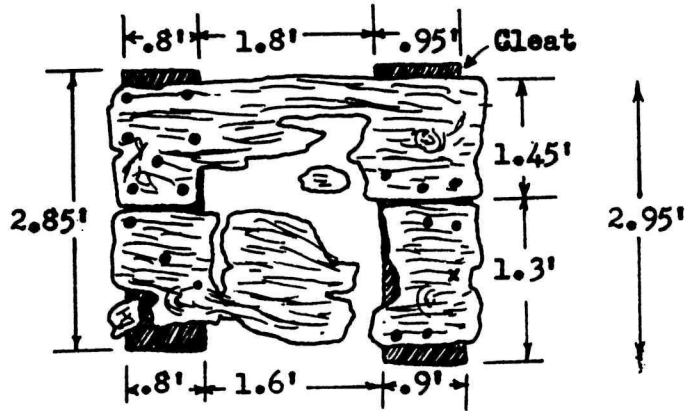

**FIGURE 13. THREE ARTIFACTS FROM THE CASEMATE, 2E13K.**

Top illustration: The possible door found near the left shoulder angle, plan view. Black dots represent nails; the "x" represents one nail which was found in the cleat only; the striped wood are the door cleats. Scale: 1" to 2'.

Middle illustration: a possible tool handle, plan view. Not to scale.

Bottom illustration: a pointed, eyed piece of wood with unknown function, plan view. Note gentle taper of two sides with steep taper of four sides at one end. Also note the position of the hole relative to the tapered sides. Not to scale.

functioned as pick or axe handles in which case the wide base would presumably be inserted into an opening in the metal tool. The thin shaft would be held in the hand.

Several pointed, eyed pieces of wood were found. Again, one representative piece was measured. It was 4.4 feet long, roughly square in cross-section, and has a round hole (0.09 feet diameter) located 0.35 feet from its widest end. A gradual taper occurs along two sides from the wide end to a point 0.45 feet from the opposite end. Here, the taper increases sharply and all four sides now slant inward to form a dull point. The hole in the wide end was always located between the two gently tapering sides; that is, the hole runs from one of the two sides to the other. Their function could not be determined.

Finally, an anvil (uncovered in 1966), a badly corroded lock, a screwdriver, and a grooved metal plate were found. The most abundant artifact, however, was the wooden barrel. None were found intact because of the collapsed roof but many barrel bottoms and tops as well as barrel staves were uncovered. A few wooden barrel hoops were also present. Although I am not aware of the actual barrel total, at least seventy-two were counted by myself. The barrel ends averaged 1.4 feet in diameter. Seventeen of the barrel ends had markings (initials, numbers, etc.) burned into them; these may have been the manufacturer's trade mark (Fig. 14). The fragment of a "giant" barrel with a diameter of at least twice that of the regular barrels was found but no additional data is available to me. None of the barrels excavated this summer contained any products although last summer two barrels with an unidentified white "chalky" substance were found.

The fact that there were so many artifacts inside the casemate suggests



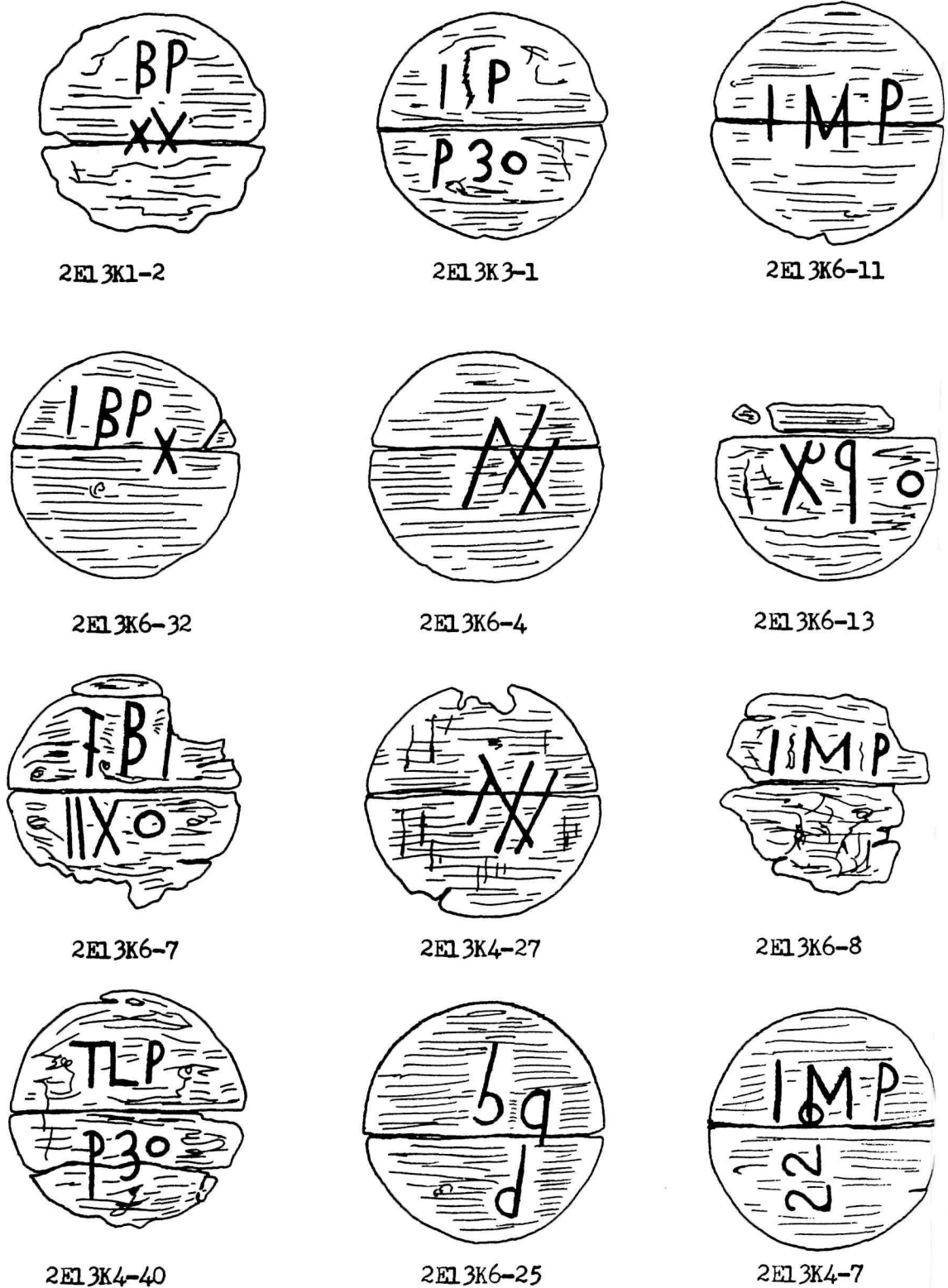

**FIGURE 14. TWELVE BARREL MARKINGS FOUND IN THE CASEMATE.**

Figure illustrates twelve of the seventeed marked barrel bottoms/tops found on the casemate floor. Artifact numbers below each barrel; scale is one inch equals one foot.

that the roof accidentally collapsed. It is unlikely that a military garrison would have left a significant portion of their supplies within a building as they were about to tear it down. Even empty barrels would have been saved as much as possible. The presence of the artifacts seems to suggest that the structure accidentally collapsed and that the remaining wall timbers were later used by the British for other purposes.

One bit of evidence which does not easily fit into the above interpretation is the absence of the interior roof support posts (except maybe one). Had the entire roof suddenly collapsed, we could expect to find these posts between the roof and the floor. They were all missing and it appears that they were intentionally removed prior to collapse. For if they were removed through the thick roof after collapse, why weren't many of the artifacts also removed? Of course, we have no knowledge of the original total of implements and maybe many of the more important artifacts were removed.

OPERATION 2E19 INTRODUCTION

Operation 19 consisted of the excavation of the remains of a building--possibly an Officers' Barracks--located on the parade square just to the south of and adjacent to the British stone and brick casemate (Fig. 1). Miss Herst was in charge of the total excavation while I was responsible for the eastern half of the operation. At the time of my departure (August 31), the eastern half had essentially been finished while the western half still required some work. The entrance way as well as the western half of the South stone wall still needed to be dug.

As in operation 13, all directions are arbitrary ones. Arbitrary east-west runs parallel to the length of operation 19 while arbitrary north points in an actual north-easterly direction.

Operation 19, measuring a maximum of 84 feet east-west and 51 feet north-south, was excavated in twenty sub-operations labelled 2E19A to 2E19V (the letters I and O were omitted to prevent any possibilities of confusion with the numbers 1 and 0 in the field notes). There were fifteen trenches, 19A to 19P, and 19V. Sub-ops 19Q and 19R consisted of the 3-foot wide balks situated between the trenches while sub-ops 19S, 19T, and 19U were vertical (downward) extensions of the fifteen trenches after their initial completion (Fig. 15; Table 1).

There were no indications prior to excavation as to the exact location of the building which we were planning to dig. There were neither noticeable depressions nor outstanding ridges along the ground. Instead, the surface was quite regular as indicated by the surface elevations of the southern sub-ops 19A, 19D, 19E, 19G, 19K, 19L, and 19P. The northern sub-ops are partially situated up the earth embankment of the British casemate and their surface elevations (at least the NW and

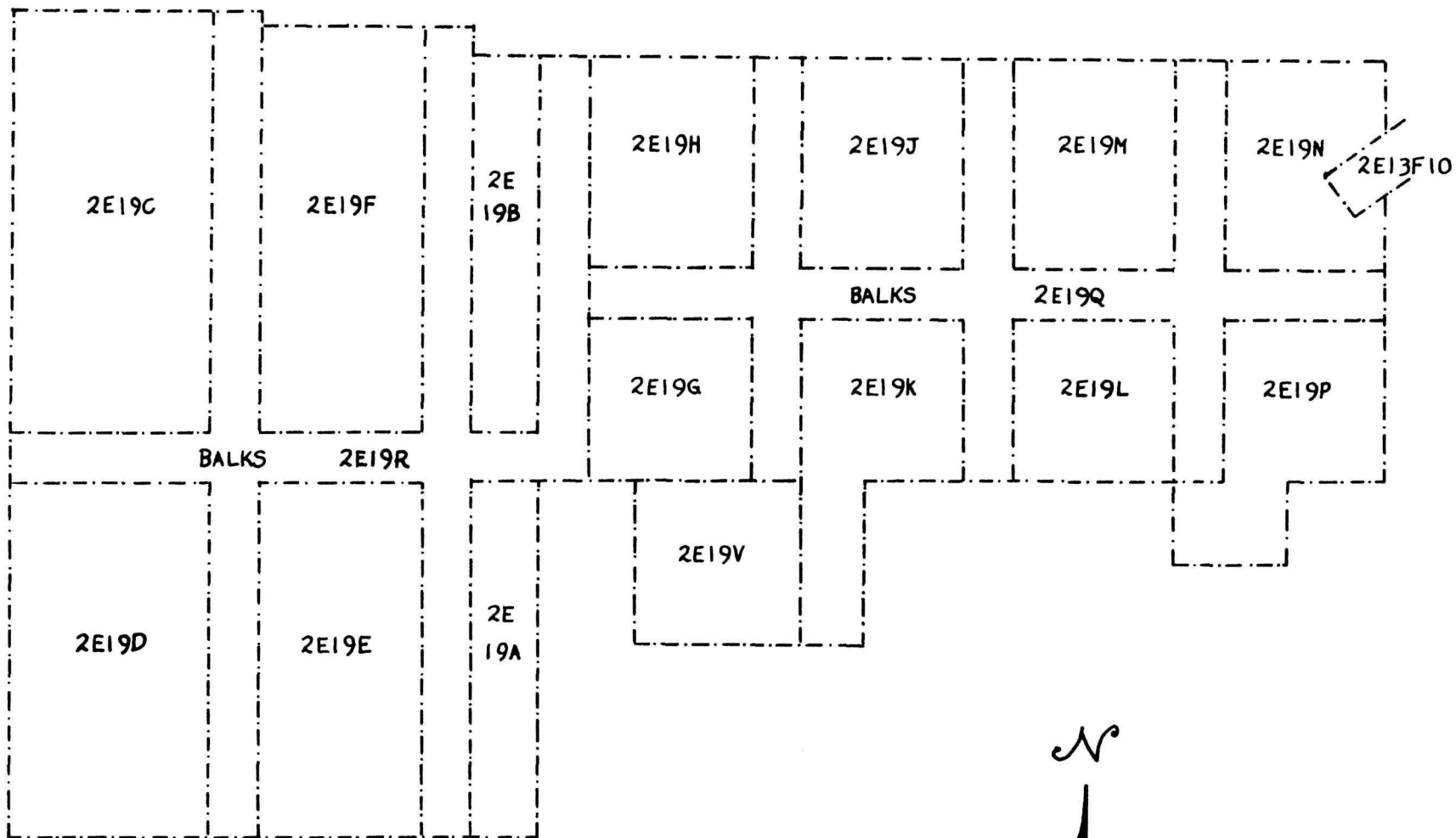

FIGURE 15. LOCATION OF TRENCHES IN OPERATION 19.

Figure shows the location of sub-ops 2E19A to 2E19V except 2E19S, 2E19T, and 2E19U which are downward extensions of the trenches. Note that the balks are divided into two sub-ops, 2E19Q and 2E19R. Scale is one inch equals ten feet.

NE corners) are not, therefore, a valid indication of the level terrain located to the south of the casemate embankment (Table 1).



Fig. 16. Photograph of operation 2E19 before excavation, looking northeast. Operation 2E13 in right background.

2E - 45 X

By August 31st most of the wall remains and the larger features had been uncovered. The probable entrance to the building had also been exposed and a new sub-op, 19V, was started to complete the excavation of this feature. Fig. 17 illustrates not only the state of excavation on August 31 but also what still needed to be done. Sub-ops 19A to 19C, 19E to 19J, 19L to 19N, and 19Q had been completed while 19D, 19K, 19P, 19R, and 19S were near completion. Three sub-ops, 19T, 19U, and 19V, had just been started.

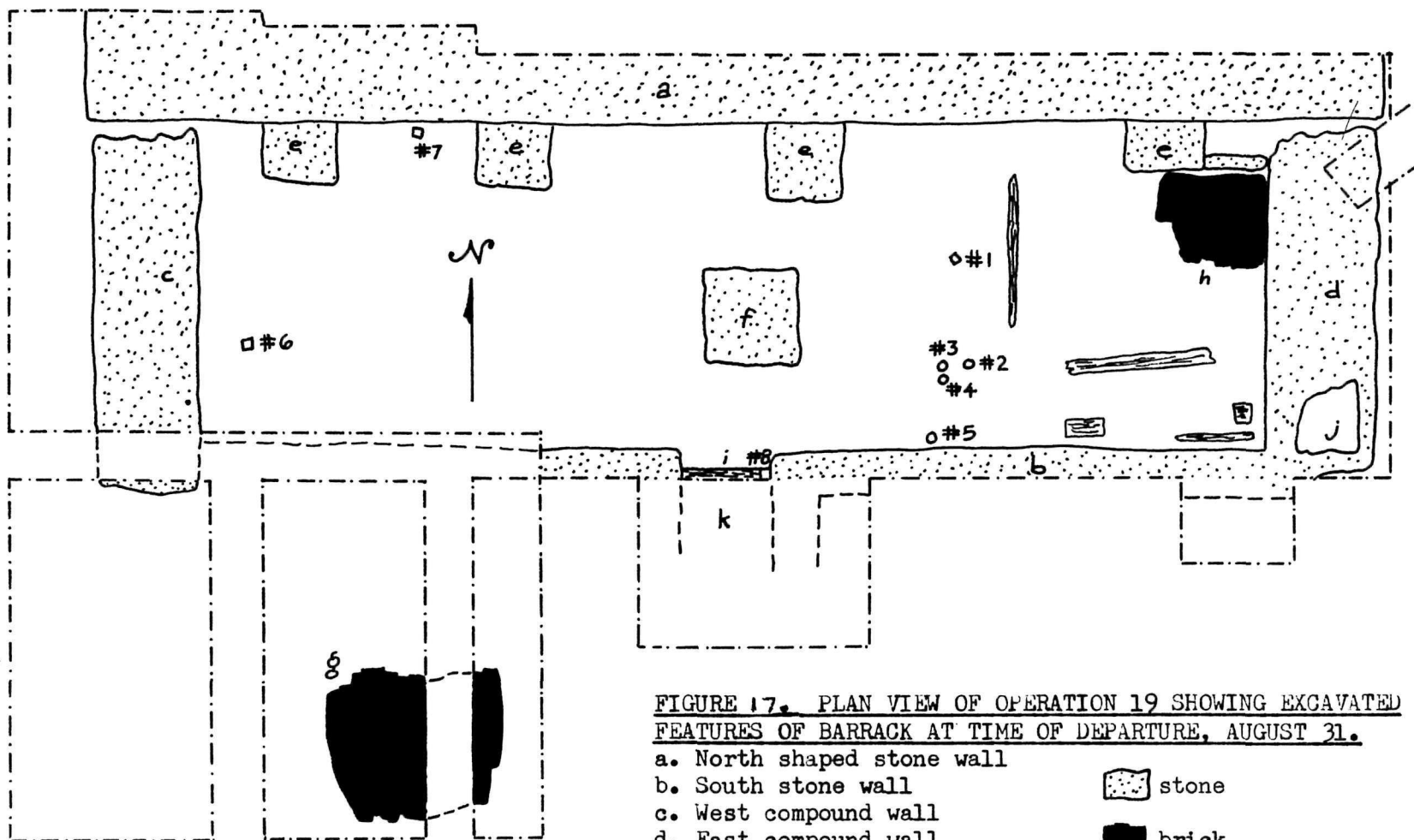



FIGURE 17. PLAN VIEW OF OPERATION 19 SHOWING EXCAVATED FEATURES OF BARRACK AT TIME OF DEPARTURE, AUGUST 31.

- a. North shaped stone wall
- b. South stone wall
- c. West compound wall
- d. East compound wall
- e. Counterfort
- f. Center stone feature
- g. Exterior brick feature
- h. Fireplace base
- i. Wooden door sill
- j. "incomplete" corner
- k. Entrance

 stone

 brick

 wood (posts are numbered)

- - - limit of excavation

- · - · - possible locations

SCALE: 1" = 10'

CHAPTER THREEDESCRIPTION OF THE STRATIGRAPHY OF OPERATION 2E19.

Most of the excavation occurred within the building limits. Consequently, not too much can be said about the exterior stratigraphy. In 19A, 19D, and 19E, an average depth of 1.1 feet B.S. was obtained. Only in 2E19K8 and in the western part of 2E19C was there any acceptable indication of exterior stratigraphy. Here, we reached depths of 3.19 feet B.S.

Considering the stratigraphy in cross-section, one can define two large groupings of layers on the basis of layer shape. Most of the layers are relatively flat or horizontal and do not have much slope to them. They form one group and their horizontal location corresponds to that of the building. The second grouping, restricted in location to on top of and just to the south of the North shaped stone wall, consisted of sloped stratigraphy. That is, not only do the northern and southern extremities of the layers greatly vary in elevation, but the layers are also roughly triangular in shape with the apex of the triangle pointing south. While the horizontal layers of group one run between the four building walls at a maximum elevation corresponding to the current level of the parade square, the triangular or wedge-shaped layers of group two are primarily located beside the N. shaped stone wall interior face and on top of the horizontal stratigraphy where the latter is also located beside that wall. It is my opinion that these two groups reflect two different kinds of deposition and this will be discussed in the chapter entitled "The interpretation of the stratigraphy and features of operation 19".

1. THE HORIZONTAL STRATIGRAPHY.

As has been said, the horizontal layers are located between the four

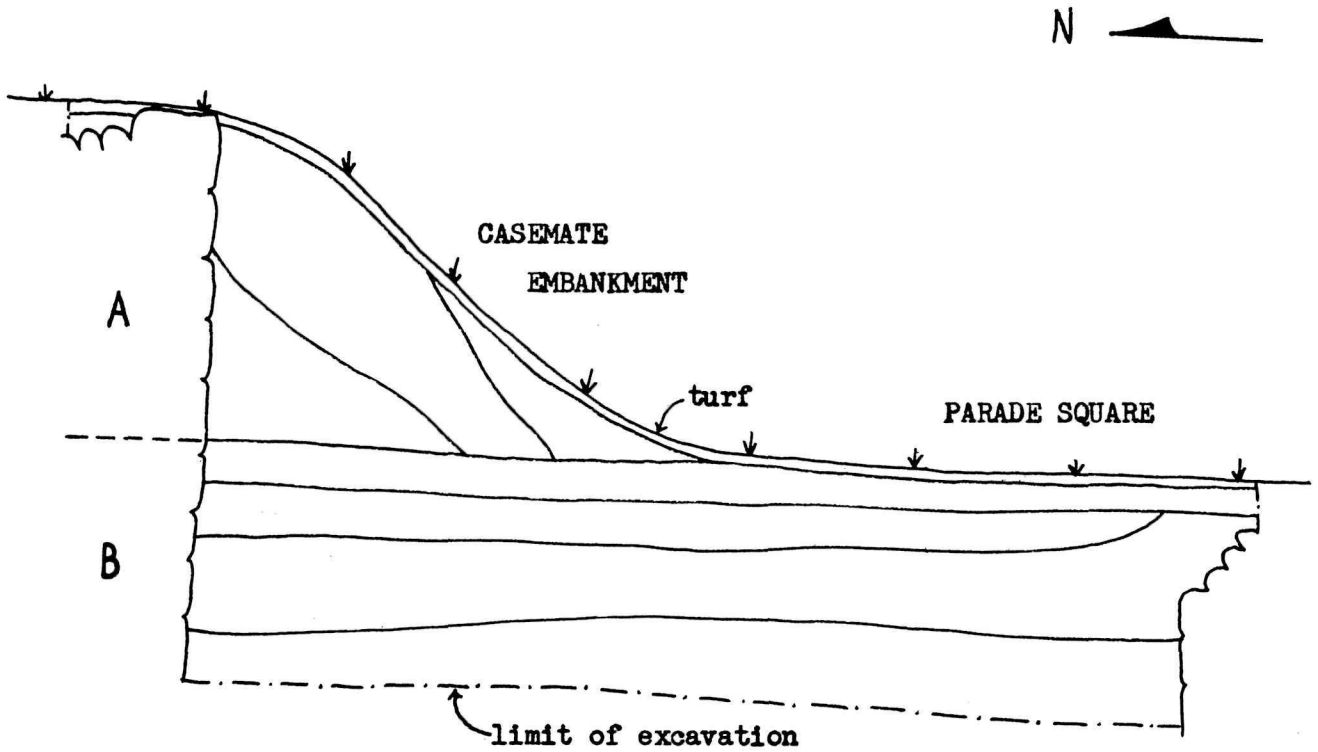

**FIGURE 18. IMAGINARY CROSS-SECTION THROUGH THE WIDTH OF OPERATION 2E19.**

Profile through operation 2E19, looking east, illustrating the spatial relations between the sloping stratigraphy(A) and the horizontal stratigraphy(B). The N. shaped stone wall is situated at the left, the S. stone wall at the right. Not to scale.



building walls. This does not mean, of course, that every individual layer has an horizontal extent equivalent to the dimensions of the building. Layers appear and disappear in various scattered locations; only the perimeter of horizontal stratigraphy corresponds to the interior of the building. (Horizontal stratigraphy also occurs outside the building but since this area does not fall within the limits of operation 19, except where it is related to wall structure, it will not be considered here). The vertical extent of the horizontal stratigraphy lies between the present surface of the parade square and the bottom limit of excavation.

Just because I used the term "horizontal", it must not be assumed that the layers are perfectly level and parallel and have an equal elevation reading along their entire extent. Rather, the layers display quite a bit of vertical as well as thickness variation, especially near features. But their basic orientation is towards the four cardinal directions and not up-down. This I believe to be a significant distinction and one which suggests a logical interpretation.

The vertical sequence of horizontal layers is not too complex. Except in 2E19N where there appears to be a noticeable disturbance of the stratigraphy, the horizontal layers can be divided into three--possibly four--significant units. This threefold division manifests itself not only in soil color but also in soil type and foreign (no-soil) deposition (stone, brick, wood, mortar). These units are not absolutes; minor deviations exist but they shall be classified with the units. Probably, the most effective method of defining these units is in the form of a summary for each unit.

(a) The first stratigraphic unit: it is located directly below the parade

square surface and on top of the second unit. Average thickness is 0.6 to 0.8 feet. Depth B.S. is equivalent to the thickness. Soil color is primarily a dark brown with Munsell readings varying from 7.5YR; 3/2 to 7.5 YR; 3/3 and to 10YR; 3/3. Some lenses of dark yellowish brown earth-- 10YR; 4/4--occur near the N. shaped stone wall. Soil consists of loam near the surface and a sandy-loam beneath the loam. Turf and top soil form part of this stratigraphic unit where present, the loam associated with the top soil. There is very little rubble; small brick and stone fragments are scattered throughout the layers with some larger stones near the N. shaped stone wall.

(b) The second stratigraphic unit: it is located directly beneath the first, consists of various shades of red soil from dark red to dark reddish-brown. Reddish-brown is the most common soil color while actual Munsell readings include 2.5YR; 3/6, 5 YR; 3/3, 5 YR; 3/4, and 5 YR; 4/4. Clay replaces the loam of the first unit as the dominant soil, with a sandy clay the most common. Thin layers of sandy loam are located at the bottom and at the top of this unit where the limits of the first and the second, and the second and the third stratigraphic units are poorly defined. Average thickness is between 1.5 to 2.0 feet, while depth B.S. varies from 0.6 to 0.8 feet to 2.2 to 2.5 feet. Rock rubble is scattered throughout this unit, with rubble concentrations near the bottom and near the N. shaped stone wall. A few bricks near the bottom of this unit.

(c) The third stratigraphic unit: it follows the second unit in the vertical sequence. Average thickness is 0.8 to 1.4 feet and average depth B.S. is from 2.5 to 3.0 feet to 3.5 to 4.0 feet. Soil colors are very

similar to the first unit, that is, a dark brown. Sandy loam is the dominant soil with scattered lenses of sandy clay near the top. This unit is characterized by foreign deposits--heavy concentrations of brick and mortar are common. The brick rubble consists of both fragmentary and whole bricks while the mortar occurred in two forms, mortar detritus and decomposed mortar. There were also occasional wooden fragments. These pieces, usually quite small, had a patternless provenience scattered throughout the layers.

The third unit generally extended to the bottom limit of excavation. In a few places, however, (such as in 2E19S1), different soil layers can be defined below those of the third. Whether these layers are part of a new fourth stratigraphic unit or whether they are merely anomalies of the third unit could not be determined. The soil colors are a mixture of dark browns and reddish browns which are often not readily distinguished. Sandy clay appears to be the dominant soil. The layer(s) are nearly void of rubble, the only exception being some small stone rubble near the N. shaped stone wall. This possible fourth unit differs most noticeably from the third unit in the absence of brick rubble and mortar deposits.

## 2. THE SLOPING STRATIGRAPHY.

Figure 18 illustrates the general shape and location of the sloping stratigraphy and also shows its relationship with the horizontal stratigraphy. The noticeable difference in elevation between the northern and southern extremities as well as the triangular shape of the layers are characteristic of the sloping stratigraphy. Along the interior face of the N. shaped stone wall a maximum thickness of 4.5 feet is valid for

the sloping layers. Its horizontal extent equals the length of operation 19 east-west and is between nine and ten feet north-south, measured from the N. shaped stone wall.

The sloping stratigraphy exhibits little variation in soil type (loam, clay, etc.) and soil color, while the occurrence of stone rubble is similar throughout the sloping layers. The soil is a dark brown loam or sandy-loam with Munsell readings of 7.5 YR; 3/3, 7.5 YR; 4/4, 7.5 YR; 4/2, and 10 YR; 3/3. Towards the south there are small lenses of very dark brown loam, 10 YR; 2/2, and dark yellowish-brown loam, 10 YR; 3/4. All the sloped layers have a high content of rock rubble, especially along the N. shaped stone wall. The rocks vary in size from small field stones to large shaped stones. High concentrations of mortar detritus occur in association with the N. shaped stone wall, located on top of the upper course, between the wall and the stone rubble, and along the south face of the wall. Like the stratigraphy, the mortar has a rough wedge shape with the apex pointing south. A few charcoal flecks and wood chips are scattered throughout these layers but they are not plentiful enough to form concentrations. With the exception of a brick concentration over counterfort #1, there were no brick rubble areas in these layers.

Except for the S.E. corner of 2E19N, the entire surface of operation 17 was covered with a thin layer of turf and top soil. Maximum turf thickness was approximately 0.25 feet while the top soil varied in thickness from several inches to 0.8 feet. The top soil was primarily a dark brown loam, 7.5 YR; 3/2, with little or no rubble.

Soil color was lighter outside the building than inside the building. While the exterior colors were generally a brown or dark brown,

the interior colors range from dark reddish-brown to dark brown to a dark yellowish-brown. Within the building walls there are dark and "greasy" soil probably attributable to refuse deposits. The very light brown colors are caused by the presence of mortar in the soil.

There were no stratigraphic indications of a footer trench for the building walls. Neither interior nor exterior profiles showed such anomalies as could be interpreted as being indicative of wall construction. Soil layers on both sides of the walls ran flush against the wall stones.

A lot-layer correlation table is presented in Table 2. We should note that the balks were the only areas dug stratigraphically with any consistency so that only there is there an absolute correlation between natural stratigraphic layers and excavation layers. We should also note, however, that the first lot of any sub-operation corresponded to the turf of that sub-operation and was usually no more than 0.25 feet thick. Generally, the top soil formed part, if not all, of the second lot.

The above was a general description of the operation 2E19 stratigraphy but a detailed description of each layer is needed for the lot-layer (Table 2):

Layer 1--turf and top soil of operation 19 located on top of the sloping and horizontal stratigraphy; dark brown loam, 7.5 YR; 3/2, with very little scattered stone and fragmentary brick rubble.

Layer 2--ill-defined layer of dark and very dark brown sandy loam, 7.5 YR; 3/3 and 10 YR; 4/4, located directly beneath the turf and top soil. Layer 2 is part of horizontal and sloping stratigraphy, widening when near the N. shaped stone wall. Heavy concentrations of decomposed mortar and stone rubble along the

N. shaped stone wall; scattered brick rubble, especially near the E. compound wall.

Layer 3--reddish-brown sandy clay, 5 YR; 3/4 and 5 YR; 3/2, located beneath layer 2. Light concentrations of brick and field stones are scattered throughout the layer. The layer does not fully extend to the N. shaped stone and the E. compound walls; here layer 2 increases in thickness and layer 4 rises somewhat to replace this layer.

Layer 4--thick layer of dark brown sandy clay, 7.5 YR; 3/2 and dark yellowish-brown sandy clay, 10 YR; 3/4, containing high concentrations of decomposed mortar and brick rubble. Scattered pieces of wood and stone rubble; in many areas this layer is located at the bottom limit of excavation.

Layer 5--dark reddish-brown sandy clay, 5 YR; 3/4 and 7.5 YR; 4/4, containing little decomposed mortar and rubble. It only appears in those trenches where layer 4 does not extend to the bottom of excavation and is widest along the N. shaped stone and E. compound walls.

Layer 6--layer with a high content of decomposed mortar and brick rubble, yellow-brown sandy clay, 10 YR; 5/4. A very thin deposit (0.2 feet) in 2E19S1 under layer 5 and a much thicker occurrence (1.5 feet maximum) in 2E19N under layers 5 and 11.

Layer 7--a thin layer of dark reddish-brown clay, 5 YR; 2/2, visible only in 2E19M and 2E19P. It contains little or no rubble and is located under layer 6 where it is present, otherwise it is underneath layer 5.

Layer 8--thin layer of red brown loam, 5 YR; 4/4, found at the surface of 2E19N and 2E19P where the turf is absent. It represents the fill put into a shallow depression which was dug in the summer of 1966 for the backdirt railway track.

Layer 9--another thin layer, located only in 2E19P underneath layer 8 and on top of layer 2 which dips down in this sub-op. Soil is a dark reddish-brown loam, 5 YR; 2/2, with scattered decomposed mortar along the E. compound wall. Little or no rubble is present.

Layer 10--about 1.0 feet thick, located along the N. shaped stone wall and extending southward to the southern face of the northern trenches. Soil is a dark yellowish-brown loam, 10 YR; 3/4, similar to layer 4 but without any decomposed mortar. In 2E17J it is situated between layers 3 and 4; in 2E19N it is between layers 2 and 11.

Layer 11--a lense of dark reddish brown sandy loam, 5 YR; 3/4, located underneath layer 10 and on top of layer 6 in 2E19N. It is about 1.0 feet thick and 2.2 feet east-west, and along the interior face of the E. compound wall.

CHAPTER FOURDESCRIPTION OF FEATURES IN OPERATION 2E19.

Most of the descriptive data will be concerned with the eastern half of operation 19--the area for which I was responsible. Some general comments will be made about the western half of the building but this paper should not be considered the ultimate source of descriptive information for this area.

1. WALLS.

Four stone walls, each representing one side of the building, were uncovered. They were named the North shaped stone wall, the South stone wall, the East compound wall, and the West compound wall. The western half of the S. stone wall as well as the southern end of the W. compound wall still needed to be exposed at the time I left the excavation but their approximate location could be determined from the location of the other walls. The exterior dimensions of the building, based on wall measurements, were 79.1 feet east-west and approximately 24.0 feet north-south (measured to the back of the top stones of the N. shaped stone wall). Although the top of the footer course of the N. shaped stone wall was uncovered, nowhere was the entire height of the walls exposed.

(a) South stone wall: approximately 51.1 feet of the total length of this wall has been uncovered. The equivalent interior dimension is 44.4 feet. A gap in the S. stone wall, 5.8 feet long and with the width of the wall, is located 29.7 feet west of the interior S.E. building corner. The S. stone wall to the east of this gap is comprised of relatively small unworked field stones. The interior face was not shaped but it is possible that some of the field stones were slightly worked to ensure a vertical



interior face. The exterior face of the east half of the S. stone wall was on visible in the unfinished extensions to 2E19K (2E19K7-8) and 2E19P (2E19P6-7). No shaped stone face was apparent there.

The western part of the S. stone wall, 8.9 feet long and located west of the large gap, consists of worked stones usually larger than those used in the eastern part of the wall. The stones are roughly rectangular in shape with an average size of 1.0 by 1.5 feet. What appears to be a shaped stone forms the eastern edge of the second course of the west S. stone wall.

Because the extensions to 2E19K and 2E19P were not finished, the only indications of wall thickness that we have is the distance which the interior face of the S. stone wall projects northward from the S. trench face. At the western end of the wall this measurement is 1.9 feet while at the interior S.E. corner it is 1.45 feet. Maximum thickness is 2.0 feet and the minimum is 1.4 feet.

Elevations on top of the S. stone wall vary from 122.6 feet A.S.L. in the west to 124.8 feet A.S.L. at the interior S.E. corner. Maximum elevation reading was 124.8 feet A.S.L. while the minimum reading was 122.5 feet A.S.L. (east 19G). The wall height varied from 1.6 feet in the west to 4.5 feet in the east. Maximum height is 4.5 feet and the minimum height is 1.5 feet. The west S. stone wall consists of three courses while the course total for the east S. stone wall varies from five to eight. Some of the courses do not continue for the entire length of the east S. stone wall while new courses begin in various places.

The readings indicate that, although the S. stone wall may be a straight wall, the interior face is not perfectly straight but, rather,

has a slight curvature to it, especially noticeable in the east end (fig. 17). This may be due to the fact that this wall is thinner than any of the other walls and that the weight of the building caused this curvature. The absence of a shaped stone interior face which might have offered support would increase this possibility.

The 5.8 feet gap will be discussed under heading number 5, entitled "entrance".

(b) North shaped stone wall: it is 79.7 feet long and is located approximately twenty feet to the north of the S. stone wall. This impressive wall, the longest and the highest in operation 19, consists of an interior face of shaped stone backed with a stone rubble core. The shaped stones are of various sizes but the majority of them are quite large, some being 2.5 feet long and one foot wide. Four bonded counterforts help support this massive wall; they will be discussed under heading number 2 entitled "counterforts".



Fig. 19. Photograph of the North shaped stone wall, looking north. Note the four stone counterforts along south face of wall.

A maximum of ten courses, including the footer course, were uncovered. Many of the upper course stones are missing due to wall collapse resulting in the discontinuation of the upper courses in several places. In 2E19J, ten courses remain while in 2E19N only eight courses are still standing. Usually one stone constitutes the thickness of a course but in several places two small shaped stones replaced one larger one. In these cases, I considered the two smaller stones as forming one course (called a level course).

The rubble core located behind the interior face extends as much as two feet above the top of the shaped face. Height measurements and elevation readings vary greatly for the interior face because no single course covers the entire top of the wall to form a regular surface. The tenth course, which is the top course in 2E19H, 2E19J, and 2E19M, has an average elevation of 130.0 feet A.S.L. The eighth course, the highest in 2E19N, has an elevation of 128.2 feet A.S.L.

Only the top of the interior face footer course has been uncovered. Elevations on this footer course range from 121.1 to 121.8 feet A.S.L. The height of the wall (excluding the rubble core) varies too, depending on the total number of courses, from a maximum of 8.8 feet to a minimum of 6.4 feet in 2E19N (west half measurements not included).

The footer course consists of a row of shaped stone jutting out (south) from underneath the second course of the interior face. This jutting or projecting ranges from 0.5 feet maximum to a non-visible minimum where the footer course does not appear to project southward at all (e.g., last 2E17J). Generally, however, a definite footer course can be defined.

A profile through the N. shaped stone wall would reveal an overhang

(sometimes over one foot) by the top of this wall. Even with the four supporting counterforts, the wall yielded to some of the same pressures which dislodged many of the face stones, resulting in a noticeable wall slant. For example, the tenth course of the interior face in 2E19H overhangs the first course by 0.6 feet, although the difference between the ninth and tenth courses are not easily visible.

An interesting similarity exists between the west and east top corner stone of the N. shaped stone wall. Not only are both stones shaped and have a noticeable 90-degree corner angle, but both are tremendously large—by far the two largest stones uncovered in operation 19. The east corner stone is 1.4 feet thick, 2.2 feet wide, and at least 3.6 feet long (the full N-S extent of this stone is not uncovered).

The N. shaped stone wall also served as the retaining wall for Loudoun's battery. It stabilized the earth of the battery even though that earth presented tremendous pressure against the wall. Within the battery is located the British stone and brick casemate. It is situated primarily in the eastern half of the battery although it may have originally extended further westward. The south wall of the casemate is located near the interior face of the N. shaped stone wall and this wall undoubtedly helped to stabilize and strengthen the casemate. Many of the bricks uncovered on top of the eastern half of the N. shaped stone wall are probably related to the original casemate structure.

(c) West compound wall: because three feet of the southern part of this wall still needs to be uncovered and because Miss Herst was responsible for this half of the building, I will not say too much about this wall.

The wall consists of an interior and an exterior face of field stones

with a stone rubble core in between. Wall width is approximately 7.2 feet and length is 24.0 feet. The face stones have an average size of 1.0 feet by 0.7 feet and somewhat resemble those of the east S. stone wall. Seven courses of the interior face have been exposed as well as the top of an eighth.

A narrow gap, about one foot wide, is situated between the northern end of the W. compound wall and the N. shaped stone wall. That is, the W. compound wall does not fully extend to the N. stone wall.

The northern quarter of the interior face is not complete. Several of the face stones are missing, leaving a step-like pattern with the eighth course projecting the furthest northward. The gap between the N. shaped stone wall and the eighth course of the interior face is only 0.4 feet.

(d) East compound wall: this wall, like the W. compound wall, is constructed of two vertical stone faces with a rubble fill in between. While the exterior face consists of unworked field stones, the interior face was built of rough shaped stones. The wall is 18.9 feet long along the interior; the equivalent exterior measurement is 20.9 feet. Wall width varies slightly from 6.75 feet in the south to 6.6 feet in the north.

The wall exterior was never fully dug to its base; the interior was excavated to the bottom course. Enough was exposed to define the feature but no total excavations were undertaken. Along the exterior face only the top course--approximately 0.5 feet--was uncovered (except where 2E13F10 and 2E13F11 are located next to the wall; there 2.15 feet of the total height was revealed). Nine courses of the interior face could be counted but there was no indication of a footer course. Wall height at the

interior S.E. building corner is 5.4 feet while at the northern end of the interior face it is 4.8 feet.

The majority of the stones of the interior face are missing in a situation similar to the interior face of the W. compound wall. The second course from the bottom (eighth course from the top) is the first complete course without any removed stones. Nearly all of the stones from the above seven courses were gone. A "step-like" pattern again resulted, this time in the southern end of the interior face near the interior S.E. building corner. The lowest or first course was only exposed in 2E19S1 so we cannot say whether or not that course covered the entire length of the wall. I do think, however, since the course immediately above was intact, that we can assume that the first course is complete.

A narrow gap, similar to the one located between the W. compound wall and the N. shaped stone wall, is situated between the northern end of the E. compound wall and the interior face of the N. shaped stone wall. Its average width is 1.3 feet while its length corresponds to the width of the E. compound wall.

What appears to be an incomplete corner occurs where the S. stone wall meets the exterior face of the E. compound wall. Here, the compound wall has no rubble core. Not only are the exterior and interior faces of the E. compound wall well defined, but the interior face of the S. stone wall can also be seen. This face is usually, of course, hidden by the rubble core. But what is of added interest and that which prompts me to call this corner an incomplete one is that both the interior face of the S. stone wall and the exterior face of the E. compound wall are only one course wide and one course high. All indications are that there are no further courses located at a lower level.

Along the exterior face (E. compound wall) this condition occurs for 4.8 feet, from the southern edge of the rubble core to the S. stone wall; along the interior face (S. stone wall) the length is 3.6 feet from the interior edge of the exterior face to the interior edge of the interior face of the E. compound wall.

The interior S.E. building corner, that is, the corner formed by the meeting of the interior faces of the S. stone wall and the E. compound wall, is a bonded corner. Courses 1, 2, 3, 4, 6, and 9 of the E. compound wall interior face are bonded with the respective courses of the S. stone wall interior face. Actually, the S. stone wall has no ninth course but the ninth course of the E. compound wall does extend onto the top of the eighth course (S. stone wall), giving the appearance of intended bonding even though there is no actual physical bonding. The second course of the E. compound wall consists of two small shaped stones placed on top of one another where this course meets the S. stone wall. The bottom stone bonds with the second course of the S. stone wall while the upper stone abuts part of the third course. The other courses--the fifth, seventh and eighth--abut each other.

A small "wall", or rather, a series of stones, runs E-W connecting the S.E. corner of counterfort #4 with the second course of the E. compound wall interior face. About 3.9 feet long, it is one course wide and two courses high. The second (upper) course consists of only one stone which is bonded with the second course of counterfort #4.

Although the interior length for this wall was given at 18.9 feet, the interior face is only 16.8 feet long. The interior face stops 2.1 feet south of the northern edge of the wall. At this point, the above

described small "wall" connects the S.E. corner of counterfort #4 with the northern edge of the interior face.

## 2. COUNTERFORTS.

Along the N. shaped stone wall, bonded with the interior face, are four stone counterforts. They are four distinct features numbered one to four from west to east (Fig. 17).

Using center measurements, counterfort #1 is located 12.8 feet east of the western corner of the N. shaped stone wall, counterfort #2 is 25.8 feet east of the same point, counterfort #3 is 43.8 feet east, and counterfort #4 is 65.65 feet east. Using edge measurements, the gap between counterfort #1 and #2 is 8.4 feet, between #2 and #3 is 13.2 feet, and between #3 and #4 is 17.2 feet. Both end counterforts (#1 in the west and #4 in the east) are located 10.5 feet from their respective N. shaped stone wall corners.

Although the measurements vary within a limited range, the counterforts are basically square along the horizontal plane. The length, thickness, and width dimensions given below are maximum dimensions but actual readings vary from course to course. Since average measurements do not present the full scope or total extent of the features, maximum dimensions will be given instead.

In an east-west direction, counterfort #1 and #2 measure 4.6 feet, counterfort #3 is 5.0 feet, and #4 is 5.3 feet. Along the north-south axis the measurements vary along the east and west face of each counterfort. Counterfort #1 is 3.2 feet N-S along the W. face and 3.8 feet along the E. face; #2 measures 3.7 feet(W) and 4.0 feet(E); #3 is 5.1



feet (W) and 4.5 feet (E) and #4 is 3.5 feet (W) and 3.3 feet (E). No counterforts were, therefore, perfectly square, each feature being somewhat longer E-W than N-S. Counterfort #3 is the largest, #1 the smallest.



Fig. 20. Photograph of counterfort # 3, looking E .

2E - 760 X

The entire vertical extent of the counterforts was never exposed. These features were dug as part of the N. shaped stone wall and as such the bottom limit of excavation was identical for both.

Counterfort #3 is 5.8 feet high (W) and 6.7 feet high (E). It is constructed of seven courses along the W. face and 8 courses along the E. face. The first footer course of both faces correspond in vertical location to the footer course of the N. shaped stone wall. Along the W. face, courses 3, 6, and 7 bonded with the N. shaped stone wall interior face, courses 3, 6, and 7 respectively. Along the E. face, courses 1, 4, and 8 of the counterfort and the N. shaped stone wall are bonded. The others abut.<sup>t</sup>

Counterfort # 4 is 4.95 feet high (W) and 5.4 feet high (E). Both faces consist of seven courses, with courses 1, 2, 4, 6, and 7, bonded with the respective courses of the N. shaped stone wall. The others abutt.

For a detailed description of counterforts # 1 and # 2 refer to Miss Herst's report on the excavation of operation 2E19. Counterfort # 1 consists of nine courses while # 2 has a total of eight courses.

### 3. FIREPLACES.

One fireplace base was uncovered in operation 19. It is located in the NE building corner, interior and adjoining to the S. face of counterfort # 4 and the interior face of the E. compound wall. Roughly rectangular in shape, it measures 5.7 feet N-S along its E. edge and 6.65 feet E-W along its N. edge. Only in the SW corner, where the edge becomes more irregular, is the rectangular shape lost. There is a slight E-W along to the brick base, the eastern end being somewhat higher. Average elevation for the western end is 121.35 feet A.S.L. and for the eastern end it is 121.7 feet A.S.L.

There are two small brick concentrations associated with the brick base (Fig. 21). The first, located in the NE corner of the base, consists of primarily whole bricks, all of which were darkened due to burning. A small piece of wood was found among the bricks while wood ash covered the entire concentration and also filled the spaces between the bricks.

The second concentration, located in the SE corner of the base, not only covered part of the brick base but also covered part of the top course (the second) of the E. compound wall interior face. The bricks, either whole or brick bats, had not been burned. No wood or wood ash was

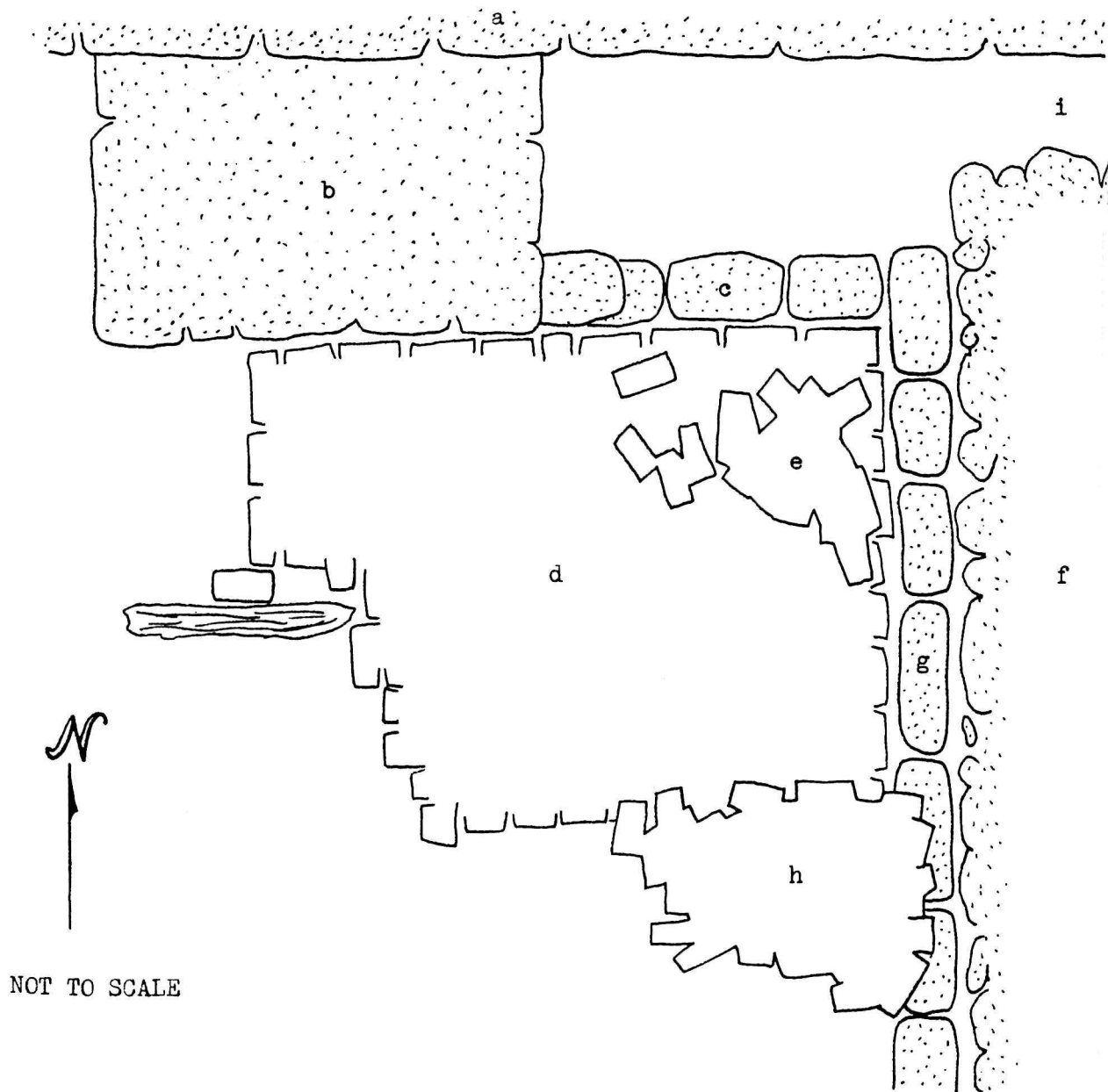

NOT TO SCALE

FIGURE 21. PLAN VIEW OF FIREPLACE BASE.

- a. North Shaped Stone wall.
- b. Counterfort # 4.
- c. Small wall connecting counterfort # 4 with E. compound wall.
- d. Fireplace platform or base.
- e. Small brick concentration with burned bricks.
- f. East compound wall rubble center.
- g. East compound wall interior face, second course.
- h. Large brick concentration, unburned bricks.
- i. Small gap between E. compound wall and N. shaped stone wall.

directly associated with the concentration although there was a noticeable deposition of wood ash in the soil two or three inches above the bricks. Decomposed mortar was found between the bricks.

In the western half of the building, over counterfort #1, a large concentration of brick was uncovered. These were primarily whole bricks and they could have been part of a fireplace-chimney structure. This possibility is further supported by the presence of a chimney stone in direct association with the bricks. No measurements are available to me but the stone was nearly square. It also had a large tapered hole with a diameter equivalent to about  $2/3$  the width of the stone.

#### 4. CENTER STONE FEATURE.

Located in the approximate center of the main trench of 2E19 is a feature of unworked field stones. Unnamed because of lack of evidence for its function, it will be referred to as the center stone feature (Fig. 17). Nearly square along the horizontal plane, it measures 6.5 feet E-W and 6.1 feet N-S. Its northern face is 8.6 feet south of the N. shaped stone wall, its eastern face is 29.3 feet west of the E. compound wall.

Three full courses and the top of a fourth were uncovered. On top of the feature there are several field stones; this stone rubble, a maximum of 0.9 feet thick, does not form a course but it is part of the feature. The center stone feature has a maximum height of 2.9 feet, including rubble, and 2.2 feet without the rubble. Average height with rubble is 2.5 feet, without rubble is 1.9 feet. Elevation A.S.L. for the top of the fourth (top) course ranges from 123.0 to 123.5 feet; elevation for the bottom limit of excavation and, subsequently, the bottom of the feature, varies from 125.1 to 125.7 feet A.S.L.

The stone used in the center stone feature is unworked field stone. The size of stones ranges from 1.6 by 1.2 feet to 0.7 by 0.6 feet. The average size is 1.0 feet long and 0.8 feet wide. Stone thickness fluctuates slightly between 0.5 and 0.7 feet.

#### 5. ENTRANCE.

The southern extension to 2E19K revealed the top of a stone wall running N-S and joining the S. stone wall at the eastern end of the 5.8 foot-long gap (Fig. 17). The wall was constructed of unworked field stones and was 6.1 feet long. Only 0.6 feet of its total thickness was showing, the remaining stone being covered by the earth of 2E19V. Average elevation for the top of the wall was 124.7 feet A.S.L. Excavations were still going in 2E19K8 and had just been started in 2E19V when I left for Vancouver. A 3.1 foot high wall had been uncovered at this time. The exact horizontal location of the wall had not, however, been established. That was the reason for using a dashed line rather than a solid one to locate this feature on Figure 17.

The 5.8 feet wide gap, mentioned above and briefly described under the heading "S. stone wall", contains a wooden door sill running E-W. The sill is 0.4 feet thick and at an elevation of 121.15 feet A.S.L. Only 0.75 feet of its total width has been exposed, the remainder still covered with the earth of 2E19V.

The remains of a wooden post are located at the eastern extremity of the sill alongside the W. end of the east S. stone wall. The post measures 0.8 feet N-S and 0.6 feet E-W, the N. edge of the post being flush with the N. edge of the sill. The post is 0.35 feet high. At the opposite end of

the sill there is a notch, 0.5 feet long (E-W), 0.18 feet wide, and 0.4 feet deep. Its western edge is flush with the W. end of the sill and the E. end of the west S. stone wall. The notch is 0.15 feet south of the N. edge of the sill. A similar notch may be located underneath the post at the E. end.

#### 6. WOODEN REMAINS.

No intact wooden cellar floor had been uncovered at the time of my departure. Near the bottom limit of excavation numerous pieces of wood were found. They varied greatly in size, shape, and state of preservation. Some pieces had square nails while some just had nail holes; most had neither. Their location was not restricted to any one area although there was somewhat of a concentration near the SE building corner. No real pattern to their placement was noticeable. These wooden remains consisted of eight uprights plus a variety of horizontal remains—plank fragments, small boards, scraps of wood, etc. Several of the larger pieces will be discussed; for a general picture of the wooden remains refer to field drawings 67-5-34a, b as well as Fig. 17.

A long narrow timber running N-S was uncovered in the E. half of the operation (2E19M6). The timber is roughly round with the northern end sharpened into a point while the southern end was not sharpened. It is in a good state of preservation except for the southern end which is quite rotten. It is 9.9 feet long (N-S), the tapered point at the N. end being 0.5 feet long. Average width is 0.4 feet while the elevation A.S.L. varies from 121.29 feet in the N. to 121.44 feet at the S. end. This timber may have been a sleeper beam for the cellar floor but there is no

evidence for either nails or nail holes in the wood, something which probably would have been present if this timber had functioned as a sleeper beam.

The second major piece of wood consisted of a 0.13 feet thick plank about 10.0 feet long and averaging 1.0 feet wide. It was located in the SE building corner and has a general E-W orientation. No nails or nail holes were present but this wood may be the remains of the cellar Floor. Two smaller pieces of plank were also uncovered in the same area. One measured approximately 0.14 feet thick, 1.2 feet wide, and 1.8 feet long and had an elevation of 121.0 feet A.S.L. It was located near the S. interior face of the E. compound wall. The second piece, located near the interior face of the S. stone wall, measured 0.13 feet thick, 1.0 feet wide, and about 2.7 feet long.

The remains of eight vertical uprights—or parts thereof—were uncovered. Half were round or oval shaped while the others were square or rectangular. One rectangular post, the one associated with the wooden sill, has already been described in the discussion of the entrance. The posts were assigned numbers one to seven for ease of reference.

Post #1 is located in the eastern part of the building, in the SE corner of 2E19J. The upright is rectangular, 0.4 by 0.3 feet, and projects 0.3 feet above the trench floor (the trench floor is 2E19J6; 2E19T has not been excavated yet).

Post #2 is one of four clustered circular-oval uprights located to the south of post #1. Hidden by a notched timber which lies on top of it, the post has a diameter of 0.2 feet and is 0.3 feet high. It is circular, very rotten, and slopes towards the north, that is, the top is farther

north than the bottom.

Post #3 is 1.38 feet directly to the west of post #2. It is 5.08 feet north of the S. stone wall, 10.2 feet east of the E. end of the wooden sill (all measurements are center measurements). Its oval shaped with an average diameter of 0.35 feet, 0.5 feet high and also sloping northward, and is in a fairly good state of preservation.

Post #4 is located 0.43 feet to the south of post #3. It is circular like upright #2 with a diameter of 0.2 feet, 0.4 feet high and sloping northward, and is in a very poor state of preservation.

Post #5, the last of the four clustered circular-oval uprights, is located 0.42 feet north of the S. stone wall and 10.05 feet east of the E. edge of the wooden sill. It slopes to the north. Diameter is 0.32 feet while height is 0.43 feet.

Uprights #6 and #7 are located in the western half of the building. Number six has the same horizontal dimensions as #1--0.4 by 0.3 feet-- and is 0.3 feet high. Its exact position is 5.5 feet north of the S. face of trench 19F and 3.0 feet east of the interior face of the W. compound wall.

And finally, post #7 is located along the S. face of the N. shaped stone wall, 13.2 feet east of the W. compound wall interior face. It is the only one square post--0.4 feet square. No height was measureable because the top of the upright was flush with the trench floor.

## 7. EXTERIOR BRICK FEATURE.

In 2E19A and 2E19E, exterior to the building, was uncovered a horizontal brick feature (Fig. 17). The northern extremity of the feature is 10.5



feet south of the N. face of trench 2E19E while its western extremity is 6.4 feet west of the E. trench face. Although not square, the horizontal dimensions are 8.1 feet N-S and 6.3 feet E-W (maximum) in 2E19E. In 2E19A located 3.0 feet to the east of 2E19E, the same feature occurs along the W. face of the trench. There the N-S measurement is 7.9 feet while the E-W maximum is 1.9 feet. The feature lies at an average depth of 0.4 to 0.5 feet B.S. or at an average elevation of 124.4 to 124.5 feet A.S.L.

The red bricks lie flat, the only exception being the bricks which comprise the western edge of the feature. They are on their ends at an angle of approximately 135 degrees away from the horizontal plane and pointing towards the west. Towards the north this edge is not well defined. The bricks used are either whole bricks or brick bats and lie in an inverted gamma pattern ( $\Gamma$ ).

CHAPTER FIVETHE INTERPRETATION OF THE STRATIGRAPHY AND FEATURES  
OF OPERATION 2E19.1. HISTORICAL INTERPRETATION.

The British captured Fort Beausejour on 16 June, 1755 and renamed it Fort Cumberland. The French entrance between Prince Edward and Prince Henry bastions was closed with an earth curtain wall containing a stone and brick casemate (Fig. 1). By 1761 a gun battery of earth, wood, and stone (labelled 'i' on Fig. 1) had been built on top of this curtain wall. Called Loudoun's battery, it was first indicated and described on a British fort plan, undated but drawn between 1757 and 1761: "Loudoun's Battery a Curtain levell'd & rebuilt by the English on w<sup>ch</sup> is mounted 4 twelvepounders" (Nadon 1966: appendix 6, map No. H.M. 15414). In 1776 Jonathan Eddy, a sympathizer with the revolt of the American colonies, besieged Fort Cumberland in an attempt to dislodge the British from the Chignecto area. Although unsuccessful in his venture, Eddy did cause the demolition of the buildings inside the Fort to prevent fires from exploding mortar shells. It is around this time that the barrack excavated in operation 2E19 is first mentioned in the historical record.

In 1776 the buildings inside the Fort were torn down and new buildings were erected later that year on the same sites as the old ones (Nadon 1966: 2: L: 6). On a profile through Loudoun's battery called "Section--Mantresor's Temporary Project", and dated 1776 (presumably a reconstruction project after the siege), there is no indication of a building just to the south of the curtain wall although the parade square surface is shown. On the first plan after the siege, dated 1779, a large rectangular building

is located 7.5 feet to the south of the stone retaining wall of Loudoun's battery (assuming that the plan scale is accurate). The building is labeled as an officers' quarters and this is the first time that a building has been definitely located on the site of operation 19. In his historical report, Nadon labels this building 5H and I use this abbreviation for ease of reference.

Building 5H was constructed, therefore, between 1776 and 1779. It was never mentioned on plans, descriptions, etc. prior to the siege of 1776 but it can be definitely identified on the plan of 1779. It appears likely that 5H was built at the same time the British were engaged in rebuilding the old buildings which they had torn down during the siege.

The plan of 1784 also shows 5H but the gap between the barrack and the stone retaining wall is 9.0 feet rather than the 7.5 feet of the 1779 plan. In 1793 the garrison was withdrawn from the Fort but it returned in 1809 in anticipation of the War of 1812. In 1803, however, a traveller named Gray had made a sketch of the Fort which showed all the buildings inside the Fort still standing. Included on Gray's sketch was a 1-chimney, 2-storey structure which might have been the officers' barrack (5H).

The date 1823 is the first of three possible dates for the destruction of 5H. A written description of the buildings at that time mentioned two 2-storey buildings with cellars and one 1-storey building that were vacant. The location of these structures, however, was expressed in terms of their spatial relationship to a "bomb-proof" shelter whose location was not stated. Depending on which casemate was "bomb-proof", 5H may or may not have been standing in 1823. If reference was being made to the casemate underneath Loudoun's battery, then there was no 5H; if one of several

other casementes was the "bomb-proof", then 5H was still standing.

In 1844 two of the three buildings were moved onto the parade square but it wasn't until 1853 that these activities were documented. One of the two buildings was a 2-story officers' quarters.

The 1853 report on Fort Cumberland mentions the existence of three buildings, including a wagon shed on the east end of 2E19. There definitely was no officers' barrack anymore at this location. Several possibilities emerge as to what happened to 5H between 1844 and 1853. First of all, 5H may have been moved and standing elsewhere, probably in the center of the parade square. Secondly, it was torn down before or in 1844. And finally, that 5H remained in its original location until some time between 1844 and 1853 when it was torn down and replaced with a wagon shed. Because the year 1844 was one of much constructive activity, it is likely that the erection of the shed occurred at the time. This would place the date of destruction or movement of 5H at 1844 or prior to it but probably not as early as 1823. There is, however, no overwhelming evidence to substantiate any of the alternative explanation and dates.

## 2. STRATIGRAPHIC INTERPRETATION.

The chronological sequence of soil layers is governed by the principle of super-position: the lower layer, the older it is. It follows that a stratigraphic layer is younger than the layer below it and older than the layer above it. Except under conditions of stratigraphic disturbance, this principle is valid. So it is for operation.19. The fact that a short duration of time is involved does not invalidate the principle.

I have already suggested that parts--or possibly all-- of the cellar depression left by the officers' quarter was intentionally filled to parade square level to permit the construction of the wagon shed in the southeast corner. This is also suggested by the horizontal stratigraphy within the four building walls. The layers are not explainable in terms of natural forces. Indistinguishable stones and brick rubble is scattered throughout the entire vertical sequence (though not too common in the upper layers) while decomposed mortar layers stop abruptly at stone features rather than displaying the customary leaching pattern in which the mortar slopes down concavely from the origin leaching. These stratigraphic facts seem to substantiate the possibility that the barrack cellar was intentionally filled. The material used for fill probably came from within the fort and was likely a mixture of building rubble and earth. The earth may have come from cellars and foundations being dug for a new or moved building while the structural rubble--stones, whole bricks, brick fragments, and pieces of wood--could have originated from buildings being torn down or moved. If the officers' quarter wasn't moved, its waste may have been used to fill its own cellar.

I have suggested that the horizontal stratigraphy was the result of intentional fill. The sloped stratigraphy, however, appears to have been caused by natural forces. The collapse of the upper courses of the N. shaped stone wall and the subsequent soil creep has resulted in wedge-shaped layers with the apex pointing south. The presence of stone rubble, especially shaped stones similar to those used in the wall, as well as the absence or incompleteness of most of the upper wall courses supports this interpretation. And the fact that the horizontal location of the sloped

stratigraphy is restricted to that area adjacent to the N. shaped stone wall seems to confirm my interpretation. The proximity of the two establishes an undeniable association.

We should now examine the various types of stratigraphic layers and the meaning in terms of an overall interpretation. The layers will not be discussed individually; rather, they will be dealt with in groupings of similar strata.

The turf and top soil forms one of the most obvious stratigraphic groupings and was described as part of unit one of the horizontal stratigraphy. The location or spatial distribution of the turf and top soil has already been discussed.

The deposition of the present turf and top soil is logically of recent origin for two conditions had to be met prior to their formation: (1) the earth underneath the turf-top soil had to be at a level corresponding to the current level of the parade square; (2) no structure could be located on the site since this would prevent the formation and growth of turf. Only when the cellar depression had been filled to a level roughly corresponding to the current parade square level, and only when the officers' quarter and the smaller wagon shed had been removed, could the turf have started to form. The location of the turf on top of the sloping stratigraphy demands that the turf and its associated top soil be dated after the partial collapse of the N. shaped stone wall and soil creep of the casemate embankment. This places the earliest date for the beginning of the present turf in the late 1850's. This does not mean that there were no turf layers prior to the present one; they would now be, however, part of the underlying earth.

The mortar layers of operation 19 form a conspicuous group. They

comprise much of the third unit of the horizontal stratigraphy while mortar is also present in the sloping stratigraphy. Its greyish-white color and association with brick rubble makes it stand out among the other layers.

The mortar of the sloping layers is scattered throughout the layers but is concentrated near the top of the N. shaped stone wall. This mortar detritus also forms a wedge shape with the apex pointing south. The location and shape of the mortar as well as its association with the stone rubble indicates a leaching from the N. shaped stone wall. The mortar was originally between the shaped stones of the wall but with the collapse of some of the upper stone courses, the loosened mortar leached southward along with the soil creep. The mortar detritus is an integral part of the sloping layers and it is very unlikely that the mortar had origins different from that of the soil.

The mortar of the horizontal stratigraphy appears to have been deposited in a different manner. I have already suggested that the horizontal layers were the result of intentional fill. The form or shape of the mortar layers is, in my opinion, strongly indicative of that interpretation. I previously said, "decomposed mortar layers abruptly at stone features rather displaying the customary leaching pattern in which the mortar slopes down concavely from the origin of leaching". Not only the shape but also the content of the mortar layers indicated intentional fill. For besides containing soil and mortar, these layers have heavy concentrations of brick rubble. Whether whole or fragmentary, these bricks are associated with the mortar; many bricks still have hardened mortar attached to them. Brick rubble is not restricted to mortar areas but the near saturation of

mortar layers with brick rubble must be considered a significant correlation.

If we can assume that much of the deposition of the brick and the mortar is contemporaneous, the very presence of the rubble would again suggest intentional fill. It is quite conceivable that the cellar depression was filled with the debris of old buildings which had been moved or torn down. On one side of the equation we have the "supply": a large pile of building rubble that cannot be used again. On the other side of the equation we have a "demand": a depression in the ground that needs to be filled to parade square level to avoid dangerous pitfalls, to maximize the usage of space within the fort, and to facilitate potential building construction.

The volume of mortar suggests intentional fill. Mortar layers have horizontal dimensions equivalent to those of the building and have a layer thickness of over one foot. Average thickness varies from 0.8 to 1.4 feet. These figures represent a rather large volume of decomposed mortar, possibly too large to be the result of either leaching or feature collapse. We should not, however, exclude the possibility of some leaching or structure collapse. It is possible, for example, that originally the brick rubble was located below the mortar and that leaching, aided by melting snows, brought the mortar to the rubble level. This would not, however, invalidate a fill-hypothesis. But there are two minor areas where one of two other processes--leaching or the collapse of a feature containing mortar--may have occurred. One is on top of the S. stone wall in 2E19L, where a typical leaching pattern, previously described, indicates some leaching from the upper wall stones. And a layer of burnt brick and decomposed



mortar which covered as well as surrounded the center stone feature may have been the result of a collapsed brick fireplace and/or chimney. The possibility will be further explored in the interpretation of the center stone feature in section three of this chapter.

A wood ash layer forms the third stratigraphic grouping. It is of limited significance for, unlike the first two groupings, this ash layer is restricted in distribution. It is located in 2E19N and the balk between 2E19N and 2E19P, along the interior face of the E. compound wall. I would estimate its area at about 25 square feet while the average thickness was approximately 0.6 feet. There is a slight east-west gradient to its positioning, the west edge being about 0.7 feet below the east edge. Its vertical location varies somewhat, therefore, depending on the point of measurement. At the gradient middle, the ash layer is between 3.35 and 3.9 feet B.S. or 0.8 feet above the trench bottom (2E19N). In absolute terms, the layer middle is situated between 122.10 and 122.65 feet A.S.L.

The significance of the wood ash layer cannot be discussed without reference to the brick fireplace base located in the same area and already described in chapter 4. The correspondence in location between these two items cannot be ignored. The ash layer has approximately the same horizontal positioning as the fireplace base but is situated between 0.5 and 1.1 feet above the brick base. Nowhere does it come in contact with the base although the wood ash does cover one of the two brick rubble concentrations associated with the fireplace base.

Logically, a functional relationship is expressed by the proximity of the ash to the fireplace base, yet the actual nature of this relationship is somewhat of a puzzle. The ash is restricted to a well-defined layer

above the brick base so that the only physical contact between the two is through a brick rubble concentration. One would expect fireplace ash to be located on or at a level similar to the fireplace base. A vertical gap of one foot between the two suggests possible human interference and questions the logic of any functional relationships. The possibility of wood ash fill (the waste remains of a nearby fireplace) is a potential alternative explanation.

Of the four units that the horizontal stratigraphy was divided into, the first unit (top soil and turf) and the third (primarily mortar) have been discussed. The horizontal stratigraphy has also been interpreted but in general terms. Since these general comments also apply to most of the individual layers, only limited commentary is required for the second and fourth units.

The second unit, which is located between the turf-top soil and the mortar-brick layers, displays the same fill characteristics as have been noticed for the other units. The stratigraphy of unit two probably represents the last fill so that the top layer corresponded to the parade square level at the time of intentional fill. The depth B.S. of the top layer is approximately equivalent to that of the interior brick feature. If this is true, we could establish the surface of operation 19 at the time of fill. The thin layer of very dark brown loam, 10 YR; 2/2, which has limited horizontal distribution, could be the decayed remains of that turf which did manage to grow after fill and before wall collapse.

The fourth and final horizontal unit consisted of rubble-free soil directly below the mortar and brick of the third unit. Our limited knowledge of its horizontal distribution at the time of my departure has hin-

dered any generalizations which we tried to make. But the location and content of these soils does suggest two possible interpretations in terms of origin. One maintains the fill-hypothesis and suggests that the sandy clays of this unit has been intentionally filled in prior to the deposition of the brick and mortar. The second possibility is somewhat different although the occurrence of fill is not to be excluded here either.

Because many of the wooden fragments found in operation 19 were found at the bottom of the third stratigraphic unit and near the top of the fourth, I believe it quite possible that the division between these two units mark the original location of the cellar floor. Other data seems to support this hypothesis. The brick fireplace base in the NE corner of the building was at a level roughly corresponding to the top of the fourth stratigraphic unit. It is that the base would be near floor level, an assumption supported by the brick fireplace bases in operation 2E16-- a Men's Barracks. No intact floor was found but many of the wood fragments that were uncovered, especially the pieces of plank, may be the partial remains of the original floor. Its possible that the floor was removed for use in another building prior to fill. And finally, the absence of significant rubble in the fourth unit, so different from the rubble-laden higher layers, suggests either natural deposition or intentional deposition prior to the cellar fill.

The soils under discussion could be interpreted as: (a) they are the result of natural deposition and were located immediately beneath the floor which the British built. Upon the removal of the floor, the soil was covered by rubble fill; (b) upon completion of wall construction, the area between the floor walls was brought to a level suitable for a floor by

adding high-quality (i.e., rubble free) fill. This fill not only functioned as a platform for the floor but also helped anchor the base of the stone walls; and (c) the soils of the fourth unit were the result of fill after the building had been moved or torn down just like the soil above it. These three alternatives are logical possibilities. In my opinion, however, the evidence supports the second interpretation. The absence of a wall footer trench, as noted in chapter six, adds to the evidence in support of this alternative.

The absence of the footer trench eliminates construction through trenches. The discovery of the fireplace base and the entrance way not only indicate the presence of a cellar or basement but also demands a specific excavation technique. A large rectangular hole with squared sides was dug and the stone walls were erected against the earthen trench sides. Upon completion of the walls, earth was probably thrown into the hole to anchor the walls and to provide a base for the wooden floor. This possibility obviously supports the second alternative with regard to the fourth stratigraphic unit.

I have tried to present a stratigraphic interpretation which recognizes various alternative explanations rather than merely one interpretation. The evidence does support, however, the fill and wall collapse hypothesis which I have presented in this chapter.

### 3. STRUCTURAL INTERPRETATION.

This section on structural interpretation will be divided into the same seven headings as were used in chapter three which described these structures.

(a) walls: both the W. compound wall and the E. compound wall are missing stones along their interior face. This situation was described in chapter 4.

The absence of any rock rubble resembling wall stones in proximity to the interior faces necessitates an interpretation other than just wall collapse. Although wall collapse with subsequent removal of the collapsed stone is theoretically possible, the "neat" steplike edge which has remained as well as the complete lack of evidence for potential collapse among the wall stones still standing, suggests that this possibility should be considered with some reserve.

It has already been said in this chapter that the wooden cellar floor had probably been removed prior to fill. Likely, the material was still in good enough condition to be used elsewhere. The same may be true for the interior face of the East and West compound walls. The construction of new buildings or foundations for moved buildings required stone, field stone for wall cores and worked stone for wall faces. Rather than obtaining and working new stone, the stone from the Officers' Barracks--which was presumably in a state of deterioration or was about to be moved--was used. Since the roughly shaped stones of the interior face of both compound walls was easily obtainable from the building basement, it is quite possible that this occurred.

A collapse hypothesis appears to have very little confirmative evidence. Intentional removal explains not only how it occurred but also why it did. I would suggest that there is not enough evidence to formulate a feasible alternative.

The incomplete corner was described in chapter 4. Excavations in this area were not extensive nor conclusive and I can only offer an interpretive guess. Because the "walls" involved are only one course high, it is unlikely that they helped to support the building. The absence

of a rubble core which would strengthen and support the "wall" also suggests that this corner did not play an essential role in the construction of the building. Instead, the interior wall face and the strong bonded corner functioned as the foundation for the building walls.

The north building wall which has been called the N. shaped stone wall is also the retaining wall of Loudoun's battery. Apparently the constructor felt that they could save time and materials by utilizing the wall that was already standing. It is possible that the stone wall was lined with wood. This would aid construction of the remaining building as well as being more pleasant to look at. It is also possible, although there is no supporting evidence, that a low wall of stones was at one time located in front of (south) the N. shaped stone wall. This wall would have supported the northern wall of the barrack.

(b) counterforts: the four stone counterforts had an obvious function: they supported the N. shaped stone wall. Both the wall and the counterforts were constructed at the same time because they are bonded structures. This did not, however, prevent the top of the wall from collapsing a bit.

What effect the counterforts had on the building interior is difficult to determine. Their physical presence could not be ignored but the officers' quarter would have been built differently had they greatly interfered in indoor life. They may have been associated with room dividers or building supports. Their height above the suspected floor level would not let them function as fireplace bases.

(c) fireplace: as was stated in chapter 4, only one feature in the eastern half of the building could be described as a fireplace base: the brick base in the N.E. building corner. With the

exception of the brick concentration and chimney stone in the western half of the building, there were no other indications of either fireplace structures or bases.

Fireplace bases offer support for the often heavy brick fireplaces and may also protect the nearby floor from accidental fires due to sparks. These probably rested directly on top of the ground (when located on the ground floor or in a cellar) and possibly the brick fireplace was actually mortared onto the base to give it stability. The base in the N.E. corner was a horizontal brick platform. Since none of the base bricks display carbon films or burned surfaces, it is likely that the actual fire never came in contact with the base.

There were no remains of the fireplace itself so nothing can be said about its shape, size, etc. It must be noted, however, that the location of the fireplace is a poor one if optimum heating is desired. The fireplace is hidden in a corner rather than being placed in the middle of one of the room walls. This would be a superior location for it would insure a more evenly distribution of heat--an important factor in a New Brunswick winter. An oven would sooner be placed in a corner than a fireplace.

A small stone wall connects the S.E. corner of counterfort #4 with the north end of the E. compound wall interior face. Possibly there is a functional relationship between this wall and the fireplace. Since both features have been torn down, it will be extremely difficult to ever verify this possibility but it appears likely that the small wall gave support to the fireplace structure as the E. compound wall interior face probably did. Maybe it acted as a base or supported for the northern wall of the barrack.

(d) centre stone feature: there is no obvious interpretation of the centre

stone feature. Its attributes are not so diagnostic as to immediately suggest a feasible explanation. All that we can do is to consider several alternatives.

The feature may have been the base of a fireplace or oven. Its central location would insure optimum heating and accessibility. The dominance of burned brick and decomposed mortar around the feature suggests a fireplace or chimney collapse, and the rather large base could have supported a massive chimney. There is, however, evidence not compatible with this possibility. The top of the feature is irregular and shows no indications of ever having been flat. No mortar or brick rubble was found on top of the feature nor were any of the stones darkened because of fire.

Its central location may be indicative of some function related to the supporting of the rest of the building. At one time, the stones may have continued upwards to the floor of the above storey or wooden posts with their ends on an immovable base of stone may have supported that next floor. There is, unfortunately, no evidence at all to either support or deny this hypothesis.

Because the only building entrance to be uncovered lead into the cellar, there may have been some connection between the cellar and the ground-level floor in the form of a staircase. It is quite logical that this might have been the case, but it must be remembered that ground level entrances are often difficult to detect archaeologically. Even with the existence of an interior staircase there does not have to be a relationship between the centre stone feature and the stairs. There are no indications, such as stepped rocks or stair sill remains, that this stone feature was in any way connected with a stairway.



(e) entrance: little can be said about the exterior entrance for little had been excavated at the time of my departure. It appears that a set of steps led from the parade square into the barrack cellar. The wooden sill was part of the door frame. A post was notched into both ends of the sill and probably served as areas for door hinge attachment. The distance between the posts is 5.2 feet and may have been closed by either two narrow doors or one wider one.

(f) wooden remains: the wooden remains include the seven uprights and scattered horizontal wooden fragments described in chapter four. Various interpretations of the fragments have already been suggested. I noted that no definite floor remains had been uncovered although the round timber running N-S may be the remains of a floor sleeper beam and the several "plank-like" pieces of wood may be floor planking remains. In the discussion on stratigraphic deposition the possibility of floor remains and that of accidental fill material were both suggested.

The eight posts do not form any noticeable patterns. Although there is a grouping of five in the eastern half of the building, the posts could be considered as scattered. Only the function of the eighth post, which is associated with the entrance sill, could be readily determined. This was discussed above. Whether the oval posts served a different purpose from the rectangular posts could not be assayed.

The initial conclusion is that these uprights were either door posts or some form of support post for wall or ceiling. All, however, were broken off near their basal ends so that no hinges, nails, or other signs of function was evident. Nor were there any patterns indicative of either function. Only between the fourth and fifth posts, which are 4.1 feet apart,

was there likely to have been a door. But even these two uprights are not directly opposite each other so no definite statement should be made. Although it is logical that these posts may have been wall uprights, there is no evidence to support this possibility. Again, the random location of these posts given them the appearance of chance occurrences rather than features with intentional functions.

(g) exterior brick feature: the spatial gap between the exterior brick feature and the barrack may reflect the absence of a structural relation. That is, it may not be functionally connected to the barrack in any way. But irregardless of its role, I believe this feature to be of some significance.

Both the Men's Barracks (2E16) and the other Officer's Barracks (2E17) had a brick platform running partially or entirely around the exterior. These bricks had been placed on their sides by the British and they were probably used as a walkway. As such, they must have been located on ground level and are indirectly indicative of parade square level at the time of use.

The exterior brick feature shares some of the "walkway" characteristics but does not possess them all. The bricks are on their edges at a level roughly corresponding to the other walks. The feature is not, however, beside the wall exterior nor are there indications that the brick extended any further than described in chapter 4. In other words, the limited spatial distribution and the physical gap that exists between the feature and the building are evidence contrary to a walk hypothesis. The unique curved edge is also unexplainable in terms of a walkway.

Like so many other features within operation 19, the function of the exterior brick feature cannot be determined. Only the evidence can be

presented and alternative possibilities can be discussed. But like the bricks of 2E16 and 2E17, this feature is probably indicative of parade square level at a time roughly corresponding to the occupation of operation 19. This being so, it would verify parts of my discussion on stratigraphy, especially with regard to original ground levels, turf formation, and fill activities.

(h) general: the historical record indicates that the operation 2E19 building was used as an officers' barrack and was probably a two-storey structure with a cellar (Nadon 1966). No part of the barrack was left above ground so only the building cellar remained to be investigated. What was excavated was apparently the barrack foundation walls, cellar, and cellar entrance; it is unlikely that the ground floor was between four and five feet below the parade square level (if at a level similar to today).

The stone walls which were uncovered are the foundation walls of the barrack. Wooden (?) barrack walls were located on top of the stone foundation. How these were attached has not been solved. A wooden plate (sill) may have been situated on top of the foundation walls (which would be more level than today) with the building walls nailed onto this sill. Or, squared posts may have been driven into the rubble cores of the walls (excluding the N. shaped stone wall) and these would have functioned as studs for the barrack walls. No such post remains had been found when I left the excavation. Along the northern side, the wall planking may have been placed against the N. shaped stone wall or it may have been located a foot or two south of that stone wall so that irregularities in the stone wall would not affect the barrack wall.

Along the S. stone wall, I think that the wooden wall was situated

on top of the rubble core (in the middle of the wall width) while the west and east building walls were probably placed near the interior faces of the W. compound wall and E. compound wall respectively. That is, these two side walls were not in the middle of their foundation walls but rather closer to the interior face. There is NO real evidence to support this suggestion but it might explain why the interior faces of the East and West foundation walls are constructed of shaped stones and why the interior face of the S. stone wall is not. The shaped stones would offer the additional support which would be needed when the barrack wall was not located in the middle of the foundation wall but rather to one side of it. Also, the presence of the "incomplete" S.E. corner would suggest that this part of the wall did not support much of the building wall weight. The interior face of the S.E. corner is complete and the wooden barrack wall could have been located here.

I have suggested that the building walls may have been situated on top the interior faces of the two compound walls. I do not have any explanation however, of why these walls should be compound walls.

The northern wall of the barrack raises more unanswered questions. If the building had been built away from the N. shaped stone wall, why had no stone foundation been uncovered? At one time I thought that the small stone wall which connects the S.E. corner of counterfort #4 with the north end of the E. compound wall interior face may have been the base for the northern barrack wall. If the building wall was built away from the N. stone wall and on top of the interior faces of the West and East stone walls, this might explain why there was a small gap between the two compound walls and the N. shaped stone wall: it wasn't necessary to continue the compound

walls all the way to the N. wall and the gap may also have insured proper water drainage.

It was obvious that several of the upper courses of the N. shaped stone wall were missing and had probably dropped from the wall due to the pressure of the earth behind it. We can only speculate as to its original height. As many as ten courses and as few as eight courses were uncovered during excavation; these had a total height between 6.4 and 8.8 feet. The original wall may have been only ten courses high or it may have had several additional courses. On a scaled but undated cross-section on the British fort plan No. H.M. 15414, the retaining wall of Loudoun's battery is drawn as being about 11.0 feet high. This would suggest that the N. shaped stone wall was at one time two or three courses higher than it is today.

Table 3, to be found at the end of this report(next page), presents a list of all the operation 2E19 brick measurements which I recorded this summer. A few bricks from operation 2E13 were also measured and they are included in the table.

REFERENCES CITED

COLEMAN, Karalee

- 1966 Preliminary Report: Archaeological Excavation at Fort  
Beausejour Historic Park. Operation 2E13 and 2E16,  
National Historic Parks & Sites Branch, Ottawa.

NADON, Pierre

- 1966 Historical Report on Fort Beausejour, unpublished MS,  
National Historic Sites Service, Ottawa.

RICK, John

- n.d. Archaeological Excavation System of the Natural & Historic  
Resources Branch, unpublished MS, National Historic Sites  
Service, Ottawa.

TABLE 1. HORIZONTAL DIMENSIONS AND SURFACE ELEVATIONS OF THE TRENCHES OF OPERATION 2E19.

2E19 sub-operation	Horizontal dimensions in feet		Surface elevations at corners in feet A.S.L.			
	N-S	E-W	NW	NE	SW	SE
A	22	4	125.0	125.0	124.9	125.0
B	23	4	132.2	131.0	124.8	124.8
C	26	12	126.6	129.5	125.1	125.0
D	22	12	125.1	125.0	124.4	124.7
E	22	10	125.0	125.0	124.7	124.9
F	25	10	130.0	131.1	124.9	124.8
G	10	10	124.6	125.1	125.0	125.1
H	13	10	133.4	133.9	125.3	125.7
J	13	10	134.0	133.1	125.6	125.8
K	10	10	125.3	125.2	125.3	125.8
extension to 19K in SW corner	10	4	125.3	125.5	125.6	125.9
L	10	10	125.2	125.2	125.8	126.1
M	13	10	132.7	129.9	125.7	125.8
N	13	10	129.5	128.9	126.0	127.0
P	10	10	125.9	126.7	126.2	126.7
extension to 19P in SW corner	5	7	126.1	126.5	126.8	127.0
V	10	10	125.0	125.3	125.5	125.6

**TABLE 2. LOT-LAYER CORRELATION FOR THE EASTERN HALF OF OPERATION 2E19.**

The abbreviations include: t = top third of a lot; m = middle third of a lot; b = bottom of a lot. Numbers represent lots within each sub-op.

Layer No.	Sub-operation:							
	19G	19J	19K	19L	19N	19P	19Q	19S
1:	1, 2(t-m)	1, 2(t)	1, 2(t-m)	1, 2(t)	1, 2(t-m)	1(t-m)	1,4,8,14, 18,23,28, 32,36,40, 44,48	---
2:	2(m-b), 3, 4, 5, 8(t)	2(t-m), 3, 4(t-m)	2(m-b), 3, 4(t)	2(m-b), 3(t)	2, 3, 4(t-m), 5(t)	3(m-b), 4, 5	2(t),5(t-m), 9,10, 13(t),15, 19,24,29, 33(t-m), 37,41,46, 49	---
3:	4(b), 5, 6(t-m), 8(m)	5, 6	3(b), 4, 5	2(b), 3, 4(t)	---	3(m-b)	2(m-b),16, 21,30,33 (m-b),37 (m),42.50	---
4:	4(b), 5, 6, 7, 8(b)	5, 6	4(b), 5, 6	4	4(t-m)	3(b), 4, 5	3,6,11,12, 13(m),12, 22,26,31, 34,38,43, 47,51	1(b)
5:	---	6	5(b), 6	---	4(m)	---	7,13(b), 27,35,38 (m-b),39, 44	1
6:	---	---	---	---	4(m-b), 5(b)	---	38(m-b)	1
7:	---	---	---	---	---	---	12(b)	1
8:	---	---	---	---	1, 2(t)	1, 2(t-m)	36	---
9:	---	---	---	---	---	2(m-b), 3(t)	37(t)	---
10:	---	4(m-b)	---	---	4(t)	---	5(b),20,25, 33(b),37(m), 42(t),46(b)	---
11:	---	---	---	---	4(m)	---	37(b)	---



TABLE 3. BRICK MEASUREMENTS FROM OPERATIONS 2E13 AND 2E19.

Sub-operation or lot	Number of bricks	Thickness in feet	Width in feet	Length in feet
2E13F9	1	.18	.33	.68
2E13F11	1	.14	.29	.59
	1	.14	.30	.62
	2	.15	.30	.60
	1	.15	.30	.65
	3	.16	.29	.60
	1	.16	.29	.62
	3	.16	.30	.64
	1	.17	.32	.68
	2	.19	.34	.71
2E19C3	1	.13	.30	.62
	1	.15	.30	.62
	1	.16	.30	.62
	1	.16	.30	.63
	1	.17	.35	.72
	1	.17	.37	.72
	1	.17	.37	.73
	1	.18	.37	.75
2E19C4	1	.13	.25	.57
	1	.13	.26	.58
	1	.13	.27	.60
	2	.13	.30	.60
	1	.14	.27	.60
	1	.14	.29	.58
	4	.14	.30	.60
	2	.14	.30	.62
	1	.15	.27	.58
	1	.15	.28	.60
	2	.15	.30	.60
	1	.15	.30	.62
	1	.16	.30	.60
	1	.16	.32	.70
	1	.17	.33	.70
	1	.17	.32	.63
	1	.17	.33	.70
	1	.17	.34	.72
	1	.17	.35	.74
	1	.18	.33	.70
	2	.18	.34	.70
	2	.18	.35	.70
	1	.18	.35	.72
	1	.18	.36	.75
	1	.18	.36	.72
	1	.20	.32	.70
	1	.20	.33	.70
	1	.20	.35	.70
	1	.20	.37	.74
	1	.20	.37	.75

TABLE 3. BRICK MEASUREMENTS FROM OPERATION 2E13 AND 2E19(cont).

Sub-operation or lot	Number of bricks	Thickness in feet	Width in feet	Length in feet	
2E19F	1	.13	.28	.59	
	2	.13	.30	.58	
	1	.13	.30	.61	
	1	.14	.31	.62	
	2	.15	.29	.60	
	1	.17	.34	.65	
	2	.17	.35	.70	
	1	.18	.27	.65	
	1	.18	.32	.67	
	1	.18	.33	.70	
	1	.18	.33	.73	
	1	.19	.27	.61	
	1	.19	.27	.63	
	1	.19	.27	.65	
	1	.19	.31	.73	
	1	.19	.32	.68	
	1	.19	.32	.70	
	1	.19	.34	.57	
	1	.19	.34	.71	
	1	.19	.35	.73	
	1	.19	.36	.68	
	2	.20	.29	.65	
	2	.20	.32	.70	
	1	.21	.28	.67	
	1	.22	.27	.68	
	2E19F3/F4	1	.12	.30	.58
		1	.13	.28	.60
		1	.13	.30	.60
		1	.14	.28	.58
		1	.14	.28	.60
5		.14	.30	.60	
5		.14	.30	.62	
1		.14	.31	.60	
1		.14	.31	.62	
1		.15	.27	.58	
1		.15	.28	.60	
1		.15	.29	.60	
1		.15	.29	.63	
2		.15	.30	.60	
1		.15	.30	.61	
3		.15	.30	.62	
2		.15	.30	.63	
1		.15	.32	.62	
1		.16	.28	.60	
1		.16	.30	.60	
1	.16	.30	.65		
1	.17	.31	.68		
1	.17	.35	.70		

TABLE 3. BRICK MEASUREMENTS FROM OPERATIONS 2E13 AND 2E19(cont).

Sub-operation or lot	Number of bricks	Thickness in feet	Width in feet	Length in feet
2E19F3/F4(cont)	1	.18	.28	.60
	1	.18	.29	.60
	1	.18	.30	.60
	1	.18	.33	.68
	4	.18	.33	.70
	2	.18	.34	.70
	2	.18	.35	.70
	1	.18	.36	.70
	1	.19	.30	.63
	1	.19	.32	.70
	3	.19	.35	.70
	1	.19	.37	.74
	1	.20	.27	.68
	1	.20	.28	.68
	1	.20	.29	.66
	1	.20	.30	.69
	1	.20	.31	.64
	1	.20	.33	.70
	1	.20	.35	.73
	1	.20	.37	.72
2E19F10	1	.28	.35	.70
	1	.12	.26	.58
	1	.12	.28	.58
	1	.13	.25	.58
	1	.13	.27	.58
	1	.13	.28	.60
	1	.13	.30	.62
	1	.14	.26	.57
	4	.14	.28	.58
	1	.14	.28	.60
	1	.14	.28	.62
	5	.14	.30	.60
	1	.14	.30	.62
	1	.15	.27	.60
	1	.15	.28	.60
	1	.15	.28	.62
	9	.15	.30	.60
	3	.15	.30	.62
	1	.15	.30	.64
	1	.16	.30	.60
1	.16	.32	.70	
1	.17	.30	.65	
1	.18	.25	.67	
1	.18	.28	.65	
1	.18	.30	.68	
1	.18	.32	.68	
1	.18	.32	.70	
2	.18	.33	.68	

TABLE 3. BRICK MEASUREMENTS FROM OPERATIONS 2E13 AND 2E19(cont).

Sub-operation or lot	Number of bricks	Thickness in feet	Width in feet	Length in feet	
2E19F10(cont)	2	.18	.33	.70	
	1	.18	.34	.68	
	1	.18	.34	.70	
	1	.18	.35	.74	
	2	.20	.28	.65	
	2	.20	.28	.68	
	2	.20	.30	.65	
	1	.20	.30	.70	
	1	.20	.33	.68	
	2	.20	.35	.74	
	2E19G	1	.13	.25	.57
		1	.13	.29	.55
		1	.13	.30	.60
		1	.13	.30	.62
1		.14	.28	.55	
3		.14	.28	.58	
5		.14	.30	.60	
2		.14	.30	.62	
1		.14	.32	.68	
2		.14	.32	.68	
2		.15	.25	.55	
2		.15	.28	.58	
2		.15	.28	.60	
4		.15	.30	.60	
3		.15	.30	.62	
1		.15	.30	.63	
1		.15	.30	.68	
1		.15	.32	.60	
3		.15	.32	.65	
4		.15	.32	.63	
1		.15	.33	.68	
1		.16	.33	.70	
1		.17	.34	.72	
1	.18	.30	.58		
1	.18	.32	.70		
1	.18	.33	.71		
1	.18	.34	.72		
1	.18	.35	.72		
2E19H	1	.14	.27	.55	
	1	.14	.29	.60	
	1	.14	.30	.60	
	1	.14	.30	.61	
	1	.14	.31	.63	
	1	.15	.26	.60	
	1	.15	.28	.60	
	3	.15	.30	.60	
	1	.15	.32	.65	
	1	.16	.36	.72	
	1	.17	.30	.62	

TABLE 3. BRICK MEASUREMENTS FROM OPERATIONS 2E13 AND 2E19(cont).

Sub-operation or lot	Number of bricks	Thickness in feet	Width in feet	Length in feet
2E19H (cont)	1	.19	.35	.72
2E19J	1	.13	.27	.55
	1	.13	.28	.58
	1	.13	.30	.61
	2	.14	.28	.58
	1	.14	.30	.63
	1	.14	.31	.61
	1	.15	.30	.60
	2	.15	.30	.62
	2	.16	.32	.70
	1	.17	.34	.65
	1	.18	.34	.71
2E19K	3	.13	.28	.58
	1	.13	.30	.60
	1	.13	.30	.62
	1	.13	.34	.65
	1	.14	.28	.58
	3	.14	.28	.60
	1	.14	.33	.67
	1	.15	.28	.58
	3	.15	.30	.60
	1	.15	.30	.62
	1	.15	.30	.63
	1	.15	.30	.64
	1	.18	.28	.68
	1	.18	.35	.75
	1	.20	.22	.64
2E19L	1	.13	.24	.51
	1	.13	.25	.59
	1	.13	.30	.60
	2	.14	.28	.60
	1	.14	.29	.56
	1	.14	.29	.58
	1	.14	.29	.60
	1	.14	.30	.60
	1	.15	.25	.57
	1	.15	.28	.59
	1	.15	.30	.60
	1	.16	.28	.60
	1	.16	.29	.59
	2	.17	.32	.70
	1	.18	.36	.72
	1	.19	.34	.70
	1	.20	.33	.70
2E19N	2	.13	.29	.60
	1	.14	.25	.55
	1	.14	.28	.63
	2	.14	.29	.61
	3	.15	.28	.60
	3	.15	.29	.60

TABLE 3. BRICK MEASUREMENTS FROM OPERATIONS 2E13 AND 2E19(cont).

Sub-operation or lot	Number of bricks	Thickness in feet	Width in feet	Length in feet	
2E19N(cont)	1	.15	.30	.59	
	3	.15	.30	.62	
	2	.15	.30	.64	
	2	.15	.31	.64	
	1	.16	.29	.61	
	2	.16	.30	.62	
	1	.16	.34	.64	
	1	.17	.33	.65	
	1	.17	.34	.70	
	1	.18	.25	.65	
	1	.18	.33	.71	
	1	.18	.35	.71	
	1	.19	.26	.66	
	1	.19	.28	.68	
	2E19P	1	.14	.29	.58
		1	.14	.29	.61
		1	.15	.28	.58
1		.15	.29	.58	
1		.15	.30	.60	
3		.15	.30	.61	
2		.15	.30	.63	
1		.15	.32	.63	
1		.15	.33	.65	
1		.16	.29	.59	
2		.16	.30	.60	
1		.16	.30	.61	
1		.16	.31	.65	
1		.16	.32	.64	
1		.17	.27	.61	
1		.17	.30	.65	
1		.17	.33	.70	
1	.18	.35	.72		
1	.18	.36	.70		
1	.19	.35	.72		
1	.20	.35	.67		
2E19Q17	1	.13	.28	.58	
	2	.13	.30	.62	
	2	.15	.28	.60	
	4	.15	.30	.60	
	1	.15	.30	.62	
	1	.18	.36	.70	
	1	.20	.32	.70	
1	.20	.35	.70		



Report on the Archaeological Excavations at  
Fort Beausejour, New Brunswick, 1966  
by Francois Trudel



## CONTENTS

<u>2E</u> - Introduction.....	1
<u>2E13</u> - Prince Henry Bastion	
Sub-operation 2E13E .....	2
Sub-operation 2E13H .....	7
Sub-operation 2E13J .....	10
<u>2E16</u> - Barracks	
A - Drain .....	13
B - Window .....	17
C - Barracks' Wall .....	19
D - Oven .....	19
E - Fireplace .....	22
F - Partitions .....	23
G - Floor .....	24
H - Joists .....	26

LIST OF FIGURES

Figure 1. Brick floor & sides of oven.....29  
Figure 2. Fireplace, facing north.....30

## INTRODUCTION

2E-

The author's research work in Fort Beauséjour during the months of June, July and August, 1966, may be divided into two distinct periods: first, the month of June was devoted to training in archaeological excavation techniques, in close co-operation with Mr. Jervis D. Swannack, Jr., Project Archaeologist, and his chief assistant, Miss Karalee Coleman, with whom I carried out excavations on the escarp of the salient, the terreplein and the right face of the Prince Henry Bastion (SUB-OPERATIONS 2E13A, 2E13C, 2E13D, 2E13G and 2E13E).

During the second period (July and August), I was put in charge of my own sub-operations and resumed additional excavations in sub-operation 2E13E (at the corner of the right shoulder of the Bastion) before starting work on sub-operations 2E13H and 2E13J (internal slopes of embrasures, left face of Bastion).

Moreover, the northern section of operation 2E16, i.e., the barracks located on the parade ground, was excavated (SUB-OPERATIONS 2E16A, 2E16B, 2E16E, 2E16F, 2E16G, 2E16H and 2E16Q). Again the archaeologist and his assistant gave me valuable advice during the excavation work.

This partial report will deal only with the sub-operations which I supervised in Prince Henry Bastion (2E13E, 2E13H, and 2E13J) and the

parade ground, in the northern part of the barracks, and I shall only endeavour to bring out the structural aspects of the discoveries made during the summer.

2E13 - Prince Henry Bastion

SUB-OPERATION 2E13E

A seven-foot (N.S.) by twelve-foot (E-W) trench was defined in the early part of the season, between two merlons, at the interior of the right shoulder of the Bastion, to uncover the probable existence of a gun-platform. This particular embrasure was selected over the others because of the low height of the merlons, in order to save time and effort. However, this initial trench was extended northward no less than four times, by means of a series of 3' x 3' excavations, following the discovery of three joists (or remains of joists), roughly parallel to each other and pointing directly southeastward toward the embrasure.

Before these extensions were carried out, the four initial lots (2E13E1 to 2E13E4) had yielded a few wood pieces, the longest not exceeding 2", two nails and a post in the southeast corner of the sub-operation. A pattern began to emerge only after the first northward extension trench (2E13E5), when timbers having their fibers lying in a southeasterly direction, as well as two more nails, were found beneath the rubble fill. This led us to deepen the excavation by about one inch, on the average, and to remove the fill (2E13E6). Part of a joist, with three nails imbedded in it, then emerged on the west side, as well as indications of another parallel joist,

with two nails, on the east side, and of a concentration of nails at a point midway between the two joists, but to the south (cf. plan 66-8-D4).

The next extension trenches (2E13E7-8-9-10-11), excavated to uncover the remainder of the joists and establish their pattern, brought to light further portions of the first two joists and a third middle joist roughly parallel to the others, with a single nail imbedded in it.

Work in this sub-operation has discontinued when the tip of the longest joist (on the west side) was reached, midway in the last extension trench.

#### I - Joists

The uncovered timbers were wooden beams about 3-5" thick, with an average width of 4-5", and of varying lengths:

- (A) Joist, west side: 13.1' long
- (B) Middle joist: 3.9' long
- (C) Joist, east side: 6.9' long

The distance between inside edges of the timbers varied from 1.6' to 2.15', the latter being recorded to the north. The whole timber arrangement had a southeasterly orientation, and the platform would have been rectangular-shaped, measuring about 5' x 13', assuming that all the joists making up the platform had been found. No indication of reinforcing or special supporting material, such as stones or mortar, was found under

the joists, and the elevations suggest that the platform had no front or back slope, unless the timber and the nails have been significantly disturbed.

## II - Nails

Number of nails found: 30

The nails apparently belonged to two main types: the first, with lengths varying between 4 and 5 inches, was quite limited in number, whereas the second, much more frequent, all 6" long, were found mainly in the joists.

The nail distribution strongly suggests that the gun-platform was covered with planks placed at right angles to the joists. The distance between the nail head and the point of contact with the joist approximates the thickness of the boards used to cover the gun-platform. The elevation of the nails in the joists varied from 133.1' to 133.4' A.S.L.; that of the nails not in the joists, from 132.6' to 133.4'. The elevations recorded on the joists were as follows:

- (A) Joist, west side: south: 133.1' A.S.L.  
center: 133.2' A.S.L.  
north: 133.1' A.S.L.
- (B) Middle joist: south: 133.3' A.S.L.  
north: 133.3' A.S.L.
- (C) Joist, east side: south: 133.3' A.S.L.  
north: 133.3' A.S.L.

The height variation lies, therefore, between 0 and 3 inches, and it may be assumed that boards up to 3" thick were used as planking.

The post (height, 135.9' A.S.L.) and the tip of the beam (height, 136.2') found along the south wall of the initial trench may have been part of the gun-platform or the merlon structure immediately adjacent to the opening of the embrasure, as support for the joists; however, they appear too far away from the platform area. This hypothesis would require the existence of a fourth joist, for which no evidence has been found, except possibly for two nails uncovered at a height of 135.98' and 136.0' respectively, i.e., much above all the rest of the nails. <sup>(1)</sup> It is more likely that the stake was associated with the merlons immediately adjacent to the embrasure.

The artifacts found shed no light on the use of the gun-platform. Two cannon-balls (Neg No. 66x291), found alongside the east joist, may have belonged, from their diameter, to a 12-lb gun, but this hypothesis, to be acceptable, needs to be carefully checked out, as the gun-platform appears rather small to accommodate a 12-lb. gun.

However, it would seem that we are dealing with a genuine gun-platform, rather than a howitzer-platform: the timber arrangement appears roughly parallel, but the south edges may have been placed in closer juxtaposition, such a structural arrangement providing a considerable increase in platform stability.

(1) See plan 66-8-D4.

(1)  
PLAN

Gun-platform

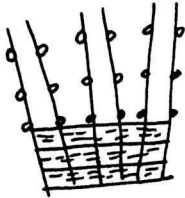

Howitzer-platform



It must be added that the engraving referred to is of British origin, whereas the gun-platform was possibly located in a French occupation level.

Lack of a rail highly restricted gun mobility; however, such mobility may also have been dependent upon the type of carriage used.

PLAN

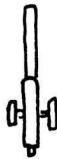

Increased mobility, with a gun carriage

(1) S. James Gooding. An Introduction to British Artillery in North America.





Limited mobility, without a gun carriage

#### SUB-OPERATION 2E13H

This sub-operation, a trench 10 feet wide (E-W) and 20 feet long (N.S.), located along the left face of the Bastion, was excavated for the purpose of obtaining information on:

- (1) the structure of the merlons;
- (2) and possibly, of the existence of a  
gun-platform in the embrasure between  
two merlons.

However, no conclusive evidence was actually found as to the existence of a definite structure, except for six partial or complete

posts, from 3 to 6 inches in diameter, all lying in a row.

With respect to merlons, Pierre Nadon, in his historical report, states that:(1)

- (A) In 1755, they were "caisons of timber filled with earth."
- (B) In 1766, they "were wooden boxes filled with earth, five feet high, ten broad on the inside, and five feet thick sloping towards the top."

However, no evidence of such structures was found. There is only one stratigraphic indication that might be related to merlons: a cross-section of the trench (66-8-D1) shows the occurrence of pure clay layers only at the merlon stratigraphic level, and not at the embrasure level. If the section of trench 2E13H and the balk are joined, it is found that the stratum where the clay layers were observed is 14' wide, i.e., the hypothetical width of a merlon. Between the 17th and 18th foot of section 2E13H, two wood fragments (1" wide and 1" thick, 3" wide and 1" thick) were also found, that were probably part of the merlon structure.

It is possible that the pure clay layers are earth fill that settled through the timbers used for the construction of the merlons.

Posts:

Mention has been made earlier of the discovery of six posts and two post holes.

(1) Nadon, 1966. Draft Report, p. 63.

Hypotheses:

- (1) These posts would be the first row of the French double palisade, reported to be 14' high outside and 9' high inside (before 1752). The butt ends of the posts were about 7 feet above the surface of the parade ground.

Elevations: Taken at the tops -- south to north.

Hole No. 1:	133.0'
Hole No. 2:	133.0'
Stake No. 1:	132.7'
Stake No. 2:	132.8'
Stake No. 3:	132.65'
Stake No. 4:	132.5'
Stake No. 5:	132.5'
Stake No. 6:	132.3'

- (2) In 1763, "after the revetment collapsed into the ditch, a palisade row was built on the bastion" (Pierre Nadon, 1966 Draft Report, p. 62).

The exact location of this palisade is not given, nor is there any mention of its demolition or dimensions, but the posts, fragments of posts and post holes may be part of this English palisade, more likely to be preserved as it was erected at a later date.

- (3) It is doubtful that these posts were used to affix a gun-platform structure;

- (A) first, the posts are spread over a distance of about 27 feet, behind the embrasures and the merlons, and gun-platforms are not generally erected behind a merlon; [unless it is a continuous platform]
- (B) if the posts had been used to affix the platform structure, they would not be placed in a row, but would follow a more or less rectangular pattern behind the embrasure.

#### SUB-OPERATION 2E13J

The prime purpose of this sub-operation was to further investigate the row of posts discovered in sub-operation 2E13H, and possibly to gather more data on the merlon and gun-platform structure. Little evidence was uncovered in the first two lots, but the next three yielded interesting results.

In Lot 2E13J3, fragments of timbers or wooden planks, with the fibers orientated from north to south, were first discovered, along with nails of varying lengths (1 to 5 inches) and part of what appeared to be a joist with an east-west orientation.

The next lot (2E13J4) was found to contain the butts of two other posts (diameter, 0.15'; elevations, 133.1' and 133.0') in line with those uncovered in sub-operation 2E13H.

The last lot in this sub-operation yielded the butt end of at least three other posts and two more planks with the fibers east-west orientated.

Are these fragments part of the merlon, the palisade or the gun-platform? All the possible hypotheses seem partially conflicting.

- (A) If the posts are part of the presumed palisade excavated in sub-operation 2E13H, why is the eastern-most post in the trench at the same height as the plank, if the latter is part of the gun-platform? It would have been probably impossible to erect the platform without first cutting the posts to make way for this structure.
- (B) If the posts were used to affix the timbers of the gun-platform, why is the most southernmost post, A (See plan) almost midway across the joist, and why would post B appear to have no practical use whatsoever, allowing that the gun-platform is made up of only three timbers?
- (C) If the gun-platform hypothesis is accepted, together with the explanation that the row of posts was used to affix the joists, it must be assumed that the posts found in sub-operation 2E13H are also timber fastenings for a gun-platform, but the most likely hypothesis with respect to sub-operation 2E13H is then negated.

#### PROBABLE HYPOTHESIS

There is one hypothesis that does not exclude the possible existence of a palisade (either of French or English construction) along

the left face of the Bastion. Briefly, a gun-platform would have been first erected, then, due to structural alterations (reference has been made to the collapse of the revetment and also to building alterations as a means to avoid raking fire), the palisade would have been constructed behind the gun-platform, the latter, meanwhile, being abandoned or replaced by a new structure probably further back and to the west.

#### OPERATION 16 - Barracks

This new operation on the parade ground was roughly defined before excavating by a depression next to the curtain, between Prince Henry Bastion and Prince Frederick Bastion.

Instead of dealing with each successive sub-operation, as for the preceding operation, we shall consider as a whole the structures unearthed during the excavations of the sub-operations in OPERATION 16, first discussing what has been termed a drain, then the revetment, the windows, the wall of the building, the oven, the hearth, the partitions, the wood and brick floor and, finally, the joists.

Again I shall mainly endeavour to bring out the structural aspects of the excavated material.

(A) DRAIN

SUB-OPERATIONS 2E16A, B, E, F, G, H, Q.

The first material recovered by the excavation was a series of rows of red bricks on edge adjacent to one another, running from north to south (west side, exterior of the barracks) and from east to west (north side, exterior of the barracks), virtually non-existent on the east side, merging in the northeast and northwest corners. Several westward and northward extension trenches indicated that this structure covered an average distance of 5'3" from the inside to the outside and led at the northwest corner to a shallow northwesterly orientated drain-canal made with the same type of brick and in a very bad state of preservation.

PLAN (not to scale)

(1) Typical brick arrangement



(2) Outer edge brick arrangement



(3) Drain-canal brick arrangement

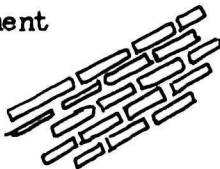

(4) Corner brick arrangement

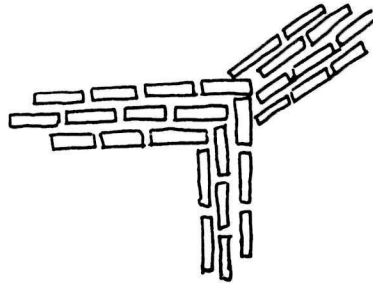

The exact elevation of this structure could not be easily determined, but it may be said that it ranged from 125.2' to 126.5' around the northern section of the building.

Two hypotheses may be set forth with respect to this first structure, to wit:

- (A) The evidence suggests the presence of a brick walk around the building, to avoid wet and muddy areas. If this was the case, however, why was the brick structure interrupted over a distance of 11 feet on the west side of the building, thus putting an obstacle in the path of people going from the northwest corner to the southern section of the building?
- (B) If this was a drain, the difficulty remains, because such a structure cannot be discontinued over a distance of 11 feet, unless guttering was present on the roof.

Therefore, it must be assumed that, directly facing the structure, there was a brick pattern similar to the one that was excavated,



i.e. bricks laid out lengthwise from east to west and used as a drain or a walk, or both. This variation in the brick arrangement would be due to the presence of a door in front of the structure. Some sections of the drain have vanished or were never built, for some unknown reason. In sub-operation 2E16E, especially, the drain structure is abruptly discontinued on the west side over a distance of 11 feet. In the northeast corner, bricks from this structure become gradually scarce and, along the east wall of the building, virtually non-existent.

In fact, so limited was the number of bricks uncovered on the east side that it was decided to increase the depth of the extension trenches. This led to an interesting discovery in these extensions 2E16F5 and 2E16H5 and in the control wall (2E16Q8). This structure, made of dry-laid masonry, differs from what was found by Coleman outside the east wall in the southern section of the barracks. For one thing, the stones are more massive and natural-looking; for another, they are laid along two rows gradually curving in at the ends to disappear into the wall of the trench.

The unearthed structure is made of dry-laid masonry, lies about .5'-1' above the parade ground and is similar to a revetment that might have been used for a gun-platform or as a fill between the curtain and the foundations of the wall of the building, about 7 to 13 inches away.

This wall structure may date from the French, although there is no direct evidence yet at hand, and could be:

- (A) a revetment for the terreplein of the curtain;
- (B) a protective fill between the terreplein of the curtain and the walls of the building;
- (C) or both;
- (D) or a revetment for a gun-platform on the terreplein, behind the parapet, though no gun embrasure in the curtain is described on the plans. However, two depressions indicating possible embrasures in the curtain can be seen at present.

To verify these various hypotheses, it would have been necessary to excavate the whole structure, but time was lacking for such a major operation.

The fact remains, however, that the drain or walk around the building may have lain in a quite recent occupational level. It has been said earlier that the excavation work outside the east wall of the barracks yielded but scarce fragments of the drain. The hypothesis of an east side drain as extensive as on the west side is favoured because the alluvial material from the roof, the rampart and the terreplein had to be effectively controlled, lest the basement floor of the building become flooded. It is likely that the bad state of repair of the drain structure on the east side (northern section) is mainly due to the precipitous slope of the curtain and, therefore, to possibly more rapid soil movements.

The disposal of the drainage water offered something of a problem, in that the northeast corner leads directly to the interior re-entering angle of Prince Henry Bastion, and it is not determined whether the drain waters were totally directed to the northwest corner, or whether the northeast corner led directly into the bastion.

B - Window (SUB-OPERATION 2E16E, 2E16Q16, 2E16A)

This structure was located close to the outside of the west wall of the building, and three similar structures were excavated under the direction of K. Coleman further to the south along the same side of the building. More or less square-shaped, it was made of bricks and stones. The external stone facing was still present on the north, west and south sides, but missing on the east side. The bricks had been laid flat at a level about a foot below the stones and orientated lengthwise in an east-west and north-south direction.

It was noted that the brick disposition, west of this structure, followed a different pattern: rather few and far between, they were not laid on edge, but flat, and pointed lengthwise in an east-west direction only. The absence of bricks on a 2.2' east-west stretch leading from the structure seems odd in this case, because the brick drain/walk is not interrupted in front of the similar structures discovered by K. Coleman, although the bricks in front of one of them are scarce.

A noteworthy feature is the absence of a sill on the east side of the window; this eliminates the possibility of a door or window casement.

Several plausible hypotheses may be put forward in regard to the identification of this structure, namely:

- (A) it may be the threshold of a door leading, not to the cellar of the barracks, as no stairs were found, but more likely to the ground floor. However, it may be objected
  - (a) that the cellar would then be of quite low height, in view of the low level of the excavated structure (elevation, 124.2') compared to the floor (elevation, 121.1').
  - (b) that the door would be at a lower level than the drain, thus requiring the existence of a structure (stairs) for conveniently reaching the drain from the threshold, unless the whole structure has considerably subsided below the drain level, which is most unlikely, since the north side and middle section of the structure have the same elevation (measured on the bricks, 124.2').
- (B) it may be a window:
  - (a) from the actual approximate elevation of the whole structure, a person standing up in the cellar would have been able to open or close the window;
  - (b) the absence of a stone window-sill on the east side suggests that one or two hinged windows had been probably installed;
  - (c) bricks may have been laid out next to the edge of the stone siding for drainage purposes.

### C. Barracks Wall

This is a masonry wall of roughly hewn, often field stones, a large part of which collapsed inward rather than outward. Almost no significant stone fragments were found on the exterior, except at the northeast corner of the building (See Neg. Nos. 66x801, 66x802). Only one of the two corners of the wall was excavated, the other (if it is still standing) remaining buried under the structure of what would be an oven (Neg. No. 66x862). However, the lower part of the wall, on both the east and west sides, was undisturbed and is still well-preserved; from this, the exact interior width of the building, 17.7' was found, the wall itself being up to 1.3' thick. The height of the wall at the northwest corner is 3.45'. At the level of the wooden floor, a baseboard about 0.3' wide and 0.03'-0.05' thick was found running along the base of the interior partition wall, except in the northwest corner, in what might have been the coal-cellar.

Mortar was used between the stones of the wall. No evidence was found of plastering or panelling applied to the interior face of the walls.

### Oven (Sub-operation 2E16B)

The northeast corner of the building was concealed by a structure, a semi-circular oven made chiefly of bricks, with the inclusion of a few stones. Width, 4.5'; depth, 4.45' (without the cut stones) and 5.85' (with the cut stones). Two types of brick were used, characterized as follows:

Type I: length, 0.72'  
width, 0.35'  
height, 0.2'

Type II: length, 0.63'  
width, 0.28'  
height, 0.16'

The westernmost cut stone (at the mouth of the oven, which is on the south side) had the following measurements:

length, 2.65'  
width, 1.4'  
height, 0.45'

whereas the dimensions of the stone on the east side were as follows:

length, 1.4'  
width, 1.4'  
height, 0.6'

Two elevations were recorded, the first on the cut stone (123.5'), the second on the oven flooring (123.6'). The difference in height between the barrack floor level and the oven floor level was estimated at 2.4'. The oven flooring consisted of bricks laid flat, with a north-south orientation (See photo No. 1 ), while the oven walls were also made of bricks exhibiting at least three distinct arrangements.

(A) Brick Arrangement

viewed from the side: bricks laid flat.



viewed from above



(B) Brick Arrangement

viewed from the side: bricks laid flat.



viewed from above

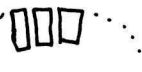

(C) Brick Arrangement

view from the side: bricks laid on end.



viewed from above



Location of the brick arrangements:

- (A) at the back of the oven
- (B) on the sides of the oven
- (C) probably all around the oven, in between the two other types.

The slope of the bricks suggests an arched (dome-shaped) type of oven. One thing should be pointed out concerning this structure: from

the brick flooring, level with the floor of the barracks, to the lower face of the cut stones, an admixture of broken bricks, earth and decomposed mortar was noted, but this situation could not be explored before my departure from the site, because the structure had to be left undisturbed for photography and drawing purposes. It appears that the brick flooring stretching up to the east wall was built for some purpose, and not just for the central fireplace (compare, for instance, with the fireplace at the south end of the building, which is flanked on both sides by a wooden flooring.) This brick floor may have been used as a shield against the heat and fire of a double fireplace (second fireplace being at a level lower than the oven) or of the oven itself. In the case of the oven, heat for cooking purposes may have come from the central fireplace. However, why was there some decomposed mortar under the cut stones? We assume that the oven was a later addition, constructed in fill - possibly over another, earlier fireplace. Further excavations will have to be undertaken before any definite hypothesis may be put forth.

### Fireplace

The fireplace was located at the centre of the north wall; it is somewhat rectangular in shape, with a width of 3.3' at the back, of 3.95' at the front, and a depth of 2.05'. The width of the cut base (?) stones varied from 0.75' to 1.9', with an approximate thickness of 0.45'. (Fig. 2). A kind of partition was found on the west side of the fireplace, possibly erected for heat-shielding purposes. The distance from the north wall to the end



of the partition was 4.0', the partition width being 2.07'. The length of the brick flooring was 4.2' from the back of the hearth to the wooden flooring (N-S), and 10.4', from the east wall to the west edge of the bricks.

From these discoveries, the following structural data may be deduced: the wall bases of the hearth were made of cut stones and covered with bricks laid flat, orientated north-south and east-west axes. It is likely that the back wall of the fireplace sloped inward. (See sketch below)

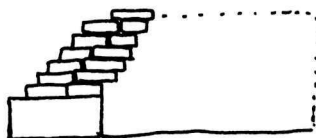

The fragments of bricks and mortar found in the neighbouring lots (2E16B, F) suggest that the chimney was also made of red brick and may have collapsed inward.

#### Partitions

The first partition excavated was located at a distance of 6.75' south from the brick flooring surrounding the fireplace and the oven. This 13.2' long, 1.9' wide partition was made chiefly of field stone joined with mortar and laid directly on earth. It was at right angles to the east wall and ran westward up to the entrance of a 3 foot wide door. A 0.66' by 0.4' post was also uncovered at this location next to the west wall of the

barracks, adjacent to a stone projecting out at floor level from the wall. It may have been the post on which the door hinges were affixed, or it may just as well have been located on the side of the opening of the door. However, a single hinge was found on the floor, next to the west wall; this hinge could very well have been disturbed. This hinge is the only evidence available; therefore, it is quite insufficient to infer on what side the door opened.

The second partition was located at a distance of 5.85' from the first and was parallel to it. This structure, 13.1' long and 2.2' wide, was also interrupted by the entrance to a door with a width of 3.05'. Another post, similar to the one found in the door of the first partition, 0.775' by 0.5' was also found adjacent to the west wall and a similar stone as stated previously.

### Floor

The floor, made up of planks laid at right angles to the joists, was still in notably good condition, at least in the northern section. The dimensions of the planks were as follows: maximum width, 1.05'; average width, 0.8'; thickness 0.1'; maximum and minimum length, 17.6' and 3.15'. The orientation of the planks was from east to west, compared with the joists (from north to south).

These boards were attached to the joists by nails, 0.34' in average length, but with two different types of head.

In one instance, the nail head was entirely located on one side of the nail body; in the other, the nail head was exactly centered on the nail body. The planks were nailed at both ends and at the point of contact with each of the joists. However, around the fireplace and the oven, this wooden planking was replaced by a red brick flooring, measuring 10.4' from east to west and 4.2' from north to south. The central part was used as flooring for the fireplace, whereas the section still covered may have been a shield against oven heat or the flooring of another fireplace, although the latter is doubtful, since the lengthwise brick pattern changes to an east-west orientation.

At floor level, in the second partition from the north, fragments of three timbers were excavated, measuring respectively, from east to west:

First timber: length, 2.0'  
width, 0.67'  
thickness, 0.28'

Second timber: length, 3.1'  
width, 0.67'  
thickness, 0.24'

Third timber: length, 1.8'  
width, 0.7'  
thickness, 0.25'

It should be noted that these timbers are nearly all of the same width and thickness. It is believed that they were not part of the door structures at the end of the partitions, due to the difference in thickness between the door posts and these timbers. It is possible that, in spite of their relative thinness, they were associated with the beams supporting the basement floor.

### Joists

The floor-supporting joists or sleepers were north-south orientated, from 0.35 to 0.45' wide and 0.66' thick (measured from a point on the third timber starting from the west, third partition, south of the northern section). Numbering 7, sometimes 8, they were located in each individual partition; only one spanned the whole northern section, starting from the north wall of the building. All the joists were parallel and the shortest timber supported the planking of the second door (numbered from the north side) entrance.

A problem remains regarding the north-south orientation of the timbers. Usually, joists are placed at right angles to the main side walls, not parallel to them, as in this case. The following hypothesis is submitted:

It has been seen that the first partition is 6.75' away from the brick oven flooring, and the second, 5.85' from the first. Since the width of the whole building is 17.7', a perpendicular beam arrangement would have required timbers long enough to reach both the east and west walls.

It is believed that the timbers were laid out in this direction because of a shortage of long beams or of their use being restricted to the super-structure of the building. Needless to say, this type of arrangement required more labour, since a greater number of timbers had to be used.



2E - 1299 - X

Fig. 1  
Brick floor and sides  
of oven, looking EAST



Fig. 2 -- Fireplace, facing north. Dots indicate base stones of the fireplace referred to in the text.





1966 Preliminary Report of Archaeological  
Excavations at Fort Beausejour, N.B.  
by K.A. Coleman

## ABSTRACT

IN THE SEASON OF 1966 I EXCAVATED TWO OPERATIONS AT FORT BEAUSEJOUR: PRINCE HENRY BASTION, AND THE MEN'S BARRACKS. IN THE FORMER, I EXPOSED TRACES OF THE LOG-AND-EARTH CONSTRUCTION OF THE RAMPARTS AND A STONE REVETMENT ON THE SALIENT ANGLE ABOVE THE DITCH. IN THE TERREPLEIN, BESIDES A STONE INTERIOR REVETMENT AND AN AMBIGUOUS BRICK PLATFORM, I FOUND A WOODEN CASEMATE, BASTION-SHAPED, MEASURING 27' WIDE AND 61' LONG, WITH AN ADDITIONAL 19' OF ENTRANCE STRUCTURES. IT HAD A ROUGH LOG ROOF, A WELL-PRESERVED LEVEL FLOOR, AND A WOOD AND STONE PORCH. THIS STRUCTURE WAS PROBABLY OCCUPIED FROM 1753 TO 1755.

THE MEN'S BARRACKS CONSISTED OF MASONRY REMAINS 71' LONG BY 17.5' WIDE, SURROUNDED BY A BRICK AND STONE WALK/DRAIN. IT CONTAINED FIVE INTERIOR PARTITIONS WITH FOUR DOORS, AT LEAST TWO SUPERIMPOSED WOODEN FLOORS, FOUR WINDOWS, AND THREE FIREPLACES WITH FOUR HEARTHES AND AN OVEN. THE LEVEL EXPOSED AT PRESENT WAS OCCUPIED AROUND 1800.

## TABLE OF CONTENTS

INTRODUCTION . . . . .	1
OPERATION 2E13. PRINCE HENRY BASTION. . . . .	3
RAMPART CONSTRUCTION AT SALIENT ANGLE . . . . .	5
THE FRENCH CASEMATE . . . . .	9
ARTIFACTS . . . . .	17
REVETMENT . . . . .	19
BRICK PLATFORM. . . . .	20
OPERATION 2E16. THE MEN'S BARRACKS . . . . .	22
BRICK DRAIN. . . . .	25
WALLS. . . . .	28
DOORS. . . . .	31
FLOOR. . . . .	33
WINDOWS . . . . .	36
FIREPLACES . . . . .	40
ARTIFACTS . . . . .	46
APPENDIX I. PLATES. . . . .	49
APPENDIX II. DRAWINGS. . . . .	69
APPENDIX III. BRICKS . . . . .	97

## TABLE OF FIGURES

FIG. 1.	2E13 OPERATION PLAN . . . . .	4
FIG. 2.	2E13 BRICK PLATFORM . . . . .	21
FIG. 3.	2E16 OPERATION PLAN . . . . .	23
FIG. 4.	2E16 RELATIVE LOCATION OF STRUCTURES. . . . .	24
FIG. 5.	2E16 DOORWAY. . . . .	32
FIG. 6.	2E16 FLOOR AND BASEBOARD. . . . .	35
FIG. 7.	2E16 WINDOWS. . . . .	37
FIG. 8.	2E16 MANTEL STONE . . . . .	41
FIG. 9.	2E16 CHIMNEY STONE. . . . .	43

## INTRODUCTION

FROM MAY 30 TO SEPTEMBER 23, 1966, I PARTICIPATED IN EXCAVATIONS AT FORT BEAUSEJOUR NATIONAL HISTORIC PARK IN AULAC, NEW BRUNSWICK. THE WORK WAS DONE UNDER THE DIRECTION OF JERVIS D. SWANNACK, JR., FOR THE ARCHAEOLOGICAL RESEARCH SECTION, CANADIAN HISTORIC SITES DIVISION, DEPARTMENT OF INDIAN AFFAIRS AND NORTHERN DEVELOPMENT.

MY WORK WAS DONE FIRST WITH THE ASSISTANCE OF, AND LATER IN CONJUNCTION WITH, FRANCOIS TRUDEL, A STUDENT AT LAVAL UNIVERSITY. WE SHARED A CREW OF LABOURERS WHICH SELDOM EXCEEDED ELEVEN IN STRENGTH. THE CREW WAS COMPRISED OF THE FOLLOWING MEN:

EDGAR VOUTOUR

RON OGDEN

JOHN DIXON

BILL GOODWIN

HARRY MACDONALD

RICHARD JONES

WINSTON ALLEN

GERALD GOODWIN

BRUCE DAVIS

FULTON BRADLEY

BRUCE COMEAU

IRVING TRUEMAN

JIM COUSINS

JOHN MAHONEY

JIM CHAPMAN

MR. TRUDEL AND I EXCAVATED PRINCE HENRY BASTION (OPERATION 2E13) AND A STRUCTURE ON THE PARADE SQUARE BETWEEN PRINCE HENRY AND PRINCE FREDERICK BASTIONS WHICH IS REFERRED TO AS THE MEN'S BARRACKS (OPERATION 2E16).

MR. TRUDEL IS REPORTING ON THE GUN PLATFORMS AND PALISADE OF THE BASTION AND ON THE NORTH END OF THE BARRACKS. THE FOLLOWING IS THE REPORT ON MY PARTICULAR AREAS OF CONCENTRATION: A DISCUSSION OF RAMPART CONSTRUCTION, DESCRIPTION OF THE PARTIALLY EXCAVATED FRENCH CASEMATE IN PRINCE HENRY BASTION, AN OVERVIEW OF THE MEN'S BARRACKS, AND A DETAILED ANALYSIS OF THE SOUTH AND CENTRAL PORTIONS OF THE BARRACKS.

APPENDICES TO THIS REPORT CONTAIN ILLUSTRATIONS OF MAJOR AREAS OF DISCUSSION INCLUDING PHOTOGRAPHS AND DRAWINGS, AND A PRELIMINARY QUANTITATIVE STUDY OF BRICKS USED IN THE CONSTRUCTION OF THE MEN'S BARRACKS AND THE SO-CALLED OFFICERS' BARRACKS (OPERATION 2E17).

K. A. COLEMAN

## OPERATION 2E13. PRINCE HENRY BASTION

IN PRINCE HENRY BASTION, MY EXCAVATIONS WERE COMPRISED BASICALLY OF A LONG, DISCONTINUOUS TRENCH BISECTING THE BASTION FROM ESCARP TO PARADE SQUARE. THE TRENCH CONSISTED OF THE FOLLOWING SUB-OPERATIONS [SEE OPERATION PLAN, FIG. 1, P. 4]:

2E13A: MEASURES 22' EAST-WEST BY 12' NORTH-SOUTH. IT EXTENDS FROM THE TOP OF THE PARAPET AT THE SALIENT ANGLE TO A POINT ABOUT HALF WAY DOWN THE ESCARP, JUST BEYOND THE BERM. IN THIS SUB-OPERATION WE CONSIDER THE STRUCTURE OF THE RAMPARTS. IT WAS EXCAVATED TO A MAXIMUM DEPTH OF 9.5' B.S.

2E13C: LIES 15.6' WEST OF 2E13A, LEAVING THE PARAPET AT THE SALIENT ANGLE UNEXCAVATED. THE SUB-OPERATION MEASURES 29' EAST-WEST BY 12' NORTH-SOUTH, AND EXTENDS DOWN AN AVERAGE 7' B.S., TO THE TOP OF THE CASEMATE ROOF.

2E13D: CONTINUES IMMEDIATELY WEST OF 2E13C, AND HAS IDENTICAL DIMENSIONS.

2E13G: CONTINUES IMMEDIATELY WEST OF 2E13D, AND MEASURES 25' EAST-WEST BY 12' NORTH-SOUTH. IT INCLUDES ONLY THE INTERIOR TALUS, EXTENDING FROM THE EDGE OF THE TERREPLEIN TO THE EDGE OF THE PARADE SQUARE. LIKE THE OTHERS, IT WAS EXCAVATED TO THE TOP OF THE CASEMATE ROOF, WITH A MAXIMUM

2E13 OPERATION PLAN

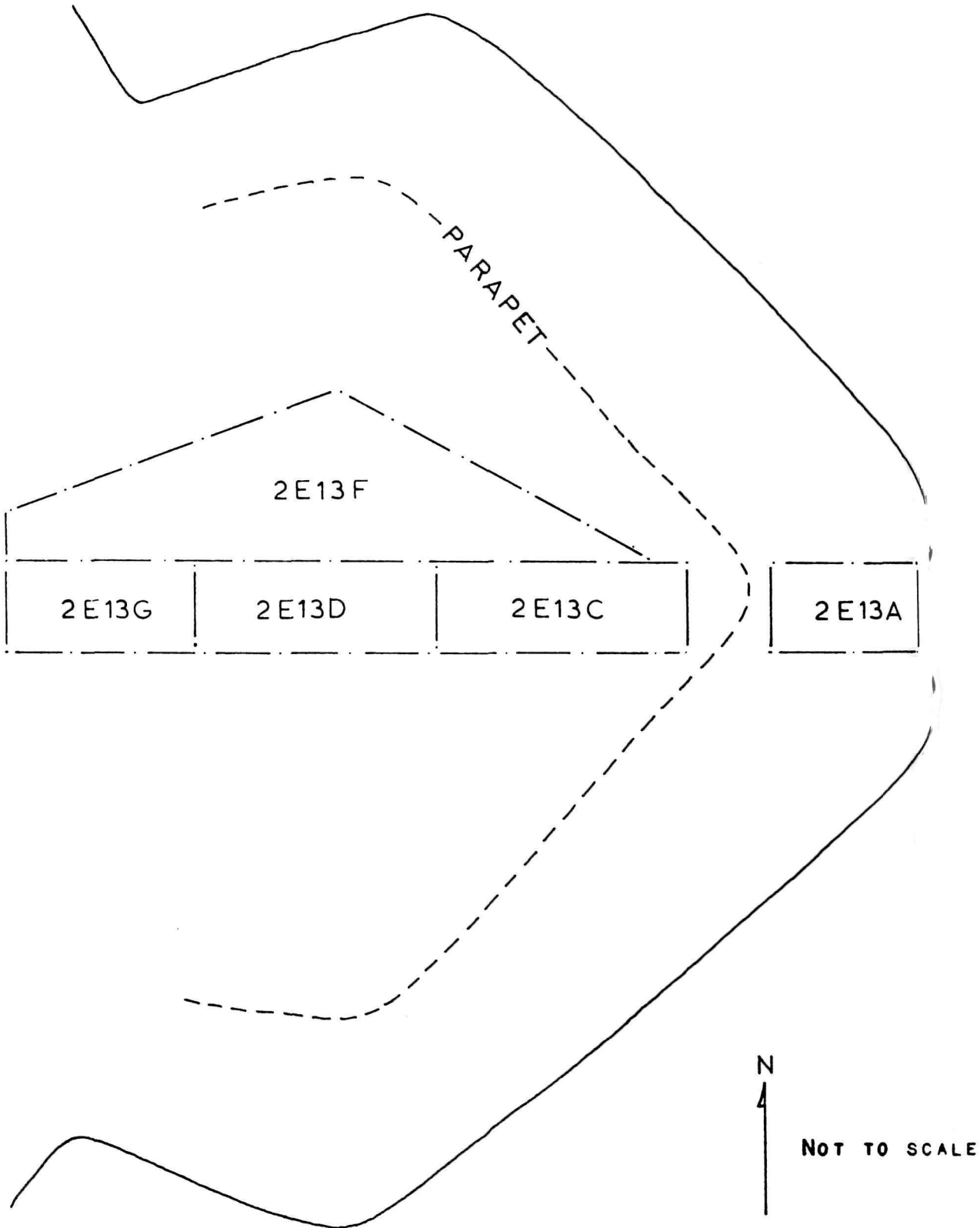

FIG. 1



DEPTH OF 6' B.S.

2E13F: IS AN IRREGULARLY-SHAPED EXTENSION OF 2E13C, D, AND G TO THE NORTH. IT IS A MAXIMUM OF 77' EAST-WEST BY 18' NORTH-SOUTH, AND IS ROUGHLY TRIANGULAR. IT ALSO EXTENDS TO THE TOP OF THE CASEMATE ROOF, AND WAS FOR THE MOST PART EXCAVATED BY BACKHOE.

2E13K: IS THE CASEMATE ITSELF, FROM THE TOP OF THE ROOF DOWN. SO FAR, EXCAVATION IN THIS SUB-OPERATION CONSISTS OF THREE NARROW, SHALLOW TRENCHES DUG ACROSS THE CASEMATE TO ITS FLOOR.

#### RAMPART CONSTRUCTION AT SALIENT ANGLE

BEFORE EXCAVATION, THE ESCARP AT THE SALIENT ANGLE OF PRINCE HENRY BASTION SLOPED DOWN STEEPLY FROM THE PARAPET TO THE DITCH, BROKEN JUST ABOVE THE HALF-WAY POINT BY A SMALL CRESCENT-SHAPED PLATFORM. WE HOPED THAT THIS PLATFORM WOULD CONTAIN THE FOUNDATIONS OF A GUERITE WHICH WAS REPORTED TO HAVE BEEN LOCATED IN THAT POSITION, BUT FOUND NO SIGN OF ANY SUCH STRUCTURE.

WE DID FIND BROKEN BRICK AND STONE RUBBLE ON THIS PLATFORM, IMMEDIATELY BELOW SOD LEVEL, BUT SIMILAR RUBBLE WAS ALSO FOUND JUST OVER THE TOP OF THE PARAPET. RATHER THAN RESEMBLING A COLLAPSED BUILDING, THE PATTERN OF THE RUBBLE INDICATED THAT AT SOME TIME, SOMEONE HAD TAKEN A LOAD OF

RUBBLE ONTO THE BASTION AND DUMPED IT OVER THE EDGE: IT HAD DRIBBLED DOWN THE SLOPE, WITH THE MAJORITY OF IT BECOMING TRAPPED ON THE PLATFORM.

I DO NOT BELIEVE THAT THE LEVEL ON WHICH THIS RUBBLE RESTED WAS ORIGINALLY A BERM, BUT WAS MORE RECENT FILL WHICH HAD TO SOME EXTENT MAINTAINED THE ORIGINAL CONTOUR OF THE ESCARP. IN ANY CASE, THE HISTORIC SITES DIVISION'S GLOSSARY OF MILITARY TERMS USED IN FORTIFICATIONS DEFINES THE FUNCTION OF A BERM AS "TO PREVENT THE EARTH FROM ROLLING INTO THE DITCH": THEREFORE, BY UNINTENTIONAL OR DELIBERATE MEANS, THIS PLATFORM SERVED THE PURPOSE OF, AND THUS IS, A BERM.

ALTHOUGH THE SEARCH FOR THE GUERITE PROVED FUTILE, THE EXCAVATION OF 2E13A REVEALED SOME INTERESTING INFORMATION ABOUT RAMPART CONSTRUCTION.

HISTORIC DOCUMENTS STATE THAT THE RAMPARTS WERE CONSTRUCTED OF LAYERS OF WOOD AND BEATEN EARTH. THIS REPORT HAS NOW BEEN VALIDATED IN PART. AT AN ELEVATION OF 129.0' A.S.L. A ROW OF SEVEN HORIZONTAL POST HOLES, ORIENTED PARALLEL TO THE LEFT FACE OF THE BASTION, WAS EXPOSED [SEE PLATE 1, APPENDIX I, AND DRAWING 1, APPENDIX II]. THE POST HOLES WERE ABOUT 0.3' IN DIAMETER, AND OF UNDETERMINED LENGTH (MAXIMUM EXPOSED WAS 6' LONG). CLOSER INSPECTION OF THE WEST FACE OF THE TRENCH REVEALED ANOTHER ROW, AVERAGING 0.9' ABOVE THE FIRST ROW, THIS TIME ORIENTED PARALLEL TO THE

RIGHT FACE OF THE BASTION. ABOVE THAT, OUR PROBING OF THE NOW DRY FACE YIELDED THE BEGINNINGS OF MORE POST HOLES, RANDOMLY SPACED AND APPARENTLY NOT ARRANGED IN ROWS [SEE DRAWING 2, APPENDIX 11].

THE WOOD CONTENT OF THE RAMPARTS SLOPES OUT STEEPLY WITH THE SLOPE OF THE ESCARP, AND NEVER EXTENDED RIGHT TO THE FACE OF THE ESCARP.

THIS CONSTRUCTION CAN HARDLY BE DESCRIBED AS "LAYERS" OF WOOD AND BEATEN EARTH. RATHER, THE RELATIVELY WIDELY SPACED BRANCHES AND THIN TREE TRUNKS SHOULD BE REFERRED TO AS BONDING, VAGUELY SIMILAR TO THE SPACED METAL RODS IN REINFORCED CONCRETE.

DOCUMENTARY EVIDENCE STATES THAT THE ESCARP WAS FACED WITH MORE THAN JUST SOD. LAWRENCE, IN 1754, SAID IT WAS FACED WITH STONE [NADON, P, REPORT ON FORT BEAUSEJOUR, SECTION B, "STRUCTURAL EVOLUTION 1751-1755", P. 5], AND LATER THAT IT WAS FACED WITH TIMBER [IBID., SECTION B, P. 5]. ANOTHER REPORT STATES THAT IT WAS FACED WITH STONE TO THE HEIGHT OF THE DITCH [IBID., SECTION F, "BASTIONS", P. 4]. A FURTHER REPORT MENTIONS A REVETTING OF DRY STONE FOR THE HEIGHT OF THREE FEET WITH A SLOPE OF TWO FEET [IBID., SECTION F, P. 1].

AT AN ELEVATION OF 128.5' A.S.L., 6.5' ABOVE THE PRESENT DITCH LEVEL, I ENCOUNTERED AN 8' WIDE ROW OF LARGE, IRREGULAR STONES SET DRY IN A STRATUM OF DARK REDDISH-BROWN SANDY CLAY

[SEE DRAWING 1, APPENDIX II; PLATE 2, APPENDIX I]. THIS RUBBLE-BUILT REVETTING WAS PARALLEL TO THE LEFT FACE OF THE BASTION, AND PRESUMABLY CONTINUED AROUND THE SALIENT ANGLE TO THE RIGHT FACE. I ALSO PRESUME IT EXTENDS DOWN TO THE DITCH (MINIMUM ELEVATION 122' A.S.L.): NO EXCAVATION WAS DONE TO VERIFY EITHER OF THE LAST TWO STATEMENTS. SEVERAL PIECES OF WOOD WERE FOUND AMONG THE STONES, BUT NO ARTIFACTS WERE ENCOUNTERED ANYWHERE WITHIN THE DARK REDDISH-BROWN STRATUM.

UNEXPECTEDLY, THE STRATUM IN WHICH THE STONES ARE SET SLOPES DOWN INTO THE RAMPART RATHER THAN AWAY FROM IT. THIS WOULD INDICATE THAT THE REVETTING WAS NOT SIMPLY PLACED ON THE OTHERWISE FINISHED ESCARP. EITHER A TRENCH WAS CUT INTO THE ESCARP FOR IT, RISKING COLLAPSE, OR THE LINE OF STONES WAS SET FIRST, WITH THE RAMPART BEING BUILT UP OR EXTENDED INSIDE IT AFTER IT WAS FINISHED [SEE DRAWING 3, APPENDIX II].

THE ORIGINAL FACE OF THE ESCARP (OR, RATHER, THE FACE OF THE ESCARP CONTEMPORARY TO THE STONE REVETTING DESCRIBED ABOVE) SLOPES DOWN FROM THE PARAPET MORE STEEPLY THAN THAT IN EXISTENCE TODAY. THE FORMER HAS A GRADIENT OF 9:5, WHILE THE LATTER IS 2:5. THIS SLOPE CONTINUES TO A POINT WHICH IS AT THE SAME ELEVATION AS THE TOP OF THE STRATUM CONTAINING THE REVETTING, 2.5' INSIDE IT. FROM THERE, THE ORIGINAL FACE CONTINUES ALMOST HORIZONTALLY ACROSS THE TOP OF THE REVETTING, THEN MOVES STEEPLY DOWN AGAIN. THIS PROFILE

YIELDS A FAIRLY WIDE (13') BREAK IN THE ESCARP, WHICH SERVES EITHER AS A BERM OR AS A BASE FOR THE GUERITE, IF SUCH A FEATURE EXISTED.

NONE OF THE FEATURES I HAVE DESCRIBED ABOVE--"BERM", STONE REVETTING, OR WOOD BONDING--WAS FOUND IN 2E11D OR 2E11E, THE ONLY OTHER TRENCHES DUG IN THE ESCARP THIS SEASON. PRESUMABLY THE REVETTING IS A FEATURE OF SALIENT ANGLES ONLY: OR POSSIBLY ONLY OF PRINCE HENRY BASTION, ALTHOUGH THIS SEEMS RATHER IMPROBABLE. THE BERM AS WELL (IF SUCH IT WAS INTENDED TO BE) COULD BE RESTRICTED TO SALIENT ANGLES, BUT IT SEEMS UNUSUAL THAT NO SIGN OF WOOD BONDING WAS FOUND ELSEWHERE.

#### THE FRENCH CASEMATE

SUB-OPERATIONS 2E13C, D, F AND G EXPOSED THE ROOF OF A LARGE WOODEN CASEMATE IN PRINCE HENRY BASTION, WHILE SUB-OPERATION 2E13K HAS SO FAR YIELDED A SMALL AMOUNT OF INFORMATION ABOUT WHAT LIES BENEATH THAT ROOF.

THE BASTION-SHAPED CASEMATE, WHICH IS APPROXIMATELY 27' WIDE AT THE WIDEST POINT AND 61' LONG FROM DOOR TO SALIENT ANGLE, WITH AN ADDITIONAL 19' OF APPROACH STRUCTURES, LAY AN AVERAGE 7' BELOW THE SURFACE OF THE TERREPLEIN AT AN AVERAGE ELEVATION OF 127.0' A.S.L. NONE OF THE SIDES WAS COMPLETELY EXPOSED BUT, ASSUMING THAT THEY ARE STRAIGHT,

THEY WOULD MEASURE AS FOLLOWS: RIGHT FLANK 46' LONG; LEFT FLANK 42.5' LONG; RIGHT FACE 21.5' LONG; LEFT FACE 22.5' LONG. CLEARING THE MASS OF EARTH ABOVE THIS WAS A LONG, TEDIOUS CHORE, INVOLVING WELL OVER 2,000 MAN-HOURS OF HAND LABOUR AND  $1\frac{1}{2}$  DAYS OF BACKHOE TIME.

APPROACHING THE ROOF, WE ENCOUNTERED A BRICK PLATFORM [SEE PP. 20, 21], A STONE REVETMENT [SEE P. 19], AN UNREWARDING ASH PIT, AND OF COURSE SOME STRATIGRAPHIC EVIDENCE RELEVANT TO THE CAVE-IN OF THE STRUCTURE. OTHER THAN THESE FINDS, VIRTUALLY NOTHING BROKE THE MONOTONY OF HAULING AWAY LAYER AFTER LAYER OF OTHERWISE UNDISTURBED, ALMOST STERILE FILL.

THE ASH PIT WARRANTS MENTION AT THIS POINT. IT WAS FOUND IN THE NORTHWEST CORNER OF 2E13C, I.E. ON THE LONGITUDINAL AXIS OF THE CASEMATE, SEVEN FEET EAST OF THE MIDDLE OF THAT AXIS AND, APPROPRIATELY, SEVEN FEET WEST OF A LINE WHICH CAN BE PROJECTED TO JOIN THE SHOULDER ANGLES OF THE CASEMATE. THE ASH PIT IS THUS SITUATED IN WHAT MAY BE CONSIDERED TO BE THE STRUCTURAL CENTER OF THE CASEMATE, JUST WEST OF THE POINT WHERE WE FOUND THE LONGEST REMAINING 8" X 8" SUPPORT BEAM (WHICH, INCIDENTALLY, HAD FALLEN), HENCE AT THE POINT WHICH WOULD MANIFEST THE GREATEST CONCAVITY IMMEDIATELY AFTER COLLAPSE.

THE ASH PIT, THOUGH LACKING WELL-DEFINED BORDERS, WAS CONTAINED IN A RECTANGLE MEASURING 7' EAST-WEST BY 4' NORTH-

SOUTH. THIS RECTANGLE CONSISTED BASICALLY OF DARK BROWN LOAMY SAND WITH CHARCOAL, CHANGING TO DARK REDDISH BROWN SANDY CLAY WITH PEBBLES AT THE BOTTOM. IN THE MIDDLE WAS AN OVAL-SHAPED AREA, 2.8' NORTH-SOUTH BY 1.4' EAST-WEST, CONTAINING A THICK CONCENTRATION OF CHARCOAL, OYSTER SHELLS, WOOD, AND (UNLIKE THE SURROUNDING AREA) ARTIFACTS, INCLUDING A LOCK, A COIN, A SLUG, SEVERAL NAILS, GLASS AND CERAMIC SHERDS.

THE ASH PIT WAS ENCOUNTERED AT A DEPTH OF 4.1' B.S., AND DISAPPEARED AT 5.6' B.S.

IN CONTENT AND RELATIVE LOCATION THIS ASH PIT RESEMBLES A UNIQUE, NEAR-VERTICAL DEPOSIT OF OYSTER SHELLS AND MISCELLANEOUS ARTIFACTS FOUND FURTHER WEST, IN 2E13D. BOTH OCCUR AT THE POINT WHERE THE DARK REDDISH-BROWN STRATUM [STRATUM 3, DRAWINGS 5 AND 6, APPENDIX II] BEGINS TO SLOPE STEEPLY DOWN AS A RESULT OF THE COLLAPSE OF THE CASEMATE ROOF. HOWEVER, THE 2E13D DEPOSIT APPEARS TO PRE-DATE THE COLLAPSE, AS THE SHELLS ETC., THOUGH VERTICAL, MAINTAIN THE ARRANGEMENT THEY SHOULD HAVE HAD WHILE HORIZONTAL. THIS DOES NOT SEEM TO BE THE CASE WITH THE 2E13C ASH PIT. RATHER, ITS LOCATION SUGGESTS THAT IT WAS BUILT UP IN A HOLLOW CREATED BY THE COLLAPSE.

DOCUMENTARY EVIDENCE STATES THAT BY 1784 MUCH RECONSTRUCTION WAS DONE IN THE FORT. PRESUMABLY BY THAT TIME THE CASEMATES

HAD COMPLETELY COLLAPSED, IN WHICH CASE THE TERREPLEINS HAD DEVELOPED GORGES. THESE REQUIRED SOME FILLING. IT IS POSSIBLE THAT THE RUBBLE FOUND ABOUT 1' B.S. IN THE TERREPLEIN OF PRINCE HENRY BASTION IS THE RESULT OF THIS FILLING ACTIVITY.

SOME OF OUR LABOURERS RECALL RUBBISH BEING DUMPED IN THE FORT, WHICH MIGHT EXPLAIN THE RUBBLE REFERRED TO ABOVE. HOWEVER, VERY RECENT GARBAGE WAS FOUND IN OPERATION 2E16, WHICH MAY BE WHAT THEY REMEMBER, OR THEY MAY BE REFERRING TO THE OLDER BUT, JUDGING FROM THE ARTIFACTS, STILL MODERN DEPOSITS FOUND ON THE INTERIOR TALUS OF THE BASTION. THAT DEPOSIT FOUND ON THE TERREPLEIN IS COMPLETELY DIFFERENT IN NATURE: THE FORMER CONSISTED OF BURNED WOOD AND ARTIFACTS, WHILE THE LATTER WAS MAINLY BRICK AND STONE RUBBLE. THERE DOES NOT THEN APPEAR TO BE ANY EVIDENCE TO CONTRADICT MY PROPOSALS.

IN ANY CASE, THERE WAS ENOUGH EARTH BETWEEN THE STONE RUBBLE AND THE VARIOUS ASH-SHELL DEPOSITS TO MAKE THE PROCEDURE OF DATING ONE INDEPENDENT OF THE DATE OF THE OTHER (RELATIVELY SPEAKING), SO THAT WHILE THE DATE OF THE FORMER IS OPEN TO CONJECTURE, THAT OF THE LATTER IS NOT.

I PROPOSE THAT BOTH ASH-SHELL DEPOSITS ARE POST-FRENCH OCCUPATION IN ORIGIN, SINCE THE CASEMATES APPEAR TO HAVE BEEN OPERATIVE UNTIL THE BRITISH TAKE-OVER. POSSIBLY THAT



IN 2E13D DATES AROUND 1755-1760, DURING THE FIRST PERIOD OF CASEMATE DECLINE, WHILE THAT IN 2E13C IS UNDOUBTEDLY PRE-1784 IN ORIGIN, IF NOT CONTEMPORARY TO THE FORMER.

THE CASEMATE ITSELF WAS A LONG, NARROW, LOW BUILDING. THE FLOOR LAY AT AN ELEVATION OF 126.0' A.S.L., 8' BELOW THE PRESENT TERREPLEIN LEVEL. PRESUMABLY THE TERREPLEIN IS NOW AS HIGH AS IT EVER WAS (AVERAGE 134.0' A.S.L.), IF NOT HIGHER. GIVEN THAT BOTH THE FRENCH AND THE BRITISH COMPLAINED THAT THERE WAS NOT NEARLY ENOUGH FILL OVER THE CASEMATES TO BOMB-PROOF THEM, THERE MUST HAVE BEEN AT LEAST 1' OF FILL OVER THIS CASEMATE AS SOD LEVEL 1 (STRATUM 4, DRAWING 5, APPENDIX II) IS ALMOST 1' THICK OVER MUCH OF THE STRUCTURE. THE ROOF ITSELF, CONSISTING OF UNTRIMMED LOGS AVERAGING 0.5' THICK, AND THE CENTER BEAM, WHICH IS ALSO 0.5' THICK, ACCOUNT FOR AT LEAST ONE MORE FOOT OF VERTICAL SPACE. AT BEST, THEN, THE CASEMATE MIGHT HAVE HAD 6' OF CLEARANCE.

THE CASEMATE MUST HAVE HAD A TWO-PITCHED ROOF, WHICH WOULD FURTHER REDUCE ITS CLEARANCE. POSSIBLY IT WAS COMPLETELY A-FRAME, TRANSVERSE SALT-BOX STYLE, BUT THE PRESENCE OF TWO UPRIGHTS ALONG THE LEFT FACE WOULD APPEAR TO INDICATE [LOW] VERTICAL SIDES. IN ANY CASE, THE ROOF WAS IN NO WAY WATERPROOFED, SO THE PERPETUALLY SEEPING RAINWATER, LIBERALLY DOUSING THE FORT, WOULD HAVE HAD TO HAVE BEEN DRAINED OFF SOMEHOW: A FLAT ROOF ON THE CASEMATE, WITH THE RESULTING DRAINAGE PROBLEM, WOULD MAKE IT USELESS NOT ONLY FOR SHELTER

BUT FOR STORAGE AS WELL, NOT TO MENTION THE STRUCTURAL DISADVANTAGES OF A FLAT ROOF IN AN AREA WHICH MUST SUPPORT THE PASSAGE OF MEN AND CANNONS.

WHEN WE EXPOSED IT, THE ROOF CONSISTED OF A LAYER OF UNTRIMMED THIN LOGS, RANDOMLY DISTRIBUTED THROUGHOUT THE CONFINES OF THE CASEMATE BUT GENERALLY ORIENTED NORTH-SOUTH [SEE DRAWING 4, APPENDIX II]. NO NAILS WERE FOUND IN THIS BADLY PRESERVED WOOD. A CANNON BALL WAS IMBEDDED IN THE ROOFING MATERIAL ON THE RIGHT FLANK AND AN ANVIL AND BARREL WHICH RESTED ON THE FLOOR HAD THRUST THEIR TOPS THROUGH THE COLLAPSED DEBRIS. THE REMAINS OF TWO 8" X 8" UPRIGHT BEAMS PROTRUDED A FEW INCHES ABOVE THE ROOF ON THE LEFT FACE, WHILE A THIRD LONGER BEAM (3' LONG, TO BE PRECISE) LAY WHERE IT HAD FALLEN AFTER BREAKING, JUST EAST OF CENTER ON THE LONGITUDINAL AXIS OF THE BUILDING. NO OTHER SUPPORT BEAMS WERE FOUND. BENEATH THIS MASS OF WOOD LAY THE CENTRAL ROOF BEAM (0.5' X 0.8'), BISECTING THE STRUCTURE FROM SALIENT ANGLE TO AN AS YET UNDETERMINED POINT INSIDE THE DOORWAY. THIS BEAM AS WELL HAS NOT YET YIELDED ANY NAILS, ALTHOUGH TO DATE LITTLE OF IT HAS BEEN EXPOSED [SEE PLATE 3, APPENDIX I].

THE CENTRAL ROOF BEAM RESTED DIRECTLY ON THE FLOOR. THE REST OF THE ROOF WAS SEPARATED FROM THE FLOOR BY A MILDLY VISCOUS LAYER OF REDDISH BROWN SANDY CLAY VARYING FROM 0.2' TO 1' THICK.

THE FLOOR ITSELF, WHERE EXPOSED IN THREE NARROW TRENCHES, WAS EXTREMELY WELL PRESERVED, POSSIBLY BECAUSE IT WAS WET, AND COMPARED TO REMAINS ON THE REST OF THE SITE APPEARED IN ALMOST NEW CONDITION. THERE WERE NO SPACES BETWEEN THE BOARDS (WHICH WERE ALL APPROXIMATELY 0.9' WIDE), AND APPARENTLY ALL NAILS WERE INTACT AND SCARCELY CORRODED. THE AFOREMENTIONED NAILS OCCURRED ALONG THE TWO EXPOSED SEAMS, TWO NAILS PER BOARD. BOARDS RAN EAST-WEST, OR LONGITUDINALLY, AND THE TRANSVERSE SLEEPERS RAN NORTH-SOUTH. THE THICKNESS OF THESE BOARDS, THE SLEEPER PATTERN, AND THE FURTHER DISTRIBUTION OF NAILS REMAIN TO BE DETERMINED.

AT THE SALIENT ANGLE OF THE CASEMATE, THE ONLY REMAINING SECTIONS OF WALLS WERE FOUND. THESE CONSISTED OF ONE BOARD-WIDTH ON THE LEFT AND TWO ON THE RIGHT, LYING HORIZONTALLY ON EDGE ALONG THE FACES. ELSEWHERE, FLOOR AND COLLAPSED ROOF MET WITHOUT BENEFIT OF WALLS, ALTHOUGH THE LINE WHERE THEY HAD BEEN WAS VISIBLE.

THE ENTRANCE TO THE CASEMATE IS MOST CURIOUS. IMMEDIATELY ADJACENT TO THE LOCATION OF THE FRONT WALL IS A WOODEN "PORCH", SIX FEET WIDE (NORTH-SOUTH) AND EIGHT FEET LONG (EAST-WEST). IT IS MADE OF FOUR TRANSVERSE TIMBERS TOO BADLY PRESERVED FOR DIMENSIONS TO BE GIVEN, COVERED ORIGINALLY BY BOARDS OF WHICH LITTLE NOW REMAINS. NO NAILS WERE NOTED IN THE WOOD. ON EITHER SIDE, WOOD EDGING MAY INDICATE ORIGINAL "TUNNEL" WALLS. THIS PORCH PROBABLY LED TO A LOW,

WIDE DOORWAY WHICH MAY OR MAY NOT HAVE HAD A DOOR--NO DOOR FURNITURE WAS FOUND.

THE ENTRANCE PORCH, LIKE THE FLOOR OF THE CASEMATE, WAS AT AN AVERAGE ELEVATION OF 126.0' A.S.L.

CONTINUING EAST FROM THE PORCH IS AN ODD PATTERN OF ROCKS, OF WHICH WE EXPOSED 11 FEET. THESE ROCKS START OUT AS THREE CONVERGING ROWS, FROM EITHER SIDE AND THE MIDDLE OF THE PORCH. ORIGINALLY WOODEN BOARDS OVERLAID THE STONES, AND APPARENTLY PROJECTED BEYOND THEM--TO THE SOUTH AT LEAST. FIVE AND A HALF FEET FROM THE PORCH, THE CENTER ROW OF STONES STOPS. THE OTHER TWO ROWS CONTINUE TO CONVERGE UNTIL APPROXIMATELY 10' FROM THE PORCH, AT WHICH POINT THEY FORM A SINGLE LINE OF STONES WHICH APPEARS TO CONTINUE WEST TO SOME UNKNOWN DESTINATION [SEE PLATE 4, APPENDIX 1].

THIS STRUCTURE IS OBVIOUSLY NOT A DRAIN. IN THE 11 FEET WE EXPOSED, THE ELEVATION OF THE BOTTOM OF THE STONES DROPS 0.3', FROM 125.3' A.S.L. TO 125.0' A.S.L. HOWEVER, DRAINS DO NOT USUALLY CONSTRICT SO RADICALLY (I.E. TO THE POINT OF BECOMING ALL WALL AND NO PASSAGE). IT IS NOT POSSIBLE THAT THIS WAS AT ONE TIME A CLEAR PASSAGE WHICH HAS SINCE BEEN FORCED TOGETHER, AS THE CONSTRICTED END OF IT DOES NOT OCCUR NEAR A SLOPE OR ANY OTHER SOURCE OF UNEVEN PRESSURE. IT WAS BUILT MUCH THE WAY WE NOW SEE IT, I AM CERTAIN. FURTHERMORE, IT IS TOO NARROW TO BE A PATH, AND I DOUBT

THAT THE FORT EVER SAW A SEASON WET ENOUGH TO WARRANT STEPPING STONES ACROSS THE PARADE SQUARE.

I MUST THEREFORE STATE THAT I HAVE NO IDEA WHAT PURPOSE THIS PECULIAR "ADVANCED PORTICOÖID" SERVED.

### ARTIFACTS

PRINCE HENRY BASTION IS NOT A PARTICULARLY PRODUCTIVE AREA FOR ARTIFACTS. IN THE FILL ABOVE THE CASEMATE, THE MOST NOTEWORTHY FIND WAS RANDOMLY DISTRIBUTED ROUND SHOT OF ALL SIZES, AT VARIOUS ELEVATIONS.

THE CASEMATE ITSELF WAS RATHER MORE INTERESTING IN ITS ARTIFACTS, AS SHOULD BE EXPECTED. AT THE ENTRANCE TO THE CASEMATE, WE FOUND SEVERAL HUNDRED SMALL GLASS TRADE BEADS: LIGHT AND DARK BLUE, WITH SOME RED, CLEAR, AND GREEN. OPPOSITE, AT THE TIP OF THE CASEMATE ON THE FLOOR, WE FOUND A LEATHER MOCASSIN, WHICH COULD BE THE SOURCE OF THESE BEADS, AND A BROKEN WINE BOTTLE.

AS WELL, WE FOUND AN ANVIL, SEVERAL GUN FLINTS, AND FIVE BARRELS, TWO OF WHICH WERE FULL OF A WHITE PUTTY-LIKE SUBSTANCE WHICH TASTES LIKE CALCIUM AND WHICH HAS BEEN TENTATIVELY IDENTIFIED AS WELDING FLUX. THE SIDES OF THESE LATTER TWO BARRELS HAD DISAPPEARED, BUT THE BOTTOM REMAINED AND THE CONTENTS RETAINED VAGUE BARREL SHAPES. AS WELL,

SEVERAL LARGE, UNIDENTIFIABLE IRON OBJECTS WERE FOUND AND, AT THE ENTRANCE, ODD SIZED LEAD SHOT VARYING FROM LARGE MUSKET SIZE TO NO LARGER THAN THE GLASS BEADS. THE CALIBRE VARIETY OF THIS SHOT WAS SO GREAT THAT IT APPEARED MORE LIKE WASTERS THAN LIKE DELIBERATELY MADE, USEABLE AMMUNITION.

THESE ARTIFACTS GIVE THE IMPRESSION THAT THE CASEMATE WAS USED AS A BLACKSMITH SHOP, WHERE DROP SHOT WAS MADE AND GENERAL METAL WORK WAS DONE. IN ANY CASE, NOTHING WAS FOUND TO CONTRADICT THIS THEORY.

SINCE THE CASEMATE WAS REPORTEDLY COMPLETED IN 1753 AND CONDEMNED BY THE BRITISH IN 1755, THE AREA BENEATH THE ROOF PROBABLY CONSTITUTES AN ENCAPSULATED OCCUPATION ZONE WHICH IS EXCLUSIVELY FRENCH AND WHICH IS LIMITED TO TWO YEARS DURATION. THE BRITISH MAY HAVE USED THE CASEMATE, BUT DOCUMENTARY SOURCES IN THIS CASE DO NOT CLARIFY THE SITUATION, AND TO DATE NO DEFINITELY BRITISH ARTIFACTS HAVE BEEN FOUND. THEREFORE ALL ARTIFACTS FROM THE CASEMATE (SUB-OPERATION 2E13K) MAY BE USEFUL FOR CROSS-DATING AND IDENTIFICATION PURPOSES. UNFORTUNATELY ONLY A FEW SHERDS OF BOTTLE GLASS AND ALMOST NO CERAMICS WERE FOUND, ALTHOUGH FURTHER EXCAVATION MAY PRODUCE MORE OF BOTH.

REVETMENT

AT THE NORTHWEST CORNER OF THE CASEMATE WE ENCOUNTERED A STONE REVETMENT WHICH WARRANTS MENTION. THE WALL CONSISTED OF THREE COURSES OF UNCUT STONE, IN A VERY BAD STATE OF REPAIR. THE EXPOSED PORTION OF THE WALL (FIVE FEET LONG, MAXIMUM TWO FEET WIDE) WAS COMPLETELY DESTROYED BY THE BACKHOE.

THIS WALL, WHOSE TOP WAS AT 131.0' A.S.L., LED AT AN ANGLE FROM THE ENTRANCE TO THE BRITISH CASEMATE. IT PROBABLY SERVED TO CONTAIN THE CURTAIN WALL BETWEEN THIS CASEMATE AND PRINCE HENRY BASTION, AND IS UNDOUBTEDLY CONTEMPORARY TO THE BRITISH CASEMATE (1757). IT WAS FOUND SO CLOSE TO THE CORNER OF THE FRENCH CASEMATE, IN FACT ALMOST SUPER-IMPOSED ON IT, THAT ITS CONSTRUCTION MAY HAVE BEEN INSTRUMENTAL IN THE COMPLETE DECLINE OF THE WOODEN BUILDING.

LITTLE OF THIS WALL WAS EXPOSED IN 1966, SO DESPITE ITS PARTIAL DESTRUCTION, I ASSUME THAT THE REST REMAINS INTACT FOR FUTURE STUDY.

BRICK PLATFORM

IN THE MIDDLE OF PRINCE HENRY BASTION'S TERREPLEIN, IMMEDIATELY BELOW SOD LEVEL AT AN ELEVATION OF 133.9' A.S.L., WE EXPOSED A PLATFORM OF BRICKS LAID ON EDGE WITHOUT MORTAR (OR WITHOUT ANY MORTAR REMAINING: THE EARTH AROUND THE BRICKS HAD DECAYED MORTAR IN IT, WHICH MAY OR MAY NOT RELATE TO THE PLATFORM), SIMILAR TO THE WALK/DRAIN IN 2E16. THE STRUCTURE COVERED AN AREA ROUGHLY 9' X 8.5', ORIENTED NORTHWEST TO SOUTHEAST. MOST OF THE BRICKS APPEAR TO BE MISSING, AS THE STRUCTURE WAS UNDOUBTEDLY A FULL RECTANGLE ORIGINALLY.

ALL I CAN DO HERE IS REFER THE READER TO FIGURE 2, P. 21, WHICH IS A PLAN OF THE FEATURE. I HAVE NO IDEA WHAT PURPOSE THE CREATION SERVED, OR WHEN IT WAS BUILT. NO DATABLE ARTIFACTS WERE ASSOCIATED WITH IT. PROBABLY IT IS POST-MILITARY IN ORIGIN; POSSIBLY IT IS RELATED TO THE SITE'S BEING MADE A NATIONAL HISTORIC PARK IN 1926, OR POSSIBLY IT DATES TO THE ROCK-GARDEN PERIOD OF OPERATION 2E17, ALTHOUGH IN THE LATTER CASE THE BRICKS ARE LAID FACE DOWN RATHER THAN ON EDGE.

IT REMAINS ONE OF MANY ENIGMAS.



2E13 BRICK PLATFORM

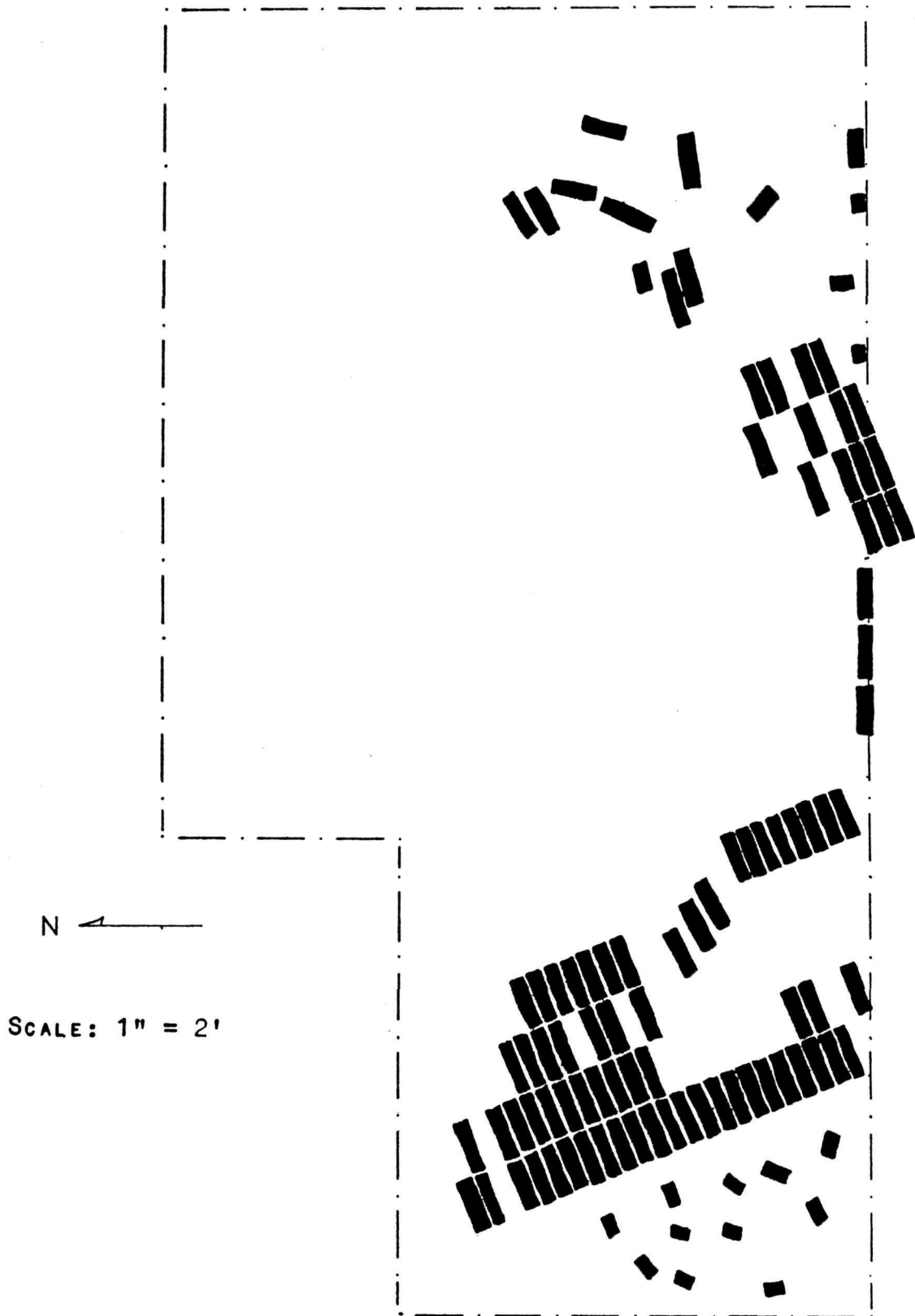

FIG. 2

## OPERATION 2E16. THE MEN'S BARRACKS

[FOR PRECISE HORIZONTAL MEASUREMENTS IN ALL CASES SEE DRAWING 7, APPENDIX II.]

PRIOR TO EXCAVATION, THE MEN'S BARRACKS APPEARED AS A LONG, NARROW,  $2\frac{1}{2}$ ' DEEP DEPRESSION EXTENDING ALONG THE PARADE SQUARE ADJACENT AND PARALLEL TO THE CURTAIN JOINING PRINCE HENRY AND PRINCE FREDERICK BASTIONS.

OUR EXCAVATIONS, CONSISTING BASICALLY OF 16 SUB-OPERATIONS, COMPLETELY EXPOSED AN AREA 88' NORTH-SOUTH BY 30' EAST-WEST. ONE SUBSIDIARY SUB-OPERATION SERVED TO TRACE AN EXTERNAL FEATURE.

VERTICALLY, EXCAVATION EXTENDED IN GENERAL TO THE TOP OF THE FIRST COMPLETE FEATURES FOUND, A MAXIMUM 4' B.S. ONE SMALL TRENCH CUT THROUGH THE LEVEL OF THE UPPERMOST FLOOR, BUT NO OTHER FEATURES--WALLS, FIREPLACES, ETC.--WERE DISSECTED OR EVEN DISTURBED. STERILE SOIL WAS NOT REACHED, NOR DO WE YET HAVE ANY IDEA OF THE VERTICAL EXTENT OF FEATURES OR OF THE NUMBER OF POSSIBLE EARLIER OCCUPATION LEVELS. IN THIS WAY WE REVEALED NOT ONLY FOUNDATIONS, BUT THE COMPLETE BASEMENT FLOOR OF THE BUILDING.

THE BARRACKS IS 71' LONG BY 17.5' WIDE (INSIDE MEASURE), ORIENTED NORTH-SOUTH. IT IS SURROUNDED BY A REGULAR BUT DISTURBED RED BRICK WALK/DRAIN COMPLEX, WITH A BRICK DRAIN

2E16 OPERATION PLAN

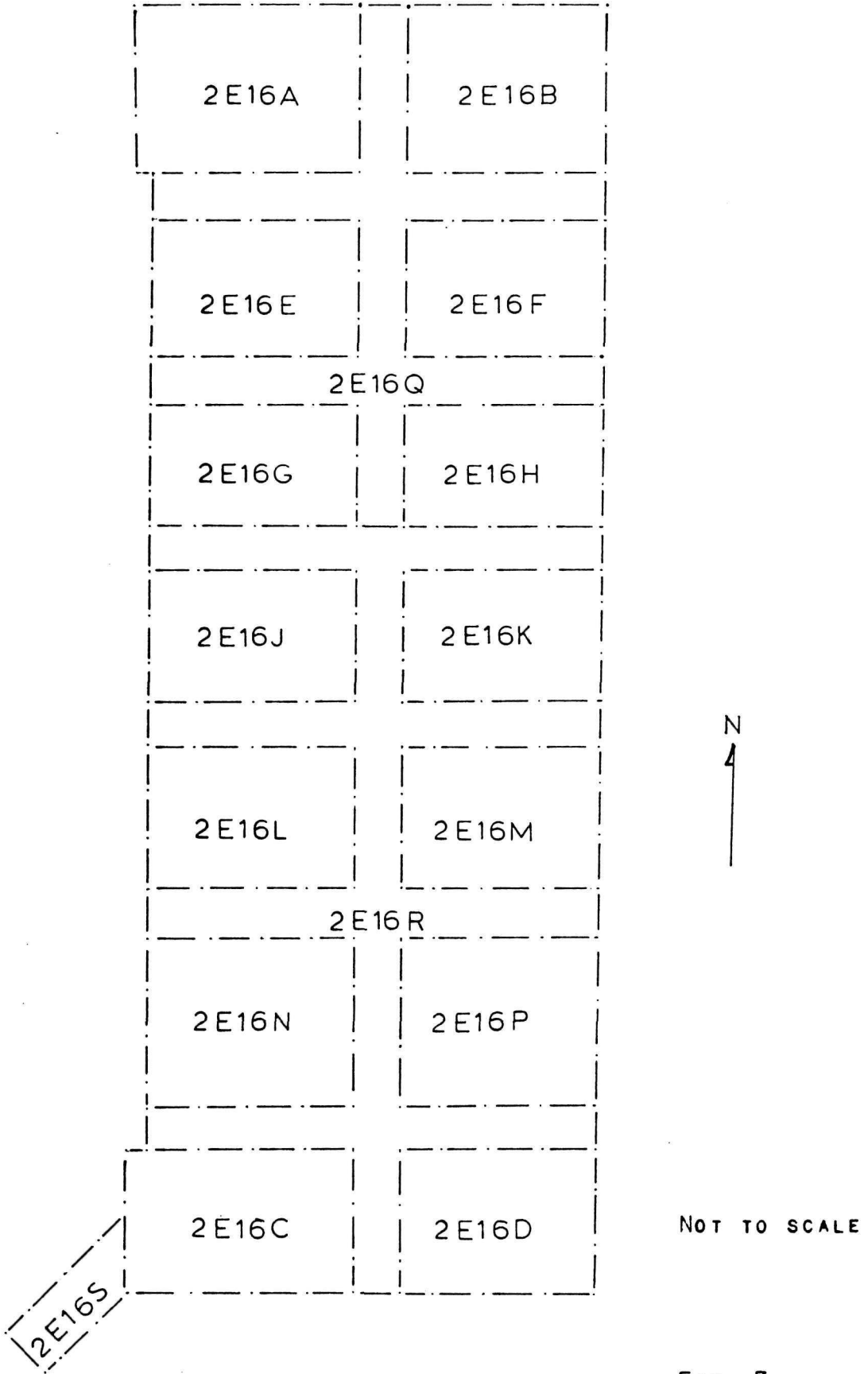
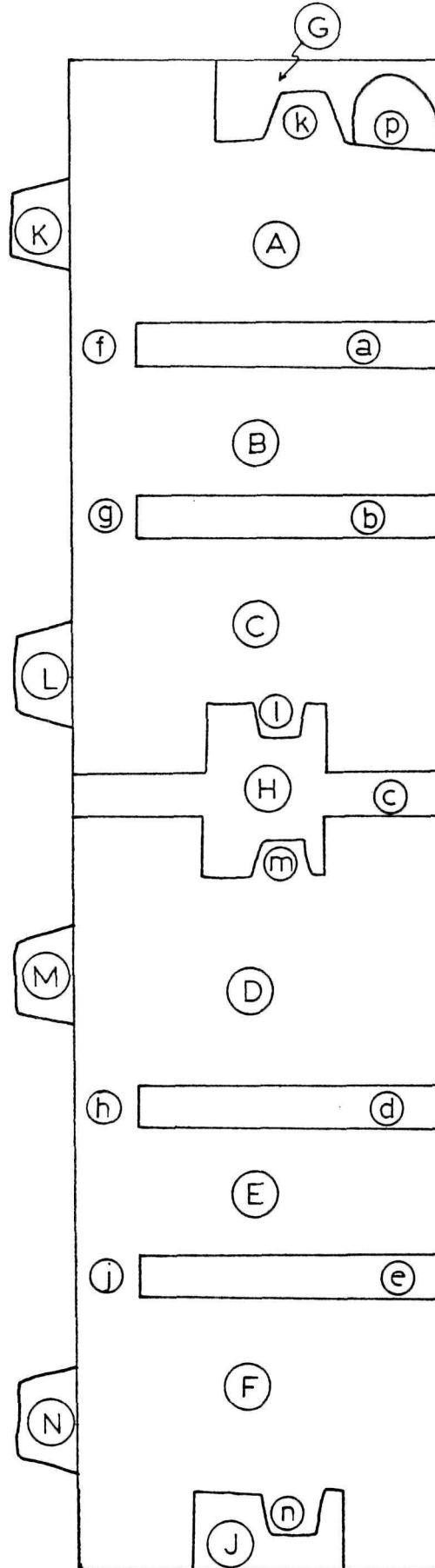

FIG. 3

2E16 RELATIVE LOCATION OF STRUCTURES

KEY

- (A) ROOM 1
- (B) ROOM 2
- (C) ROOM 3
- (D) ROOM 4
- (E) ROOM 5
- (F) ROOM 6
- (G) NORTH FIREPLACE
- (H) CENTRAL FIREPLACE
- (J) SOUTH FIREPLACE
- (K) WINDOW 1
- (L) WINDOW 2
- (M) WINDOW 3
- (N) WINDOW 4
- (a) PARTITION 1
- (b) PARTITION 2
- (c) PARTITION 3
- (d) PARTITION 4
- (e) PARTITION 5
- (f) DOOR 1
- (g) DOOR 2
- (h) DOOR 3
- (j) DOOR 4
- (k) HEARTH 1
- (l) HEARTH 2
- (m) HEARTH 3
- (n) HEARTH 4
- (p) OVEN



NOT TO SCALE

FIG. 4

LEADING FROM THE SOUTHWEST CORNER TOWARDS THE BRITISH ENTRANCE TO THE FORT. INSIDE, FIVE PARTITION WALLS (FOUR WITH DOORWAYS) DIVIDE IT INTO TWO SETS OF THREE ADJOINING ROOMS. IT IS ILLUMINATED BY FOUR WINDOWS ON THE WEST SIDE, AND HEATED BY THREE FIREPLACES. PARTS OF A WELL-MADE WOODEN FLOOR REMAIN.

NO TRACE OF ENTRANCES WAS FOUND, SO WE MUST ASSUME THAT ACCESS TO THE BASEMENT WAS BY WOODEN STAIRCASES FROM INSIDE THE FIRST STOREY.

#### BRICK DRAIN

IMMEDIATELY BENEATH SURFACE, I.E.  $4\frac{1}{2}$  TO 5' ABOVE THE LEVEL OF THE UPPERMOST WOODEN FLOOR, IS A RED BRICK COMPLEX WHICH ALMOST SURROUNDS THE BARRACKS. IT CONSISTS OF ONE LAYER OF BRICKS, PLACED ON EDGE AND ALIGNED WITH THE BUILDING WALLS, BOUNDED ON THE OUTSIDE BY A SINGLE ROW OF BRICKS LEANING LENGTHWISE AGAINST THE OTHERS. AT THE CORNERS OF THE BUILDING THE BRICKS ARE INTERLOCKED INTO A HERRINGBONE PATTERN.

AT THE SOUTHWEST CORNER THESE BRICKS LEAD INTO A SHALLOW, 3' WIDE DRAIN, OF WHICH WE EXPOSED 14' [SEE PLATE 17, APPENDIX I]. THE DRAIN IS CONSTRUCTED THE SAME AS THE MAIN PART OF THE FEATURE, EXCEPT THAT IT IS EDGED ON BOTH SIDES.

THROUGHOUT, THESE BRICKS ARE BADLY DISTURBED. THE EAST SIDE

ESPECIALLY HAS SLIPPED IN OVER THE BUILDING WALLS AND INTO THE BASEMENT, PROBABLY BECAUSE OF DIFFERENTIAL THAWING EACH SPRING ON THE STEEPLY SLOPING INSIDE FACE OF THE CURTAIN. HOWEVER, THE PATTERN AND APPROXIMATE DISTRIBUTION CAN STILL BE OBSERVED.

ON THE NORTH, WEST, AND SOUTH SIDES THE BRICKS COVER AN AREA ROUGHLY FIVE FEET WIDE. ON THE NORTH AND SOUTH SIDES THEY EXTEND OUT 6' FROM THE INSIDE OF THE BUILDING WALLS, WHILE ON THE WEST SIDE THEY EXTEND OUT AN ADDITIONAL TWO FEET. THEY ARE DISCONTINUOUS, AND THE WIDTH OF THE FEATURE VARIES CONSIDERABLY, AS DRAWING 7, APPENDIX II, SHOWS.

ON THE EAST SIDE, THE NORTH HALF OF THE BRICK FEATURE IS COMPLETELY MISSING IF IT EVER DID EXIST, WHILE WHAT REMAINS OF THE SOUTH HALF IS AT BEST 4' WIDE, GENERALLY STOPPING ONLY 3' FROM THE INSIDE OF THE BUILDING WALL.

IT IS REASONABLE TO ASSUME THAT THIS FEATURE IS A DRAINAGE SYSTEM, DESIGNED TO CONDUCT WATER FROM EAVES OR ROOF GUTTERS OUT OF THE FORT. IN BETTER-PRESERVED SECTIONS, SUCH AS THE SOUTHWEST CORNER, THE OUTSIDE PORTION RETAINS A SLIGHT TROUGH-SHAPE. THE CONTOURS OF THE FEATURE HAVE ALTERED SO GREATLY THAT THE MAGNITUDE AND DIRECTION OF SLOPE IS IMPOSSIBLE TO DETERMINE. CONSIDER, FOR EXAMPLE, THE WEST SIDE: IN 2E16E, THE MAXIMUM ELEVATION IS 126.1' A.S.L. TWELVE FEET SOUTH, IN 2E16G, IT IS 123.9'. ELEVEN FEET

SOUTH OF THAT, 2E16J IS 125.9'. ANOTHER ELEVEN FEET SOUTH, IN 2E16L, IT IS 125.7'. FROM THERE IT IS BETTER PRESERVED, RETURNING IN 2E16C TO 126.1' A.S.L.

PROBABLY THE BRICKS ORIGINALLY CONSTITUTED A FIRM, FLAT STRUCTURE AT LEAST 5' WIDE. SINCE THEY ARE SET ON EDGE, THEY WERE PROBABLY DESIGNED TO SUPPORT MORE THAN THE WEIGHT OF WATER, SO I CONCLUDE THAT THE INNER PORTION (I.E. CLOSE TO THE BUILDING) FORMED A SIDEWALK PROTECTED BY OVERHANGING EAVES, WHILE THE OUTER PORTION WAS ORIGINALLY TROUGH-SHAPED AND FORMED THE DRAIN PER SE.

THAT PART OF IT WHICH IS UNQUESTIONABLY DRAIN, THE SOUTHWEST PROJECTION, CONTAINED HUGE QUANTITIES OF SMALL NAILS. THIS MAY BE INCIDENTAL, OR IT MAY INDICATE THAT PARTS, AT LEAST, OF THE DRAIN WERE COVERED WITH WOOD. NO TRACE OF WOOD WAS FOUND, AND THE NUMBER OF NAILS WAS RATHER EXTREME FOR THIS EXPLANATION, BUT ONE CAN SEE THAT SUCH A COVER WOULD HAVE BEEN AN ADMIRABLE REFINEMENT.

THE DRAIN SLOPES FROM 126.0' A.S.L. AT THE NORTHEAST END TO 125.6' A.S.L. AT THE SOUTHWEST END. FOURTEEN FEET FROM THE SOUTHWEST CORNER OF THE BUILDING, THE DRAIN HAD BEEN ABRUPTLY CUT OFF. THREE FEET BEYOND THIS CUT IT HAD NOT YET REAPPEARED, ALTHOUGH BEYOND THIS A DISTINCT DEPRESSION IN THE SOD, WHICH MAY INDICATE THE CONTINUATION OF THE DRAIN, IS VISIBLE. PRESUMABLY THIS DISTURBANCE IS A RECENT OCCUR-

RENCE, AS IT SEEMS UNLIKELY THAT SUCH A WELL-BUILT DRAIN WOULD SIMPLY STOP, BUT AS THE DRAIN LIES IN THE TOPSOIL NO STRATIGRAPHIC EVIDENCE COULD BE FOUND TO EXPLAIN THE PHENOMENON.

ON THE EAST SIDE, AN ADDITIONAL FEATURE, IN THE FORM OF LINES OF DRY-LAID FIELD STONE, WAS FOUND. FOR A DISCUSSION OF THAT ON THE NORTH HALF OF THE WALL, SEE MR. TRUDEL'S REPORT. THE SOUTH HALF, WHICH IS NOT AS WELL BUILT AS THE NORTH HALF, COULD CONCEIVABLY BE PART OF A REVETMENT TO PREVENT CURTAIN SLUMP INTO OR AGAINST THE BUILDING, OR PART OF A RAMP TO GUN PLATFORMS ON THE CURTAIN, BUT IS MORE PROBABLY AN IMPOVERISHED "TEMPORARY" SUBSTITUTE FOR THE OBLIQUE BRICK BORDER WHICH, THOUGH FOUND ELSEWHERE ALONG THE WALK/DRAIN, DOES NOT APPEAR HERE.

WITH NO EVIDENCE TO SUPPORT THE ASSUMPTION, I SUSPECT THAT THE BUILDERS SIMPLY RAN OUT OF BRICKS BEFORE THE WALK/DRAIN WAS FINISHED, AND MADE DO AS BEST THEY COULD ON THOSE PARTS OF IT WHICH WERE NOT FREQUENTED. IF THE ROOF HAD GUTTERS EMPTYING AT THE CORNERS, THREE SIDES TO THE DRAIN WOULD BE FUNCTIONALLY ADEQUATE, THE FOURTH COMPLETING A GESTALT BUT BEING OTHERWISE REDUNDANT.

### WALLS

ALTHOUGH WE DID NOT EXPOSE THE OUTSIDE OF THE MAIN WALLS, THEY APPEAR IN PLAN VIEW TO BE TWO FEET WIDE. THEY ARE OF



MORTARED FIELD STONE SET IN REGULAR COURSES AND ROUGHLY FACED ON THE INSIDE. WE FOUND AT MOST FIVE COURSES (APPROXIMATELY 3.8' HIGH IN THE CORNERS, MAXIMUM ELEVATION 124.6' A.S.L.) AND MORE COMMONLY TWO COURSES (AVERAGE 1.5' HIGH, 122.3' A.S.L.) OF STONE REMAINING ABOVE FLOOR LEVEL [SEE PLATE 15, APPENDIX 1]. ORIGINALLY THE FOUNDATIONS WERE UNDOUBTEDLY HIGHER: SUFFICIENTLY SO, IN FACT, TO ACCOUNT FOR SOME 69 CUBIC YARDS OF STONE RUBBLE AND MORTAR WHICH COVERED THE ENTIRE FLOOR OF THE BARRACKS TO AN AVERAGE DEPTH OF  $1\frac{1}{2}$  FEET.

ALL THE WALLS HAD APPARENTLY COLLAPSED INWARD.

INSIDE THE BASEMENT ARE FIVE EAST-WEST PARTITION WALLS, BUILT THE SAME AS THE MAIN WALLS, AND ALL 2' WIDE. MR. TRUDEL REPORTS ON PARTITIONS 1 AND 2. PARTITION 3, THE CENTRAL ONE, IS CONTINUOUS FROM THE WEST WALL TO THE EAST WALL, AND IS APPARENTLY BONDED TO THEM WITH THE STONES OF THE VARIOUS WALLS INTERLOCKING. PARTITIONS 1, 2, 4 AND 5 ARE EACH 13' LONG, STARTING AT THE EAST WALL BUT STOPPING SHORT OF THE WEST WALL TO FORM DOORWAYS. PARTITION 4 HAS ALMOST COMPLETELY DISAPPEARED, AND EXISTS IN THE FORM OF A FEW RANDOM STONES BETWEEN ABRUPTLY CUT-OFF BEAMS AND FLOORBOARDS. PARTITION 5 NOW STOPS 1.4' WEST OF THE EAST WALL: THAT THE DISAPPEARANCE OF THESE STONES IN NO WAY HARMED THE EAST WALL INDICATES BUTTING RATHER THAN BONDING, AND SHOWS THAT PARTITION 5 WAS BUILT LATER THAN THE MAIN WALLS.

PARTITION 3 HAS TWO TO THREE COURSES OF STONE REMAINING, STANDING A MAXIMUM 2.2' ABOVE FLOOR LEVEL. IT IS EDGED BY A BASEBOARD ON THE NORTH SIDE.

PARTITION 5 ON THE OTHER HAND IS ONLY ONE COURSE HIGH, 0.5' ABOVE FLOOR LEVEL, AND IS NOT EDGED BY BASEBOARD.

THESE PARTITIONS DIVIDE THE BASEMENT INTO 6 ROOMS. ROOMS 1, 3, 4 AND 6 ARE APPROXIMATELY 12.5' WIDE (NORTH-SOUTH), WHILE ROOMS 2 AND 5 ARE ONLY 6' WIDE. ALL ARE, OF COURSE, 17.5' LONG (EAST-WEST).

ROOMS 1, 3, 4 AND 6 WERE EITHER LIVING OR WORKING ROOMS. THEY ARE LARGE, AND ALL CONTAIN HEARTHES AND WINDOWS. ROOMS 2 AND 5, HOWEVER, ARE SMALL, DARK AND COLD. I PROPOSE THAT THESE LATTER WERE STORE ROOMS. (ROOM 5 CONTAINED AT LEAST SIX SHOE SOLES. POSSIBLY QUARTERMASTER STORES WERE KEPT HERE.) ROOM 1 WAS A KITCHEN, BEYOND DOUBT: AS WELL AS A HEARTH, IT CONTAINS WHAT CAN ONLY BE INTERPRETED AS A BREAD OVEN OF THE TYPE IN USE AT UPPER CANADA VILLAGE. THIS IS GENERALLY A ROUND, RAISED, CHIMNEYLESS OVEN WITH A METAL DOOR, LOCATED BESIDE A HEARTH. HOT COALS ARE SHOVELLED FROM THE HEARTH TO THE OVEN TO HEAT IT, THEN SCRAPED OUT (HENCE THE BRICK FLOOR IN FRONT OF THE OVEN IN ROOM 1, AND THE LARGE QUANTITY OF COAL CLINKERS AND ASH FOUND WEST OF THE FIREPLACE) WHEN THE OVEN IS HOT, AND REPLACED BY THE BREAD TO BE BAKED. OR, IT CAN HAVE A CHIMNEY, IN WHICH CASE

THE FIRE IS KINDLED IN THE OVEN RATHER THAN CARRIED FROM THE ADJACENT HEARTH.

### DOORS

OF THE DOORWAYS AT THE WEST END OF PARTITIONS 1, 2, 4 AND 5 VERY LITTLE REMAINS. THE PARTITIONS STOP APPROXIMATELY 4.5' FROM THE WEST WALL. 3.3' OF FLOORING CONTINUES WEST OF THE PARTITIONS, AND STOPS AT RAISED STONE PLATFORMS AVERAGING 1.2' EAST-WEST BY 2' NORTH-SOUTH, SET AGAINST THE BUILDING WALL. THE TOP OF THE PLATFORM OF DOOR 3 WAS RAISED A MAXIMUM 1.15' ABOVE FLOOR LEVEL, WHILE THAT OF DOOR 4 WAS A MAXIMUM 1.0' ABOVE FLOOR LEVEL.

AGAINST THE EAST FACES OF THESE STONE PLATFORMS, ON THE SOUTH HALF OF DOORS 1 AND 3 AND THE NORTH HALF OF DOORS 2 AND 4, ARE THE REMAINS OF 0.3' X 0.6' UPRIGHT BEAMS [SEE FIGURE 5 ON P. 32, PLATE 14, APPENDIX I, AND DRAWING 7, APPENDIX II].

PRESUMABLY THE WEST SIDE OF THE DOORWAYS WAS THE HINGED SIDE, AND THE PLATFORMS AND BEAMS COMPRISED THE MAIN PORTION OF THE DOOR FRAME. THE LOCATION OF THE UPRIGHTS INDICATES THAT DOORS 1 AND 3 WOULD SWING TO THE SOUTH, AND DOORS 2 AND 4 WOULD SWING TO THE NORTH, SO THAT ALL DOORS OPENED INTO THE STORE ROOMS (ROOMS 2 AND 5), THUS CONSERVING SPACE IN THE MORE FREQUENTED ROOMS 1, 3, 4 AND 6.

2E16 DOORWAY

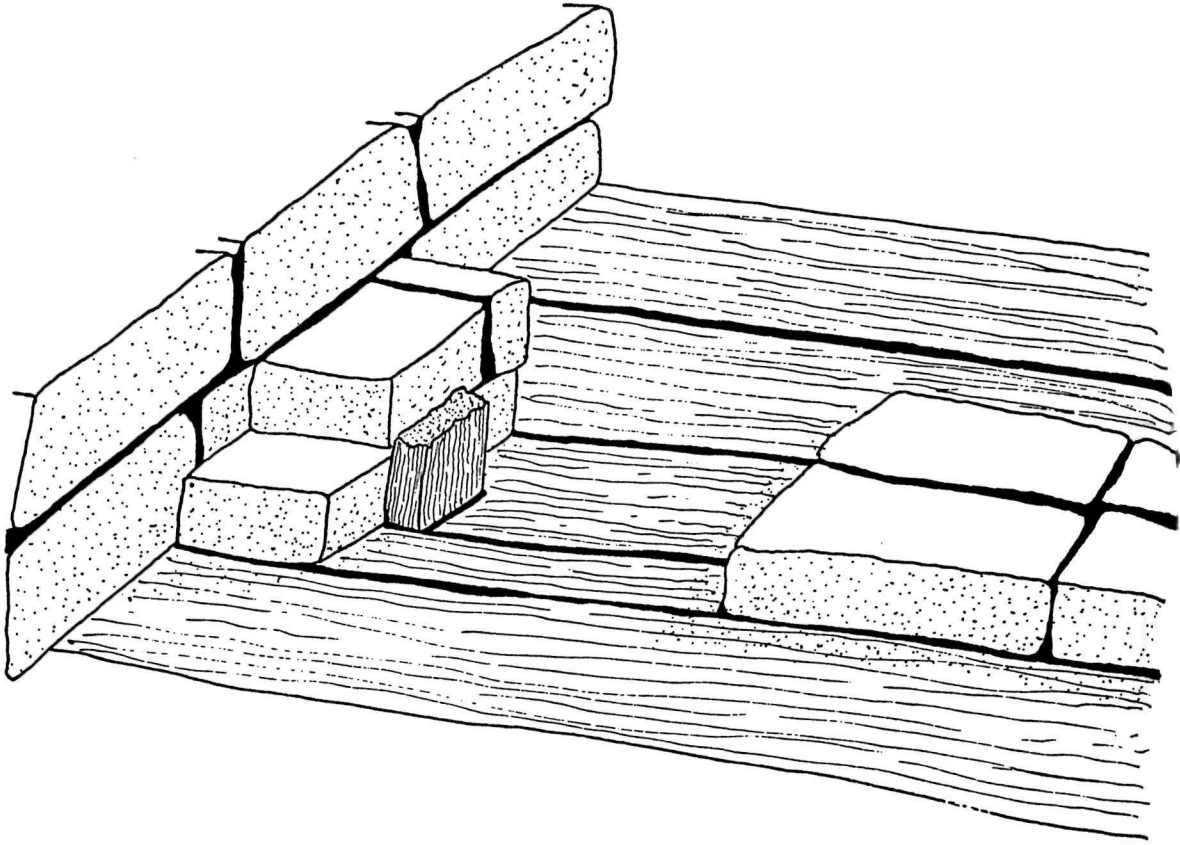

DOOR 3 ALONE PRESENTED AN ADDITIONAL FEATURE. 2.6' EAST OF THE UPRIGHT WAS A RECTANGULAR MORTISE FOR A STUD MEASURING 0.35' EAST-WEST BY 0.25' NORTH-SOUTH. NO PART OF THE UPRIGHT BEAM REMAINED. THIS MAY HAVE BEEN THE LOCATION OF THE EAST HALF OF THE DOOR FRAME. HOWEVER, NO OTHER DOORWAY HAD THIS FEATURE.

### FLOOR

THE FLOOR OF THE BARRACKS IS A BOARD-AND-SLEEPER FEATURE IN VARYING STATES OF PRESERVATION. WHEN IT WAS EXPOSED, THE FLOOR WAS FOUND TO BE IN EXCELLENT CONDITION IN SOME PLACES; IN OTHERS, THE BOARDS WERE BADLY BROKEN AND ROTTED. IN STILL OTHER AREAS, ESPECIALLY AT THE SOUTH END OF THE BUILDING, THE BOARDS HAD COMPLETELY DISAPPEARED ALTHOUGH THE SLEEPERS REMAINED INTACT, WHICH SUGGESTS LOOTING RATHER THAN DISINTEGRATION.

THE SLEEPER BEAMS WERE SQUARED 4" X 6" 'S, SET ON EDGE ON THE EARTH, APPARENTLY WITHOUT STONE OR BRICK SUPPORTS. THEY RAN NORTH-SOUTH, WHICH IS THE LONG AXIS OF THE BUILDING BUT THE SHORT AXIS OF EACH ROOM IN THE BASEMENT. THUS THE SPANS WERE FROM 6' TO 12.5' (DEPENDING ON THE ROOM), STOPPING AT WALLS AND OVERLAPPING AT DOORWAYS. THERE WERE ABOUT SIX PER ROOM, RATHER IRREGULARLY SPACED AND SELDOM PERFECTLY PARALLEL TO EACH OTHER.

LYING ON THESE SLEEPERS WERE BOARDS ORIENTED EAST-WEST. THESE AVERAGED 0.1' THICK, WERE AT MOST 12' LONG, AND VARIED BETWEEN 0.7' AND 1.4' WIDE WITH AN AVERAGE WIDTH OF 0.95'. THEY WERE ATTACHED TO THE SLEEPERS WITH  $2\frac{1}{4}$ " SQUARE IRON NAILS WITH ROUND HEADS MEASURING 0.05' IN DIAMETER. IDEALLY THERE WERE TWO NAILS PER BOARD PER SLEEPER; WHERE SIGNS OF ONLY ONE REMAIN, IT IS NEVER CENTERED ON THE BOARD. MANY OF THE NAILS HAVE DISAPPEARED, AND ALL ARE BADLY CORRODED.

THE ELEVATION OF THE TOP OF THIS FLOOR AVERAGED 120.8' A.S.L.

SOME BASEBOARD WAS FOUND INTACT [SEE FIGURE 6, P. 35].

APPARENTLY THE FOUR MAIN WALLS AND THE CENTRAL PARTITION AT LEAST WERE EDGED BY BASEBOARD, IF NOT ALL WALLS AND FIREPLACES.

THE BASEBOARD HAD BEEN SET ON EDGE AGAINST THE WALLS AND NAILED TO THE FLOOR. IT IS AT BEST 0.39' WIDE BY 0.04' THICK, ALTHOUGH IN MOST CASES IT IS SO POORLY PRESERVED THAT THE ORIGINAL DIMENSIONS CAN NOT BE DETERMINED [SEE PLATE 16, APPENDIX I].

SOUTH OF THE CENTRAL FIREPLACE WE DUG A SMALL TRENCH AND FOUND A SECOND, EARLIER FLOOR AT AN ELEVATION OF 120.1' A.S.L. THE WOOD WAS VERY WELL PRESERVED, BUT MUCH OF IT HAD APPARENTLY BEEN REMOVED (WHICH IS UNDOUBTEDLY WHY THE TOP FLOOR WAS BUILT.)

IN THE SECOND FLOOR, THE ORIENTATION OF BEAMS AND SLEEPERS IS EXACTLY OPPOSITE TO THAT OF THE LATER FLOOR, WITH SLEEPERS

2E16 FLOOR AND BASEBOARD

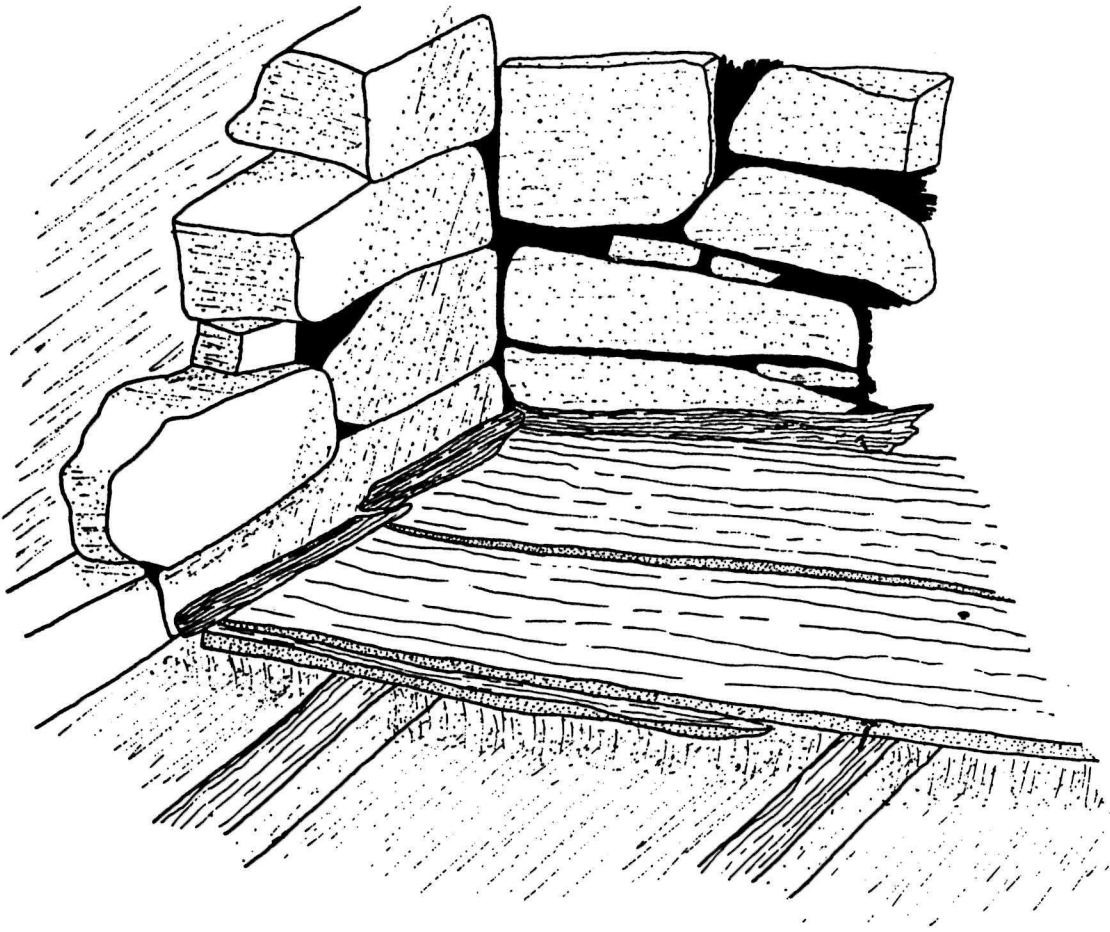

FIG. 6

RUNNING EAST-WEST AND BOARDS GOING NORTH-SOUTH. THIS IS UNUSUAL BECAUSE BEAMS ARE ALMOST ALWAYS SET TO SPAN THE LEAST PRACTICAL DISTANCE BETWEEN SUPPORTS: THE EAST-WEST ORIENTATION HERE SUGGESTS EITHER THE PRESENCE OF A CENTRAL SUPPORTING SILL BENEATH IT, OR THE ABSENCE OF INTERIOR PARTITIONS AT THE TIME IT WAS BUILT (OR POSSIBLY BOTH).

IN THAT SMALL AREA WE DID EXPOSE, THE WOOD USED WAS APPROXIMATELY THE SAME DIMENSIONS AS THE WOOD OF THE LATER FLOOR. NO NAILS WERE FOUND. THE FLOOR PER SE STARTED 3' IN FROM THE MAIN WALL OF THE BARRACKS, AND WAS EDGED BY LARGE FLAT STONES, SIMILAR TO THE EXPOSED FLOOR LEVEL IN 2E17.

SO LITTLE WAS EXCAVATED THAT NO CONCLUSIONS CAN YET BE DRAWN ABOUT THIS EARLIER FLOOR.

#### WINDOWS

ON THE WEST SIDE OF THE BARRACKS, JUST BELOW THE PRESENT SOD LEVEL, ARE FOUR "WINDOWS". THESE ARE SQUARE BOX-LIKE STRUCTURES WITH STONE SIDES AND INWARD SLOPING BRICK BOTTOMS, PROJECTING OUT FROM THE MIDDLE OF THE MAIN BUILDING WALL TO THE INSIDE EDGE OF THE BRICK WALK [SEE PLATE 13, APPENDIX I].

DIMENSIONS AND DESCRIPTIONS OF THE WINDOWS ARE GIVEN IN FIGURE 7, P. 37.

ORIGINALLY THESE WINDOWS WERE PROBABLY ALL THE SAME. ALL



## 2E16 WINDOWS

WINDOW	SLOPE	WIDTH AT BACK	WIDTH AT FRONT	DEPTH AT SOUTH	DEPTH AT NORTH	NUMBER OF COURSES
1	21°	3.5'	3.7'	2.9'	2.0'	1
2	20.5°	4.0'	3.8'	2.0'	2.1'	1
3	22°	2.9'	2.75'	2.3'	2.05'	2 AT BACK
4	24°	3.3'	3.3'	1.85'	2.4'	2

WINDOW	HEIGHT AT BACK	HEIGHT AT SOUTH	HEIGHT AT NORTH	ELEVATIONS FRONT	A.S.L. BACK
1	0.65'	0.8'	0.9'	123.4'	124.3'
2	0.7'	0.95'	0.95'	123.6'	124.3'
3	1.0'	0.3'	1.2'	123.1'	123.9'
4	1.3'	1.5'	1.2'	123.3'	124.15'

FIG. 7

MEASURED APPROXIMATELY 3.5' WIDE (NORTH-SOUTH) AND 2.5' DEEP (EAST-WEST), WITH A SLOPE OF ABOUT  $15^{\circ}$  TOWARDS THE INSIDE (ALTHOUGH NOW THE SLOPE IS MORE LIKE  $20^{\circ}$ ). THE SIDES WOULD HAVE BEEN THREE COURSES HIGH, ENOUGH TO RAISE THE OUTSIDE EDGE ABOVE THE LEVEL OF THE WALK, SO THAT WATER WOULD NOT RUN IN. IN THE CENTER OF THE MAIN WALL OF THE BUILDING THE GLASS WOULD HAVE BEEN SET, FRAMED BY STONE. THE STONE FOUNDATIONS OF THE BUILDING WOULD PROBABLY RISE AT LEAST TO THE TOP OF THESE WINDOWS, AND THE FRAME PORTION OF THE BARRACKS WOULD BE SET ABOVE THAT.

THIS IS OF COURSE PURELY HYPOTHETICAL. IN FACT THE EVIDENCE SUPPORTING THE ABOVE RECONSTRUCTION IS AS NEBULOUS AS FOLLOWS:

I ASSUME THAT THE STRUCTURES ARE WINDOWS BY VIRTUE OF THEIR LOCATION IN RELATION BOTH TO THE ROOMS AND TO THE FLOOR (THE LOWER EDGE AVERAGES 2.7' ABOVE THE WOODEN FLOOR). ALSO, BESIDES HAVING THE GENERAL APPEARANCE OF WINDOWS, THERE ARE TOO MANY OF THEM TO BE DOORS, AS FOUR DOORS ON ONE SIDE OF A BUILDING ARE NOT ONLY UNNECESSARY BUT CREATE AN INSULATION PROBLEM IN WINTER, AND THEY DO NOT APPEAR TO LEAD TO STAIRWAYS OR OTHER STRUCTURES, WHICH DOORS AT THAT ELEVATION WOULD HAVE TO DO.

THE DIMENSIONS ARE AN AVERAGE OF EXISTING DIMENSIONS.

THE SLOPE IS INFERRED FROM SIMILAR BASEMENT WINDOWS I HAVE SEEN, WITH CONSIDERATION OF THE AMOUNT THE WALL AND WALK

HAVE SLUMPED IN.

THAT SIDES EXISTED AT ALL MEANS DRAINAGE WAS A PROBLEM, SO SIDES WOULD HAVE HAD TO BE HIGHER THAN THE BRICK WALK, HENCE HIGHER THAN THEY NOW ARE.

NO EVIDENCE REMAINS TO PROVE THAT THE WINDOWS EVER HAD GLASS.

THE STONE FRAME AND THE HEIGHT OF THE WALLS ARE SUGGESTED BY THE AMOUNT OF STONE RUBBLE FOUND INSIDE THE BASEMENT. IF THE BUILDING WAS NOT COMPLETELY OF STONE (THE HISTORIC RECORDS STATE THAT IT WAS NOT), IT AT LEAST HAD HIGHER FOUNDATIONS THAN NOW REMAIN, HIGHER EVEN THAN THE BOTTOM OF THE WINDOWS (123.5' A.S.L.). STRUCTURALLY IT WOULD NOT BE REASONABLE TO HAVE THE WINDOWS FRAMED HALF IN STONE AND HALF IN WOOD, AND AS WOOD AND GLASS WOULD NOT ADEQUATELY SUPPORT A COMPLETELY STONE FRAME, THE FOUNDATIONS SHOULD HAVE EXTENDED TO THE TOP OF THE WINDOWS AT LEAST.

EACH WINDOW IS LOCATED IN LINE WITH THE FRONT OF A HEARTH. IT COULD BE SIGNIFICANT THAT WINDOW 3, THE NARROWEST AND MOST DAMAGED WINDOW, IS ALIGNED WITH THE SOUTH HEARTH OF THE CENTRAL FIREPLACE (HEARTH 3) WHICH IS THE WORST OR MOST DISTURBED OF THE FOUR HEARTHS. WAS THIS AREA, ROOM 4, SUBJECT TO MORE STRESS THAN THE OTHERS SINCE ABANDONMENT, OR WAS IT SIMPLY, FOR SOME REASON, POORLY BUILT?

FIREPLACES

THE MEN'S BARRACKS CONTAINED THREE FIREPLACES, WITH A TOTAL OF FOUR HEARTHES AND ONE OVEN. MR. TRUDEL REPORTS ON THE NORTH FIREPLACE, WITH HEARTH 1 AND THE OVEN. MY CONCERN IS WITH THE CENTRAL AND SOUTH FIREPLACES, HEARTHES 2, 3 AND 4.

THE SOUTH FIREPLACE CONSISTS OF A BRICK HEARTH (#4) AND BRICK OVER STONE BACK, EDGED BY TRAPEZOIDAL CUT STONES [SEE PLATE 8, APPENDIX I]. AGAINST THE FRONT, OUT OF PLACE, WAS FOUND A LARGE CUT STONE ENGRAVED:

"CR 14 [OR G?] \*R + 1778 W"

ABOVE SHALLOWER ETCHINGS OF TWO HORSE OUTLINES. PRESUMABLY THE STONE WAS A MANTEL, OR POSSIBLY A PLAQUE SET IN THE CHIMNEY ABOVE THE MANTEL [SEE FIGURE 8, P. 41]. THE MEANING OF THIS INSCRIPTION HAS NOT YET BEEN DETERMINED, BUT A POSSIBLE INTERPRETATION IS:

CR WOULD PROBABLY BE THE INITIALS OF THE PERSON WHO DID THE INSCRIPTION, OR ONE OF HIS FELLOWS.

14\*R WOULD MEAN "FOURTEENTH REGIMENT" (POSSIBLY "OF HORSE", CAVALRY, OR HORSE ARTILLERY). OR, IF IT IS G\*R, IT WOULD PROBABLY STAND FOR GEORGE REX.

T IS, OF COURSE, "IN THE YEAR OF OUR LORD".

1778 OBVIOUSLY IS A DATE, AND COULD BE EITHER THE DATE OF THE INSCRIPTION OR THE DATE OF ARRIVAL OF THE GROUP IN CANADA OR AT THE FORT.

W IS ANOTHER PERSON'S INITIAL.

2E16 Mantel Stone

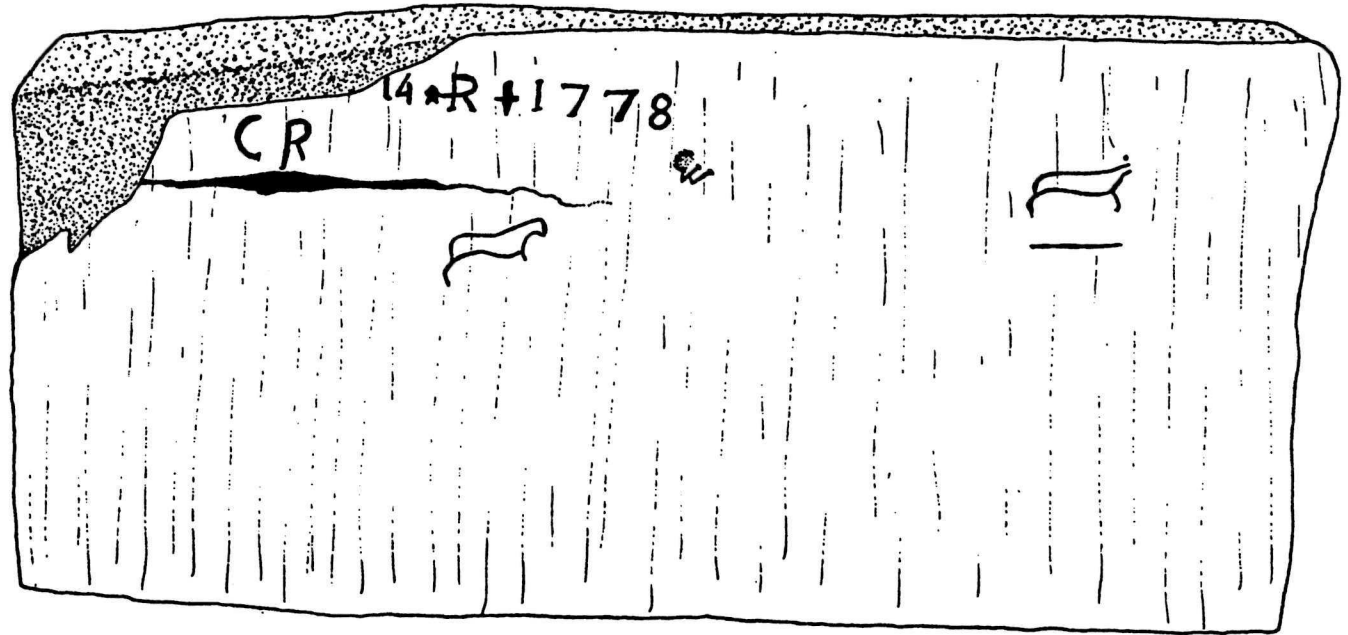

41

FIG. 8

WITHIN 15' OF THE FIREPLACE, PART OF A CHIMNEY STONE WAS ALSO FOUND--A SQUARE STONE WITH A CIRCULAR PORTION OF THE CENTER CUT OUT. THE STONE IS EDGED IN A WAY WHICH INDICATES THAT IT SAT AT THE TOP OF THE CHIMNEY, SO WE HAVE NO DEFINITE INDICATION WHETHER THE CHIMNEY ITSELF WAS OF BRICK OR OF STONE [SEE FIGURE 9, P. 43]. STONE RUBBLE SOUTH OF THE SOUTH WALL OF THE BARRACKS TESTIFIES FOR THE LATTER POSSIBILITY, WHILE A HEAVY CONCENTRATION OF BROKEN BRICKS NORTHWEST OF THE FIREPLACE STRONGLY POINTS TO THE FORMER.

THE FIREPLACE MEASURES 5.5' NORTH-SOUTH BY 8' EAST-WEST. THE HEARTH IS 3.3' WIDE AT THE BACK, FLARING TO 3.95' WIDE AT THE NORTH EDGE, 2.25' FROM THE BACK. THE BRICK FLOOR CONTINUES OUT APPROXIMATELY 4.5' FROM THE BACK, BUT I CONSIDER ONLY THE PORTION BETWEEN THE CUT STONE SIDES TO BE THE FIREBOX. AROUND THE BRICKS, THE WOODEN FLOOR HAS ALMOST COMPLETELY DISAPPEARED, SO THE EXACT LIMITS OF THE HEARTH ARE UNCERTAIN.

THE BACK AT PRESENT CONSISTS OF ONE COURSE OF STONES 0.6' HIGH, TOPPED BY THREE TO FIVE COURSES OF BRICKS SET FOR THE MOST PART END-ON, FACE DOWN. EACH COURSE OVERLAPS THAT BELOW IT, YIELDING AN INWARD SLANT LEADING TO THE DEFUNCT FLUE WHICH WOULD HAVE BEEN ROUGHLY OVER THE CENTER OF THE FIREBOX. MORTAR REMAINS BETWEEN THE BRICKS AND STONES (UNLIKE THE FLOOR, WHERE MORTAR HAS DISINTEGRATED), AND SOME BRICKS RETAIN SLIGHT TRACES OF BURNING.

## 2E16 CHIMNEY STONE

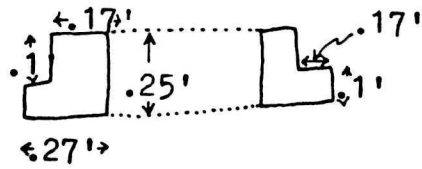
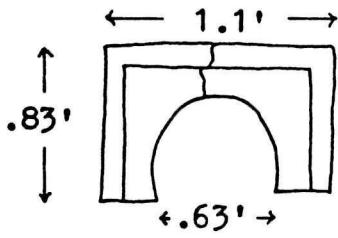
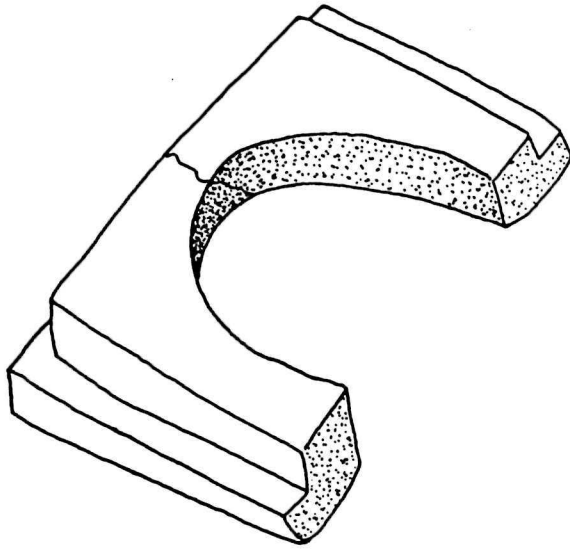

FIG. 9

THE SIDES, AS I HAVE SAID, CONSIST OF TRAPEZOIDALLY CUT STONES. THE WIDE END IS AT THE BACK, AND THE OUTSIDES ARE AT RIGHT ANGLES TO THE FRONT, RESULTING IN THE TRAPEZOIDAL SHAPE OF THE FIREBOX.

WEST OF THE HEARTH, AND APPARENTLY AN INTEGRAL PART OF THE FIREPLACE, IS A THICK, WELL-BUILT STONE WALL. THE WALL IS 3.75' WIDE (FROM THE LIP OF THE HEARTH), AND EXTENDS BACK TO THE SOUTH WALL OF THE BARRACKS WHERE IT FORMS A CORNER SIMILAR TO THE MAIN CORNERS OF THE BUILDING WALLS. ON THE NORTH SIDE IT IS EDGED BY BASEBOARD, BUT NOT ON THE WEST SIDE. VERTICALLY THE WALL IS INTACT FOR THREE COURSES, WITH A FOURTH DISTURBED-LOOKING COURSE ON TOP.

THE CENTRAL FIREPLACE IS NOT NEARLY AS WELL PRESERVED AS THE SOUTH ONE. ONLY ONE GOOD COURSE OF STONES REMAINS IN THE BODY OF THE STRUCTURE, AND THE WALLS OF BOTH HEARTHS HAVE BEEN VIRTUALLY REMOVED TO FLOOR LEVEL. THE FIREPLACE IS A 7.8' SQUARE ENLARGEMENT IN THE MIDDLE OF THE CENTRAL PARTITION [SEE DRAWING 7, APPENDIX II, AND PLATE 9, APPENDIX I]. VIRTUALLY NONE OF THE STONES FORMING IT ARE CUT, BUT MUCH MORTAR REMAINS AMONG THEM.

THE NORTH HEARTH OF THIS FIREPLACE (HEARTH 2), IS SIMILAR TO HEARTH 4. IT HAS A LARGE, HERRING-BONE PATTERNED BRICK FLOOR [BUT NO BRICKS REMAIN IN THE BACK: SEE PLATE 12, APPENDIX I], TRAPEZOIDAL IN SHAPE, WHICH PROJECTS NORTH FROM



THE SIDES OR "LIP" OF THE HEARTH APPROXIMATELY 2'. AT ITS OUTER EDGE, IT MEASURES 5.3' WIDE.

THE FIREBOX ITSELF MEASURES 2.8' WIDE AT THE BACK, AND AT ITS LIP TWO FEET NORTH OF THE BACK ATTAINS A WIDTH OF 4.0'. THE SIDES ARE TRAPEZOIDAL, LIKE THOSE OF HEARTH 4, BUT ONLY THE WEST SIDE STONE IS REALLY CUT: THE EAST SIDE IS ROUGHLY SHAPED.

THE WEST WALL OF THE HEARTH AGAIN MANIFESTS THE SWELLING OBSERVED IN HEARTH 4, MEASURING 3' WIDE AT THE LIP AS COMPARED TO THE EAST WALL, 0.75' WIDE AT THE LIP.

THE NORTH EXTREME OF THE HEARTH LIES 5' FROM THE PARTITION TO WHICH IT IS JOINED. THE WHOLE NORTH SIDE OF THE FIREPLACE, INCLUDING THE ENTIRE HEARTH FLOOR, IS EDGED BY WOODEN FLOOR: IT IS BOXED IN BY BEAMS, AND THE FLOORBOARDS HAVE BEEN NEATLY TRIMMED AND ARE WELL-PRESERVED [SEE PLATE 11, APPENDIX 1].

THE SOUTH HEARTH OF THE CENTRAL FIREPLACE (HEARTH 3) IS ANOTHER MATTER, ALMOST COMPLETELY DIFFERENT FROM HEARTHS 1, 2 AND 4. IT IS BADLY PRESERVED, AND IN FACT APPEARS TO HAVE BEEN POORLY BUILT. NONE OF ITS STONES--NOT EVEN THE SIDE WALLS--ARE CUT, AND IF IT EVER HAD A BRICK FLOOR, THE ONLY TRACE OF IT IS ROUGH, RANDOM BRICK RUBBLE EMBEDDED IN THE EARTH [SEE PLATE 10, APPENDIX 1].

THE FIREBOX IS 3.1' WIDE AT THE BACK, AND 3.8' WIDE AT THE LIP. THIS APPEARS TO BE AN ACCIDENT OF THE PLACING OF SIDE STONES RATHER THAN A DELIBERATE ATTEMPT TO YIELD THE STANDARD TRAPEZOIDAL FLOOR. THE HEARTH IS 2.0' DEEP, AND DISPLAYS CONSIDERABLE EVIDENCE OF BURNING. ITS SOUTH EXTREME IS 2.8' FROM THE CENTRAL PARTITION.

THE HEARTH DOES RESEMBLE HEARTH 1, 2 AND 4 IN THAT ITS WEST WALL IS THICKER THAN ITS EAST WALL--2.9' AS COMPARED TO 1.0' ON THE EAST SIDE--BUT THE THICKER WEST PORTION IS NOT SOLID. WHAT IS APPARENTLY A SHIELD HAS BEEN BUILT UP AS AN AFTERTHOUGHT, AND IS SEPARATED FROM THE HEARTH WALL BY 0.3' RATHER THAN JOINED TO IT.

THE TOP STONE THAT REMAINS OF THE EAST SIDE HAS MOVED INTO THE FIREBOX: PLATE 10 SHOWS THIS IN ITS DISTURBED POSITION, THOUGH IT SHOULD REST DIRECTLY ON THE STONE SEEN IMMEDIATELY EAST OF IT AT A LOWER ELEVATION. SIMILARLY, ALL TRACES OF WOOD FLOOR NEAR IT HAVE DISAPPEARED, BUT FOR ONE SLEEPER BEAM. I CANNOT EXPLAIN WHY THIS HEARTH ALONE SHOULD HAVE BEEN FOUND IN SUCH A BAD STATE OF REPAIR, OR WHY IT SHOULD APPEAR TO HAVE BEEN BUILT LESS CAREFULLY THAN THE OTHER THREE.

#### ARTIFACTS

THE MEN'S BARRACKS WAS SO FULL OF ARTIFACTS, ESPECIALLY

POTTERY, THAT IT WOULD BE FUTILE AT THIS TIME TO ATTEMPT TO GIVE ANY SIGNIFICANT IMPRESSION OF THEIR NATURE OR DISTRIBUTION. SUFFICE TO SAY THAT A HASTY GLANCE INDICATES A PREPONDERANCE OF EARLY 19TH CENTURY ARTIFACTS, WHICH WOULD MEAN THAT THE EXPOSED FLOOR WAS BUILT OR OCCUPIED AROUND 1800.

ONE ODD SITUATION NEEDS TO BE MENTIONED, HOWEVER. AT THE SOUTH END OF THE BUILDING, AN ASH STRATUM WAS EXPOSED [STRATUM 4, DRAWING 8, APPENDIX II] WHICH CONTAINED CONTEMPORARY ARTIFACTS SUCH AS HEINZ KETCHUP BOTTLES AND COTTON SWEAT SHIRTS. THE STRATUM ABOVE THIS CONTAINED APPARENTLY 19TH CENTURY ARTIFACTS. THIS OF COURSE MUST MEAN THAT GARBAGE WAS RECENTLY DEPOSITED IN THE BARRACKS DEPRESSION, AND THE RESULTING UNSIGHTLY MESS WAS BURIED UNDER EARTH WHICH WAS MOST PROBABLY MOVED IN FROM ANOTHER PART OF THE SITE, OR AT LEAST FROM SOME PREVIOUSLY OCCUPIED AREA. IT MIGHT BE INTERESTING TO LEARN THE ORIGIN OF THIS FILL.

APPENDIX I

PLATES

PLATE 1. (66 x 367). 2E13A. THIS IS A VIEW OF THE DRY RUBBLE REVETTING ON THE ESCARP OF PRINCE HENRY BASTION AT THE SALIENT ANGLE, LOOKING FROM THE PARAPET EAST TOWARDS THE DITCH. THE REVETMENT IS PARALLEL TO THE LEFT FACE OF THE BASTION. THE DARK REDDISH BROWN STRATUM WHICH CONTAINS THE STONES HAS BEEN REMOVED TO A GREATER DEPTH THAN THE REST OF THE FLOOR--THUS THE OBLIQUE LINE OF EXCAVATION IN THE MIDDLE OF THE PICTURE. NO ARTIFACTS WERE FOUND WITHIN THIS STRATUM. NOTE THAT THE STONES ARE NOT CUT OR LAID IN COURSES: THEY LOOK MORE LIKE FILL OR RUBBLE THAN LIKE A DELIBERATE WALL. PRESUMABLY THE REVETMENT WAS HASTILY BUILT.

PLATE 2. (66 x 368). 2E13A. AGAIN, A VIEW FROM THE PARAPET OF PRINCE HENRY BASTION LOOKING EAST TOWARDS THE DITCH. THIS PHOTOGRAPH SHOWS THE PART OF THE SUB-OPERATION FLOOR WHICH IS CONCEALED IN PLATE 1. IN THE LOWER LEFT CORNER ARE SIX OF THE SEVEN HORIZONTAL POST HOLES MENTIONED IN THE TEXT: THEY ARE PARALLEL TO THE LEFT FACE OF THE BASTION, AND FORM ONE LAYER OF BONDING IN THE WOOD AND BEATEN EARTH STRUCTURE OF THE RAMPARTS. THE NORTH ARROW, WHICH IS THREE FEET LONG, SERVES AS A SCALE FOR THEM.



1



2

PLATE 3. (66 x 1058). 2E13K. THIS IS A TOTAL VIEW OF THE FRENCH CASEMATE IN PRINCE HENRY BASTION, FROM THE PARAPET LOOKING WEST TOWARDS THE PARADE SQUARE. MOST OF THE WOOD VISIBLE IS COLLAPSED ROOF: NOTE THAT, ALONG THE EDGES, VESTIGIAL SIGNS OF WALLS REMAIN. ALSO, IN THE RIGHT CENTER OF THE PICTURE, TWO OF THE THREE REMAINING UPRIGHTS ARE VISIBLE (INDICATED BY ARROWS).

THREE TRENCHES EXPOSING THE FLOOR CAN BE SEEN: IN THE FOREGROUND, WITH THE CENTER ROOF BEAM AND A COLLAPSED BARREL; IN THE MIDDLE BACKGROUND, WITH AN ANVIL, TWO BARRELS OF "FLUX", AND THE CENTER ROOF BEAM; AND BEFORE THE ENTRANCE IN THE BACKGROUND.

PLATE 4. (66 x 1059). 2E13K. HERE WE HAVE A DETAIL OF THE ENTRANCE TO THE FRENCH CASEMATE, LOOKING NORTHWEST FROM THE TERREPLEIN OF PRINCE HENRY BASTION. NOTE THE EXPOSED FLOOR OF THE CASEMATE, WITH ITS WELL-PRESERVED BOARDS AND NAILS, THE BEAM AND [NOW DISINTEGRATED] BOARD CONSTRUCTION OF THE ENTRANCE, AND THE PECULIAR STONE STRUCTURE LEADING AWAY FROM THE ENTRANCE. THE CENTER BEAM OF THE ROOF WAS NOT FOUND ON THE FLOOR AT THIS END OF THE BUILDING. BRICK RUBBLE IS SEEN IN THE UPPER LEFT CORNER OF THE PHOTOGRAPH.



3



4



PLATE 5. (66 x 849). 2E16. THIS VIEW, LOOKING SOUTH FROM PRINCE HENRY BASTION, SHOWS THE MEN'S BARRACKS NEAR THE MIDDLE OF EXCAVATION. THE 14 MAIN TRENCHES (SUB-OPERATIONS 2E16A TO 2E16P) HAVE BEEN OPENED, AND NO BALKS HAVE YET BEEN REMOVED. BEFORE COMPLETION, THE TRENCHES ON THE RIGHT WERE EXTENDED FOUR FEET WEST TO EXPOSE THE BRICKS, AND THOSE ON THE LEFT WERE EXTENDED THREE FEET EAST FOR THE SAME PURPOSE.

PLATE 6. (66 x 1043). 2E16. THE SAME VIEW AS PLATE 5, THIS PICTURE WAS TAKEN WHEN EXCAVATION IN THE MEN'S BARRACKS WAS COMPLETED BUT FOR THE TRACING OF THE DRAIN AT THE SOUTHWEST CORNER, AND THE CUT THROUGH THE FLOOR.

NOTE THE BRICK WALK, THE STONE REVETMENT ON THE LEFT, THE PARTITIONS, DOORWAYS (ON THE RIGHT), WINDOWS (ALSO ON THE RIGHT), AND TWO FIREPLACES--CENTRAL AND SOUTHERN.

5



6



PLATE 7. (66 x 1045). 2E16. THIS WAS TAKEN AT THE SAME TIME AS PLATE 6, BUT LOOKS NORTH TO THE MEN'S BARRACKS FROM PRINCE FREDERICK BASTION. THE SAME FEATURES ARE VISIBLE, EXCEPT THAT THIS VIEW SHOWS THE NORTH FIREPLACE AND OVEN AS WELL.

PLATE 8. (66 x 1018). 2E16. A CLOSE-UP OF THE SOUTH FIREPLACE (#4) OF THE MEN'S BARRACKS. IT SHOWS THE BACK AND FLOOR OF THE HEARTH, THE CUT STONE SIDES, THE WIDE WEST WALL OF THE FIREPLACE, AND THE RELATIONSHIP BETWEEN THE HEARTH AND THE WOODEN BASEMENT FLOOR.



7



8

PLATE 9. (66 x 1041). 2E16. THIS PHOTOGRAPH LOOKS WEST TO THE CENTRAL FIREPLACE OF THE MEN'S BARRACKS. BOTH HEARTHS ARE VISIBLE, AS IS THE DOORLESS CENTRAL PARTITION DIVIDING THE TWO MAIN PORTIONS OF THE BASEMENT.

NOTE AS WELL WINDOWS 3 (LEFT) AND 2 (RIGHT), ALIGNED WITH THE FRONTS OF HEARTHS 3 AND 2 RESPECTIVELY.

PLATE 10. (66 x 1016). 2E16. A CLOSE-UP OF THE SOUTH HEARTH (#3) OF THE CENTRAL FIREPLACE OF THE MEN'S BARRACKS. THIS HEARTH IS EXTREMELY POORLY PRESERVED. IT HAS NO FLOOR (THE BRICKS IN THE PHOTOGRAPH ARE APPARENTLY CHIMNEY RUBBLE), AND THE STONES ARE NOT WELL CUT. THE SIDE STONE ON THE RIGHT HAS SLIPPED OUT OF PLACE, AND SHOULD BE RESTING ON THE FLAT STONE BESIDE IT.

THE BACK OF THE HEARTH SHOWS MORE EVIDENCE OF BURNING THAN ANY OTHER HEARTH IN THE BARRACKS.

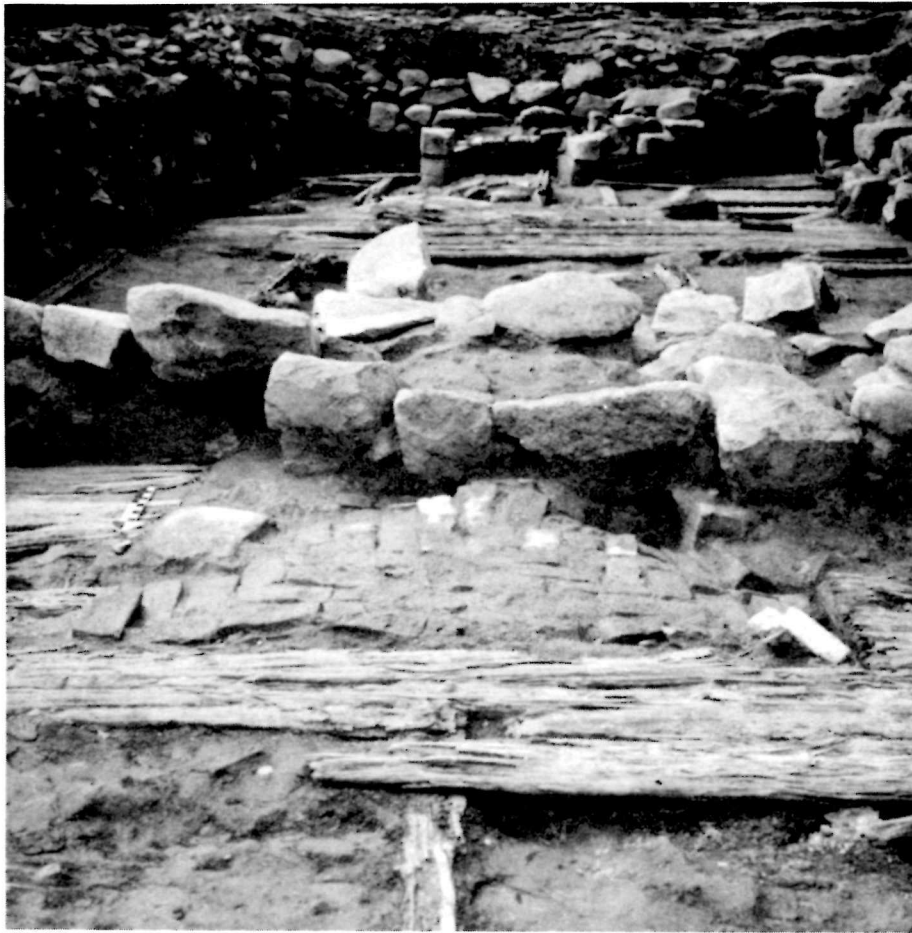

PLATE 11. (66 x 1013). 2E16. A CLOSE-UP OF THE NORTH HEARTH (#2) OF THE CENTRAL FIREPLACE OF THE MEN'S BARRACKS. THIS SCARCELY COMPARES WITH ITS COUNTERPART IN PLATE 10, HAVING A WELL PRESERVED BRICK FLOOR.

NOTE THE WAY THE WOODEN FLOOR IS BUILT AT THE EDGE OF THE HEARTH, BEING NEATLY SQUARED OFF.

PLATE 12. (66 x 1014). 2E16. THIS IS A DETAIL OF THE BRICK FLOOR OF THE NORTH HEARTH OF THE CENTRAL FIREPLACE (NORTHEAST CORNER--SEE PLATE 11). THE BRICKS INTERLOCK TO FORM A CORNER.

THE RESULTING "HERRINGBONE" APPEARANCE IS EVIDENT ON ALL HEARTH FLOORS, ON THE CORNERS OF THE BRICK WALK, AND ON A BRICK FLOOR SECTION EXPOSED IN 2E17, THE OFFICERS' BARRACKS. AS WELL AS BEING FUNCTIONALLY ADMIRABLE, IT IS AESTHETICALLY PLEASING.



11



12



PLATE 13. (66 x 1021). 2E16. A WINDOW. (THIS PARTICULAR ONE IS WINDOW 4.) NOTE THE SLOPING BRICK FLOOR, THE COURSED STONE SIDES, AND THE WAY THE BUILDING WALL APPEARS TO HAVE BEEN SQUARED OFF AROUND THE WINDOW.

VISIBLE AS WELL ARE THE WOODEN FLOOR AND THE BASE-BOARD.

PLATE 14. (66 x 1050). 2E16. A DOORWAY. (THIS IS DOOR 4.) THE STONE IN THE FOREGROUND IS THE END OF PARTITION 5. BEYOND IT IS THE STONE PROJECTION AND A WOODEN UPRIGHT, PRESUMABLY SUPPORTS AND FRAME FOR THE HINGED SIDE OF THE DOOR.

13



14



PLATE 15. (66 x 1020). 2E16. THIS IS A DETAIL OF A WELL PRESERVED PORTION OF THE WALL OF THE MEN'S BARRACKS: THE SOUTHWEST CORNER. FIVE GOOD COURSES CAN BE SEEN, ALTHOUGH THE TOP TWO HAVE SLIPPED IN A BIT. THE FLOOR IS WELL PRESERVED HERE, AND SOME BASEBOARD REMAINS.

PLATE 16. (66 x 971). 2E16. HERE IS A DETAIL OF BASEBOARD AND FLOOR IN THE SOUTHEAST CORNER OF THE MEN'S BARRACKS. THE BASEBOARD RETAINS ITS ORIGINAL POSITION RELATIVE TO THE FLOOR, AND ONE OF ITS NAILS IS VISIBLE (ON THE LEFT). THE TROWEL SERVES AS SCALE. THIS IS THE SUBJECT OF THE SKETCH, FIGURE 6, P. 35.



15



16

PLATE 17. (66 x 1047). 2E16. THIS IS THE BRICK DRAIN AT THE SOUTHWEST CORNER OF THE MEN'S BARRACKS, LEADING TOWARDS THE ENGLISH ENTRANCE TO THE FORT. NOTICE THAT THE BRICKS ARE SET ON EDGE, BOUNDED BY ROWS OF OBLIQUE BRICKS SET ON END, FORMING A SHALLOW TROUGH.

THE BACK EDGE OF THE EXCAVATION IS THE END OF THE DRAIN. AT THAT POINT THE DRAIN SEEMS TO HAVE BEEN CUT OFF, ALTHOUGH AS IT LIES IN THE TOPSOIL NO STRATIGRAPHIC EVIDENCE WAS FOUND TO PROVE THAT THIS HAS HAPPENED.



APPENDIX II

DRAWINGS

DRAWING 1

THIS IS A PLAN OF THE FLOOR OF SUB-OPERATION 2E13A. THE STRATA MARKED ARE AS FOLLOWS:

1. THE FILL OF THE BASTION. ACTUALLY, 1 ON THE LEFT CORRESPONDS TO STRATUM 8 IN DRAWINGS 2 AND 3, WHILE 1 ON THE RIGHT CORRESPONDS TO STRATUM 2 IN DRAWINGS 2 AND 3.
2. 5YR 3/4 DARK REDDISH BROWN SANDY CLAY. THIS CORRESPONDS TO STRATUM 10 IN DRAWING 3. IT IS THE STRATUM WHICH CONTAINS THE DRY STONE REVETMENT OF THE SALIENT ANGLE OF PRINCE HENRY BASTION.

THE SEVEN HORIZONTAL WOOD BONDING POST HOLES ARE SHOWN ON THE LEFT OF THE DRAWING.



2E13A

DRAWING 1

PLAN



0' 2' 4'

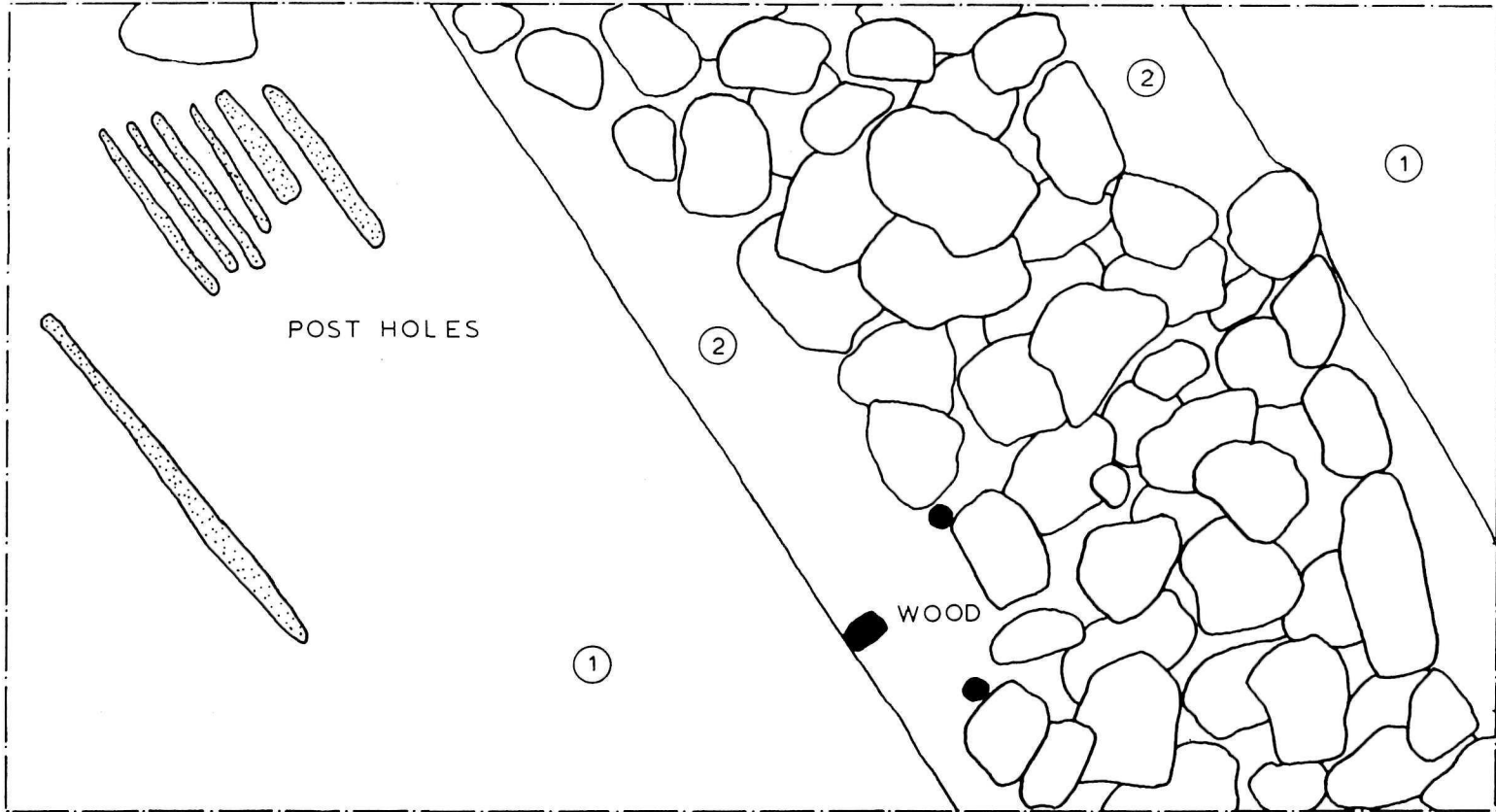

71

(2E-66-102-6)

DRAWING 2

THIS IS A CROSS-SECTION OF THE WEST FACE OF 2E13A, ILLUSTRATING THE STRATIGRAPHY LOOKING TOWARDS THE SALIENT ANGLE FROM THE DITCH. STRATIGRAPHY IS AS FOLLOWS:

1. 10YR 5/3 BROWN TOPSOIL, WITH MORTAR AND RED BRICK CHIPS (MAXIMUM DIAMETER 0.1').
  2. 5YR 3/4 DARK REDDISH BROWN TENDING TO DARK BROWN GRAVELLY LOAM (MAXIMUM DIAMETER OF GRAVEL 0.05'). THIS STRATUM COVERS OVER THE LAYERED FILL OF THE RAMPARTS, AND FROM ITS POSITION HERE AND IN DRAWING 3 I FEEL CONFIDENT THAT IF IT IS NOT POST-MILITARY IN ORIGIN, IT IS AT LEAST CONSIDERABLY MORE RECENT THAN ALL THOSE STRATA BENEATH IT, WHICH ARE VIRTUALLY CONTEMPORANEOUS TO EACH OTHER.
  3. 5YR 3/4 DARK REDDISH BROWN (APPEARING PINK) HARD GRAVELLY CLAY. MAXIMUM DIAMETER OF GRAVEL 0.15'.
  4. 5YR 3/4 DARK REDDISH BROWN (APPEARING GRAYER THAN 3 AND 5) LOAMY SAND, WITH SOME PEBBLES TO MAXIMUM DIAMETER 0.05'. RELATIVE TO STRATA 3 AND 5, THIS RESEMBLES SOD 11 (STRATUM 4) OF DRAWING 5.
  - 4A. BLACK SAND.
  - 4B. 10YR 3/2 VERY DARK GRAYISH BROWN CLAY, ORGANICALLY STAINED.
- 4A AND 4B ARE INCLUSIONS IN STRATUM 4.

5. 5YR 4/4 REDDISH BROWN HARD LOAMY CLAY WITH PEBBLES TO MAXIMUM DIAMETER 0.2'.
6. 7.5YR 4/4 DARK BROWN CLAYEY SAND WITH ROCKS TO 0.3' MAXIMUM DIAMETER. SOME CHARCOAL INCLUDED.
- 6A. 7.5YR 3/2 DARK BROWN CLAYEY SAND, ORGANICALLY STAINED. THIS APPEARS TO BE A SINGLE LOAD OF FILL DUMPED IN AT THE SAME TIME AS STRATUM 6.
7. 7.5YR 4/4 DARK BROWN SAND WITH ROCKS TO 0.3' MAXIMUM DIAMETER, LENSES OF GRAY SAND (EG. 7A) AND CARBON (DARKENED STREAKS).
8. MIXED FILL, PREDOMINATELY 7.5YR 4/4 DARK BROWN LOAMY SAND, WITH WOOD CHIPS AND POST HOLES (SHOWN AS BLACK AREAS) AND A FEW LARGE ROCKS. THE WOOD SHOWN HERE IS THE BONDING REFERRED TO IN THE TEXT.

DRAWING 2

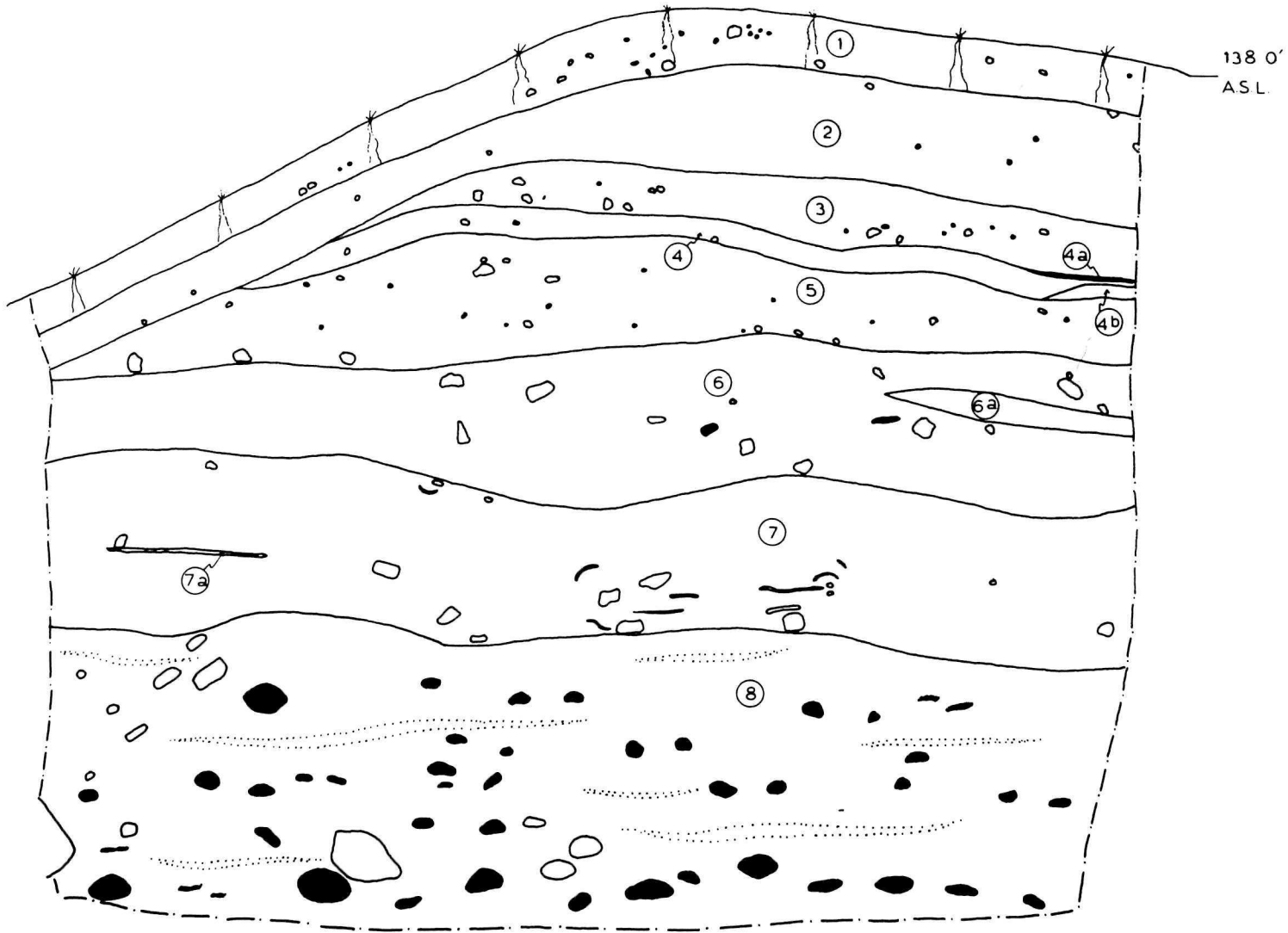

2E13 A

CROSS-SECTION

WEST FACE

75

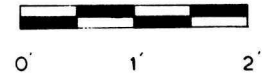

(2E-66-102-7)

DRAWING 3

THIS IS A CROSS-SECTION OF THE NORTH FACE OF 2E13A, BISECTING AND SHOWING THE SLOPE OF THE SALIENT ANGLE OF PRINCE HENRY BASTION. THE STRATA ARE THE SAME AS THOSE OF DRAWING 2, WITH TWO ADDITIONS:

9A. 2.5YR 5/4 REDDISH BROWN SAND.

9B. 5YR 4/1 DARK GRAY SAND. THESE ARE CONTEMPORARY TO STRATUM 2.

10. 5YR 3/4 DARK REDDISH BROWN SANDY CLAY. THIS IS THE STRATUM WHICH CONTAINS THE DRY STONE REVETMENT OF THE SALIENT ANGLE.

STRATA 1 AND 2 (PROBABLY INCLUDING 9) ARE MUCH MORE RECENT THAN THOSE BELOW, WHICH (2 TO 8, 10 INCLUSIVE) ARE APPARENTLY CONTEMPORANEOUS TO EACH OTHER.

THE SHARP DIVISION BETWEEN STRATUM 2 AND THE ENDS OF STRATA 3 TO 7 MARKS THE SLOPE OF THE ESCARP AT THE TIME OF THE BUILDING OF THE REVETMENT. STRATUM 8 LEVELS THE SLOPE OFF TO FORM WHAT HAS BEEN REFERRED TO AS THE BERM OR GUERITE PLATFORM, WHICH IS AUGMENTED BY THE BROAD TOP OF THE REVETMENT.

NOTE THAT THE WEST SIDE OF STRATUM 10, WHICH CONTAINS THE REVETMENT, SLOPES INTO THE ESCARP, RATHER THAN LYING ON IT AND SLOPING AWAY WITH IT.

DRAWING 3

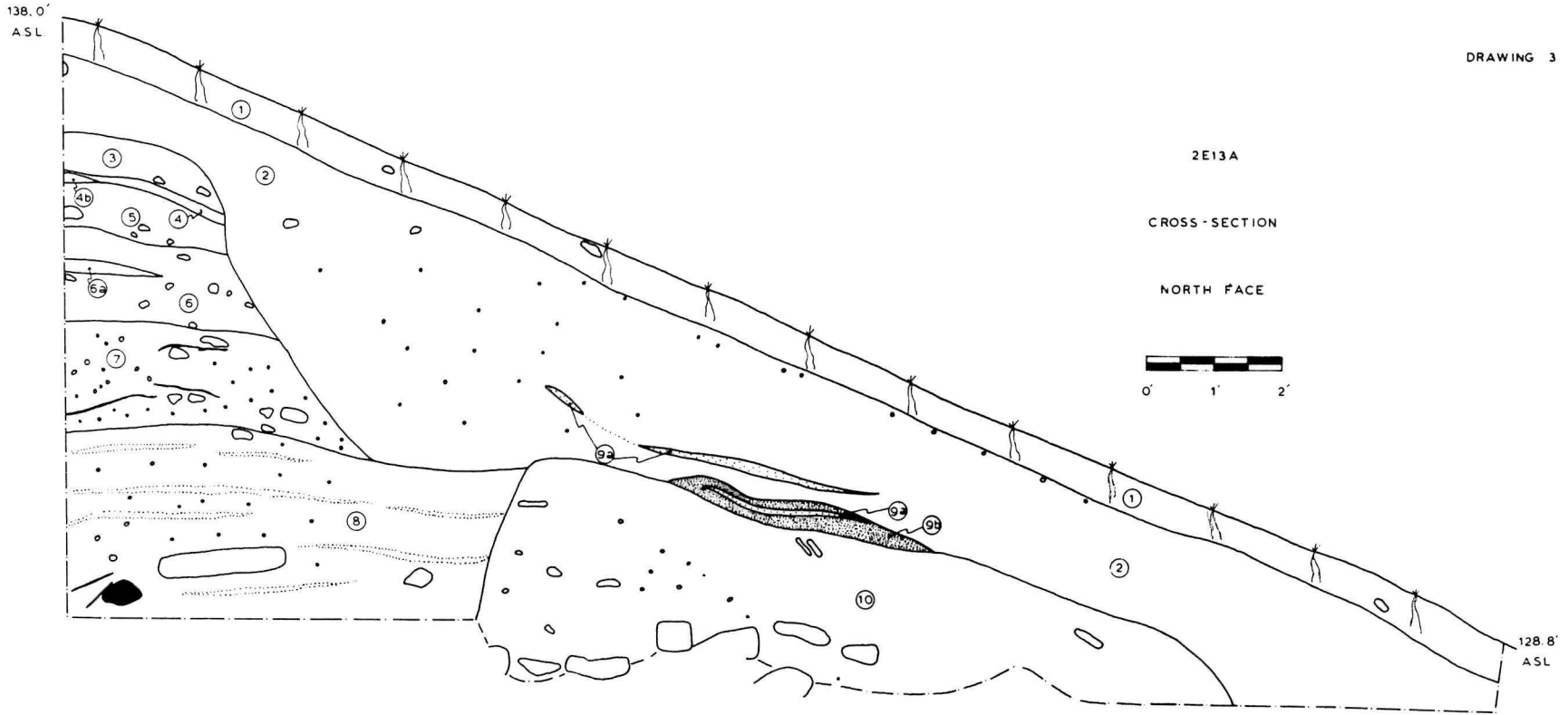

77

(2E-66-102-8)

DRAWING 4

THIS IS A PLAN OF THE FRENCH CASEMATE, SHOWING THE WOOD OF THE ROOF AND THE ENTRANCE. THE DRAWING, WITH ITS KEY, IS SELF-EXPLANATORY, SO NO COMMENT IS NEEDED HERE.



FORT BEAUSEJOUR, N.B. SITE 2E  
 PLAN OF CASEMATE ROOF  
 SUB-OPERATION 2E 13K

LEGEND	
○	CARRIER BELL
□	BRICK
●	BARREL
■	APPLY.
○	STONE
○	WOOD
■	UPRIGHT TRUSS
---	IMBIBITION FEATURE
---	LIST OF EXCAVATION



DRAWING 5

THIS IS A LONGITUDINAL CROSS-SECTION OF THE NORTH FACES OF 2E13G, D AND C, CUTTING EAST-WEST ACROSS THE TERREPLEIN OF PRINCE HENRY BASTION TO THE TOP OF THE FRENCH CASEMATE.

0' TO 25' COMPRISE SUB-OPERATION 2E13G.

25' TO 54' COMPRISE SUB-OPERATION 2E13D.

54' TO 83' COMPRISE SUB-OPERATION 2E13C.

STRATIGRAPHY IS AS FOLLOWS:

1. 7.5YR 4/2 DARK BROWN TOPSOIL, SOD III. NOTE THE PECULIAR LINES OF PEBBLES STARTING AT THE 3' AND 13' MARKS. THESE ARE UNDOUBTEDLY CAUSED BY SOME VARIETY OF FREEZE AND THAW PHENOMENA.
2. GRAY DISINTEGRATED MORTAR, WITH SOME RED BRICK CHIPS. 42' TO 49' MARKS THE EDGE OF THE BRICK PLATFORM DISCUSSED ON P. 20.
3. 7.5YR 4/4 DARK BROWN HARD LOAMY SAND WITH ROCKS TO 0.25' MAXIMUM DIAMETER.
4. 10YR 4/4 DARK YELLOWISH BROWN LOAMY SAND. THIS IS SOD II, PROBABLY ORIGINATING IN THE BRITISH OCCUPATION IN THE EARLY 1760'S, IMMEDIATELY AFTER THE CASEMATE COLLAPSE. INCLUDED IN THIS STRATUM (AND CONTEMPORARY TO IT) ARE:
  - 4A. 10YR 3/4 DARK YELLOWISH SAND.

- 4B. WHITE MORTAR.
- 4C. BLACK LOAM, ORGANICALLY STAINED.
5. 5YR 3/4 DARK REDDISH BROWN HARD CLAYEY SAND, WITH PEBBLES TO 0.15' MAXIMUM DIAMETER. THIS STRATUM MAY BE FILL OVER THE COLLAPSED CASEMATE BROUGHT IN BY THE BRITISH IN THE EARLY 1760'S.
- 5A. BLACK LOAM, ORGANICALLY STAINED.
6. 7.5YR 4/4 DARK BROWN LOAMY SAND. THIS STRATUM IS SOD 1, AND MOST PROBABLY ORIGINATED DURING THE FRENCH OCCUPATION, IMMEDIATELY AFTER THE CONSTRUCTION OF THE CASEMATE IN 1753. IT WAS ON TOP OF THIS STRATUM THAT THE ASH PIT AND THE SHELL DEPOSIT MENTIONED IN THE TEXT RESTED. DRAWING 6 DEMONSTRATES HOW THE STRATUM SAGGED IN WHEN THE CASEMATE COLLAPSED: ITS ORIGINAL ELEVATION, HENCE THE TERREPLEIN LEVEL DURING THE FRENCH OCCUPATION, HAS BEEN MASKED.
7. 5YR 3/4 DARK REDDISH BROWN HARD CLAYEY SAND, WITH ROCKS TO 0.3' MAXIMUM DIAMETER. THIS IS SOIL WHICH IS TYPICAL OF THE BEAUSEJOUR AREA, AND IS IN THIS CASE UNDOUBTEDLY FRENCH FILL OVER THE CASEMATE.
- 7A. GRAY CLAY.
8. ALL THREE AREAS MARKED 8 ARE BLACK LOAM, STAINS CAUSED BY HORIZONTAL BEAMS RELATED TO THE CONSTRUCTION OF THE CASEMATE.

9. THIS IS A DUMP LOAD OF "VARVED" SOIL POPULARLY REFERRED TO AS "MARSH MUD". THE VARVES ARE:

10YR 5/3 BROWN SAND

5YR 5/2 REDDISH GRAY CLAYEY SAND

5YR 6/1 LIGHT GRAY SAND.

IN SOME PLACES, BLACK CHARCOAL ALSO OCCURS. THE STRATUM IS PROBABLY FRENCH IN ORIGIN, AND ITS OCCURRENCE HERE, JUDGING FROM SIMILAR STRATA ELSEWHERE ON THE SITE, HAS NO MARKED SIGNIFICANCE.

10. 7.5YR 6/4 LIGHT BROWN VERY SANDY CLAY, WITH GRAVEL AND ROCKS TO 0.3' MAXIMUM DIAMETER. THIS STRATUM CLOSELY RESEMBLES SOD I AND II, AND MAY IN FACT HAVE BEEN SOD ORIGINALLY--IN WHICH CASE IT WOULD BE A CONTINUATION OF SOD I, WHICH WAS CUT OFF BY SOD II AT THE 51' MARK. IF THIS IS THE CASE, BETWEEN 62' AND 66.5', STRATUM 7 SHOULD MERGE WITH STRATUM 5 BELOW SOD II. AS STRATA 5 AND 7 ARE IDENTICAL IN COLOUR AND TEXTURE, HOWEVER, THE DIVIDING LINE IS NOT APPARENT.

STRATA 11 TO 15 INCLUSIVE PRE-DATE THE CONSTRUCTION OF THE CASEMATE, ARE FRENCH IN ORIGIN, AND ARE PART OF THE RAMPARTS.

11. 5YR 4/8 YELLOWISH RED LOAMY CLAY, WITH ROCKS AVERAGING 0.1' IN DIAMETER.

12. 5YR 4/8 YELLOWISH RED VERY HARD SANDY CLAY.

13. 2.5YR 3/4 DARK REDDISH BROWN LOAMY CLAY.

14. 5YR 4/4 DARK REDDISH BROWN CLAYEY LOAM.

15. 5YR 4/3 REDDISH BROWN SANDY CLAY.

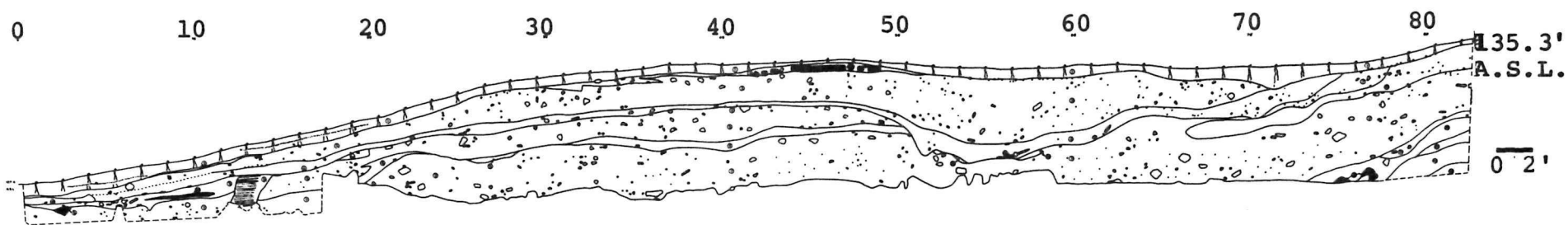

Drawing 5. 2E13G, D, C. Longitudinal Cross-Section (Looking North)

(2E-66-102-9)

DRAWING 6

THIS IS A TRANSVERSE CROSS-SECTION ACROSS THE SOUTH HALF OF THE CASEMATE, THE EAST FACE OF 2E13G. WHILE IT DOES NOT CONSTITUTE A COMPLETE TRANSVERSE CROSS-SECTION, IT ADEQUATELY DEMONSTRATES BOTH THE ORIGINAL STRATIGRAPHY SURROUNDING THE FRENCH CASEMATE AND THE STRATIGRAPHIC SEQUENCE OF CONSTRUCTION FOLLOWING ITS COLLAPSE.

STRATA 1, 2, 3, 4, 5, 6 AND 7 CORRESPOND TO THOSE WITH THE SAME NUMBERS IN DRAWING 5, AND ARE CONSIDERED IN THE DISCUSSION OF THAT DRAWING. NOTE HOWEVER THAT IN DRAWING 6, STRATUM 5 HAS INCLUSIONS OF 2.5Y 6/2 LIGHT BROWNISH GRAY CLAY (5A) WHICH DO NOT APPEAR IN DRAWING 5.

TO THE RIGHT OF (AND BELOW) THESE STRATA ARE FRENCH FILL LAYERS.

9. AS IN DRAWING 5, THIS IS A STRATUM OF VARVED "MARSH MUD".

I SUGGEST THAT THIS STRATUM ORIGINALLY LAY AT A HIGHER ELEVATION, BUT HAS SUNK DOWN INTO THE DEPRESSION CAUSED BY THE DISINTEGRATION OF THE CASEMATE WALLS.

10. 10YR 4/4 DARK YELLOWISH BROWN LOAMY SAND. LIKE STRATUM 10 IN DRAWING 5, THIS CLOSELY RESEMBLES SOD I AND II, AND MAY BE A CONTINUATION OF SOD I, STRATUM 6, WHICH WAS APPARENTLY BROKEN DURING THE CASEMATE COLLAPSE.

16. 10YR 4/4 DARK YELLOWISH BROWN LOAMY SAND WITH PEBBLES TO 0.05' MAXIMUM DIAMETER. LIKE STRATUM 9, THIS APPEARS

TO HAVE FALLEN INTO THE CASEMATE DEPRESSION. THERE IS, HOWEVER, ANOTHER POSSIBLE INTERPRETATION FOR THESE STRATA; IF THE CASEMATE WERE DUG INTO THE BASTION, RATHER THAN HAVING THE TERREPLEIN BUILT UP OVER IT, STRATA 16 AND 9 COULD BE FOUNDATION TRENCH FILL RATHER THAN COLLAPSE. THIS, HOWEVER, WOULD NOT ADEQUATELY EXPLAIN THE PRESENCE OF THE ASH PIT AND SHELL DEPOSIT WHICH RESTED ON STRATUM 6, NOR WOULD IT ALLOW FOR THE EXISTENCE OF A SOD STRATUM (#6) LYING IN THE MIDDLE OF THE FILL OVER THE CASEMATE.

17. 5YR 4/4 REDDISH BROWN LOAMY SAND, WITH PEBBLES TO 0.1' MAXIMUM DIAMETER.
18. 7.5YR 4/4 DARK BROWN LOAMY SAND, WITH PEBBLES TO 0.1' MAXIMUM DIAMETER. PRESUMABLY STRATA 17 AND 18 MET THE SAME FATE AS 9 AND 16, COLLAPSING WITH THE CASEMATE.
19. 7.5YR 4/4 DARK BROWN LOAMY SAND, WITH ROCKS TO 0.3' MAXIMUM DIAMETER. THIS IS THE LAST FRENCH FILL STRATUM OF THE TERREPLEIN. INCLUDED IN IT IS:
  - 17A. 10YR 7/1 LIGHT GRAY SAND, AND 10YR 3/4 DARK YELLOWISH BROWN SAND.
20. 5YR 4/4 REDDISH BROWN VERY HARD SLIGHTLY CLAYEY SAND, WITH PEBBLES TO 0.05' MAXIMUM DIAMETER.
21. 7.5YR 4/4 DARK BROWN LOAMY SAND. I BELIEVE THAT STRATA 20 AND 21 ARE SIMPLY DIFFERENT MANIFESTATIONS OF THE SAME

LAYER: THE TWO TOGETHER COMPRISE THE HIGHEST LEVEL OF PREDOMINATELY SANDY FILL WHICH IS UNDOUBTEDLY INTENDED AS DRAINAGE AWAY FROM THE CASEMATE.

22. SOFT MEDIUM SAND, OF VARIOUS COLOURS:

- A. 7.5YR 4/4 DARK BROWN.
- B. 5YR 3/4 DARK REDDISH BROWN.
- C. 5YR 4/2 DARK REDDISH GRAY.
- D. 10YR 6/2 LIGHT BROWNISH GRAY.
- E. 10YR 5/6 YELLOWISH BROWN.
- F. 5YR 4/4 REDDISH BROWN.
- G. 7.5YR 4/4 DARK BROWN.
- H. 5YR 3/4 DARK REDDISH BROWN.
- J. 10YR 5/3 BROWN.
- K. 7.5YR 3/2 DARK BROWN.

THIS SAND MUST BE SO LOCATED TO CONDUCT WATER AWAY FROM THE CASEMATE. SUB-SECTIONS J AND K IN PARTICULAR ARE RATHER UNUSUAL, IN THAT THEY APPEAR AS DESCENDING COLUMNS, WITH DIMENSIONS SIMILAR TO THOSE OF THE UPRIGHT BEAMS FOUND IN THE CASEMATE. THEY ARE NOT, HOWEVER, ORGANICALLY STAINED, AND ALTHOUGH K HAS WOOD CHIPS IN IT, THEY APPEAR TO HAVE MOVED INTO IT FROM THE CASEMATE RATHER THAN BEING THE REMAINS OF DISINTEGRATED BEAMS. THESE COLUMNS OF SAND MAY INDICATE THAT HOLES WERE DUG FOR BEAMS WHICH WERE THEN NOT INSERTED, OR THEY MAY INDICATE THAT BEAMS WERE REMOVED AND THE HOLES FILLED.



23. 10YR 3/4 DUSKY RED HARD SAND.
24. 5YR 3/4 DARK REDDISH BROWN VERY HARD SAND, WITH PEBBLES TO 0.2' MAXIMUM DIAMETER. STRATA 23 AND 24 MAY BE INCLUDED IN THE DRAINAGE STRATA AROUND THE CASEMATE, ALTHOUGH THEY ARE COMPACTED, AND ARE MORE LIKELY STANDARD SUB-STRATA FORMING THE BASIC STRUCTURE OF THE FORT.

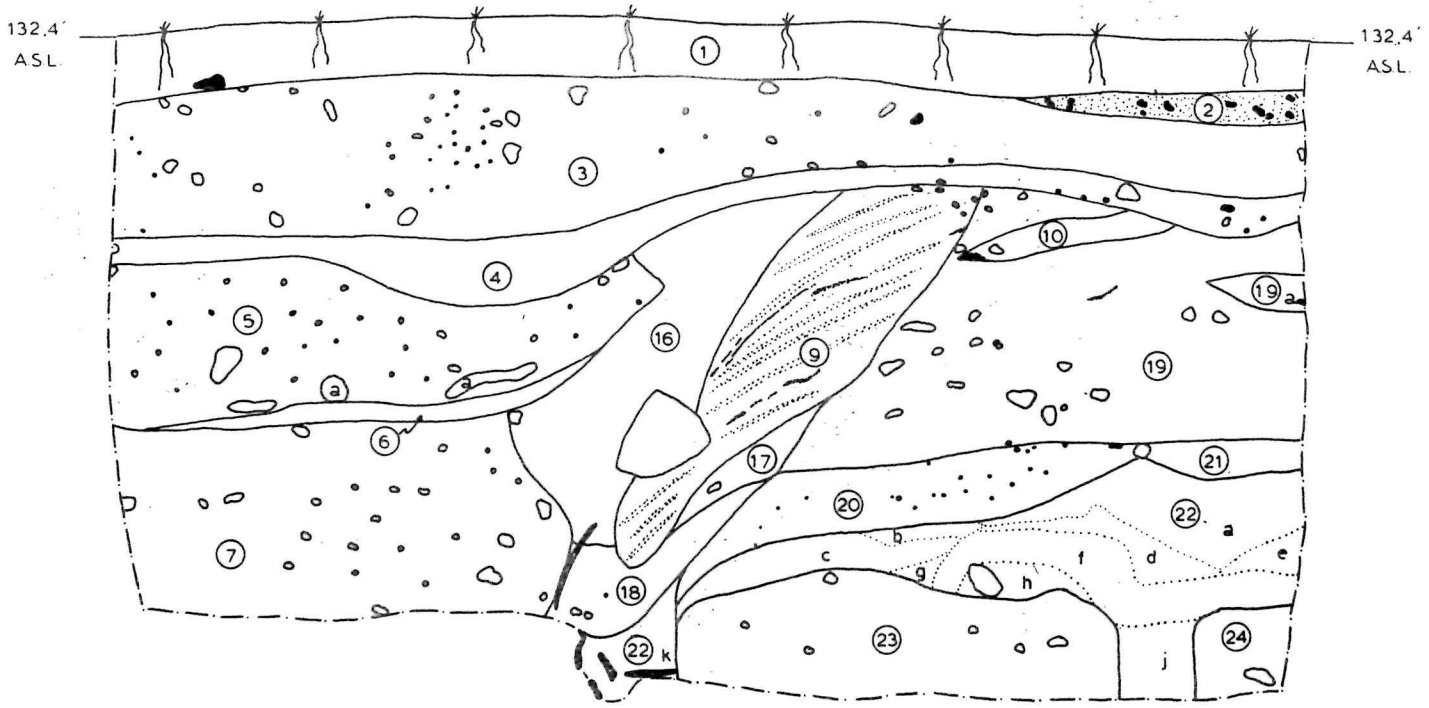

2E13G  
CROSS-SECTION  
WEST FACE

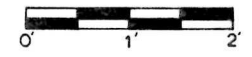

DRAWING 7

THIS IS A PLAN OF THE MEN'S BARRACKS, 2E16, AS SEEN AT THE  
END OF THE 1966 EXCAVATIONS. ITS CONTENTS ARE SELF-EXPLANATORY,  
AND ARE ITEMIZED IN FIGURE 4, P. 24 OF THIS REPORT.

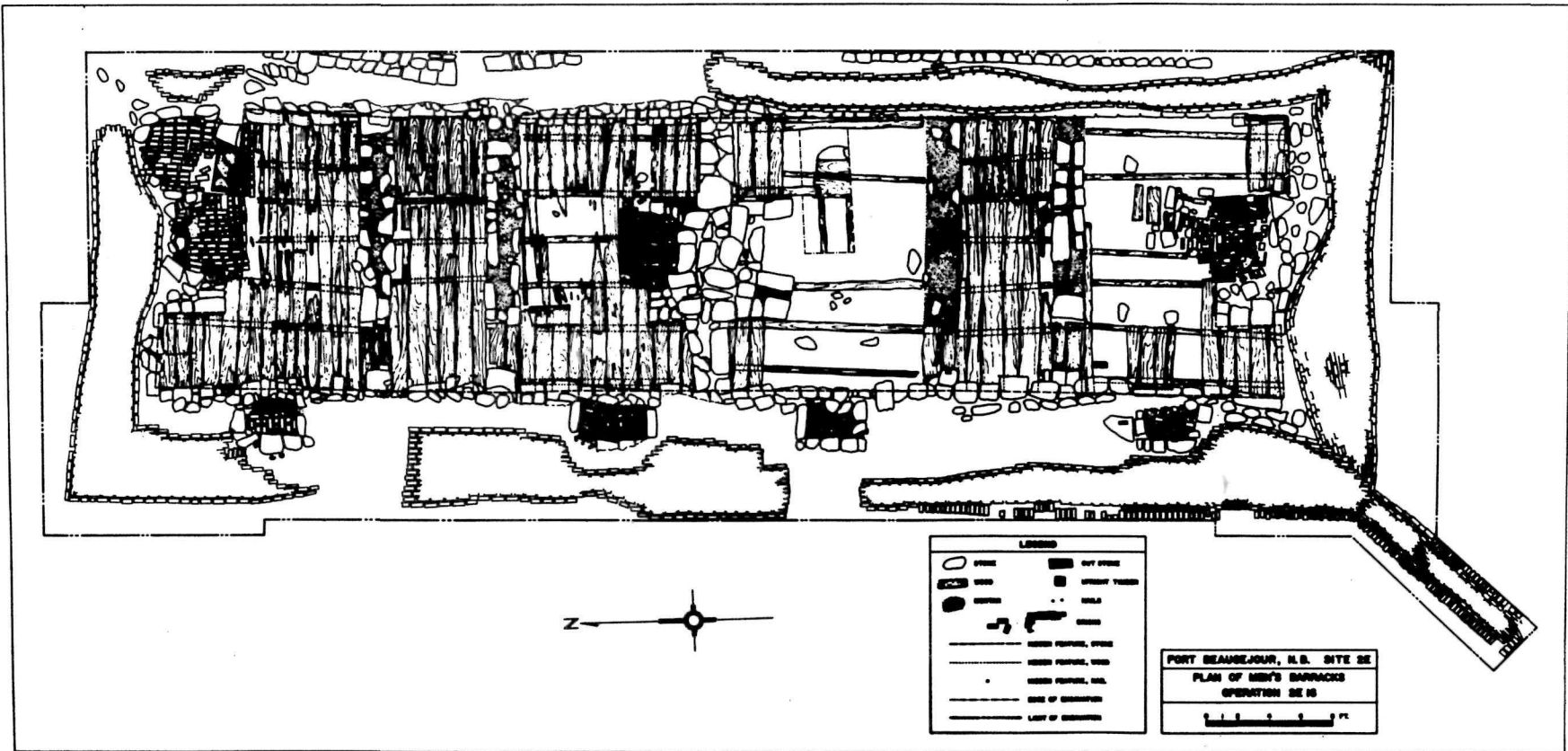

DRAWING 8

THIS IS A LONGITUDINAL CROSS-SECTION OF THE MEN'S BARRACKS, OPERATION 2E16, RUNNING FROM NORTH TO SOUTH. THOSE STONES WHICH ARE PARTS OF STRUCTURES ARE INDICATED BY DARKENED LINES; ALL OTHERS ARE RUBBLE. STRATIGRAPHY IS AS FOLLOWS:

1. 7.5YR 4/2 DARK BROWN TOPSOIL, WITH PEBBLES TO 0.2' MAXIMUM DIAMETER.
2. 5YR 3/4 DARK REDDISH BROWN HARD LOAMY SAND WITH ROCKS. THIS STRATUM SEEMS TO BE THE MAIN FILL OF THE PARADE SQUARE AND THE RAMPARTS, AND IS ONLY FOUND OUTSIDE THE WALLS OF THE BARRACKS.
3. 10YR 4/4 DARK YELLOWISH BROWN LOAMY SAND, WITH PEBBLES TO 0.1' MAXIMUM DIAMETER. THE STRATUM OFTEN HAS SOD MIXED INTO IT. ALTHOUGH THE ARTIFACTS IN THIS STRATUM APPEARED TO BE 19TH CENTURY IN ORIGIN, THE STRATUM HAS BEEN RECENTLY DEPOSITED HERE, AND WAS PROBABLY BROUGHT FROM ANOTHER PART OF THE SITE.
4. GRAY ASHES. THE ARTIFACTS FOUND IN THIS STRATUM ARE ALL MID-20TH CENTURY IN ORIGIN, AND WERE DEPOSITED HERE NO EARLIER THAN 1950.
5. 5YR 4/4 REDDISH BROWN LOAMY SAND. THIS APPEARS TO BE THE NORTHERN COUNTERPART OF STRATUM 4, AND ALTHOUGH IT CONTAINED NO RECENT ARTIFACTS IT IS PROBABLY A MODERN DEPOSIT.

6. 10YR 3/4 DARK YELLOWISH BROWN LOAMY SAND WITH PEBBLES TO 0.05' MAXIMUM DIAMETER.
- 6A. 7.5YR 4/4 DARK BROWN SLIGHTLY LOAMY SAND.
7. 7.5YR 4/2 DARK BROWN LOAMY SAND, SOD 1. THIS IS THE SOD STRATUM WHICH FIRST COVERED OVER THE COLLAPSED BARRACKS, AND MUST DATE TO THE LATTER HALF OF THE 19TH CENTURY.
8. 10YR 4/2 DARK GRAYISH BROWN SAND, WHICH IS MAINLY DECAYED MORTAR. THIS IS BUILDING RUBBLE, AND RESTS DIRECTLY ON THE FLOOR OF THE BARRACKS.
- 8A. 10YR 3/4 DARK YELLOWISH BROWN SAND.
9. COAL CLINKERS, SCRAPED FROM THE OVEN.

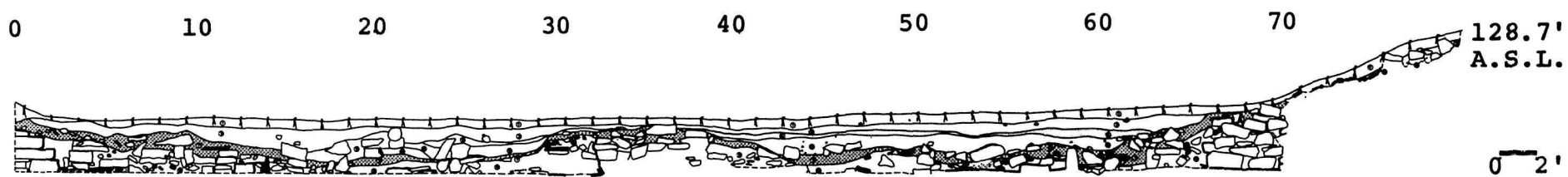

Drawing 8. 2E16 Longitudinal Cross-Section (Looking East)

**APPENDIX III**

**BRICKS**



DRAWING 9

THIS IS A TRANSVERSE CROSS-SECTION OF THE MEN'S BARRACKS, 2E16, LOOKING NORTH. IT IS ACTUALLY THE NORTH FACES OF 2E16L AND 2E16N, AND CONTAINS NO INSIDE STRUCTURES. STRATIGRAPHY IS IDENTICAL TO THAT DISCUSSED IN DRAWING 8:

1. 7.5YR 4/2 DARK BROWN TOPSOIL, WITH PEBBLES TO 0.2' MAXIMUM DIAMETER.
2. 5YR 3/4 DARK REDDISH BROWN HARD LOAMY SAND WITH ROCKS.
3. 10YR 4/4 DARK YELLOWISH BROWN LOAMY SAND, WITH PEBBLES TO 0.1' MAXIMUM DIAMETER.
4. GRAY ASHES.
6. 10YR 3/4 DARK YELLOWISH BROWN LOAMY SAND WITH PEBBLES TO 0.05' MAXIMUM DIAMETER.
7. 7.5YR 4/2 DARK BROWN LOAMY SAND, SOD 1.
8. 10YR 4/2 DARK GRAYISH BROWN SAND OR DECAYED MORTAR.

DRAWING 9

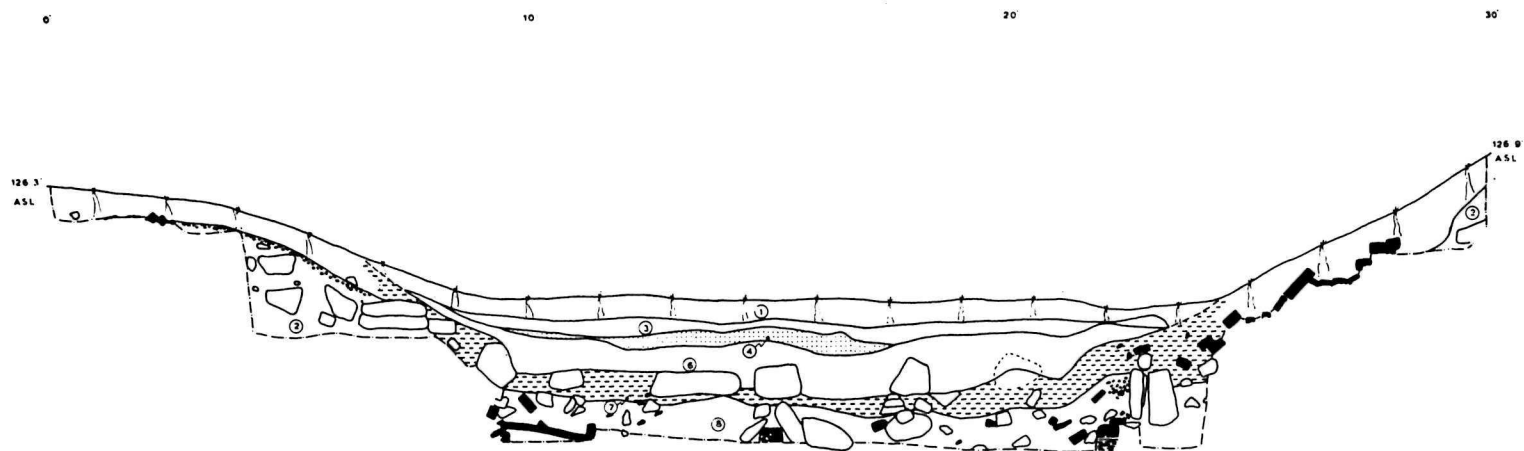

2E16

TRANSVERSE CROSS-SECTION

(Looking North)



69

DRAWING 10

THIS IS A TRANSVERSE CROSS-SECTION OF THE MEN'S BARRACKS, 2E16, WITH AN INSIDE STRUCTURE, NAMELY THE CENTRAL FIREPLACE. IT CONSISTS OF THE NORTH FACES OF 2E16J AND 2E16K. AGAIN, THE STRATIGRAPHY, THOUGH ARRANGED SLIGHTLY DIFFERENTLY, IS THE SAME BASICALLY AS THAT DISCUSSED IN DRAWING 8:

1. 7.5YR 4/2 DARK BROWN TOPSOIL, WITH PEBBLES TO 0.2' MAXIMUM DIAMETER.
2. 5YR 3/4 DARK REDDISH BROWN HARD LOAMY SAND WITH ROCKS.
  - 2A. RED BRICK CHIPS.
  - 2B. 7.5YR 4/4 DARK BROWN LOAMY SAND.
3. 10YR 4/4 DARK YELLOWISH BROWN LOAMY SAND, WITH PEBBLES TO 0.1' MAXIMUM DIAMETER.
6. 10YR 3/4 DARK YELLOWISH BROWN LOAMY SAND WITH PEBBLES TO 0.05' MAXIMUM DIAMETER.
7. 7.5YR 4/2 DARK BROWN LOAMY SAND, SOD 1.
8. 10YR 3/3 DARK BROWN SAND OR DECAYED MORTAR.
  - 8A. 10YR 4/2 DARK GRAYISH BROWN SAND OR DECAYED MORTAR.
9. WHITE MORTAR.

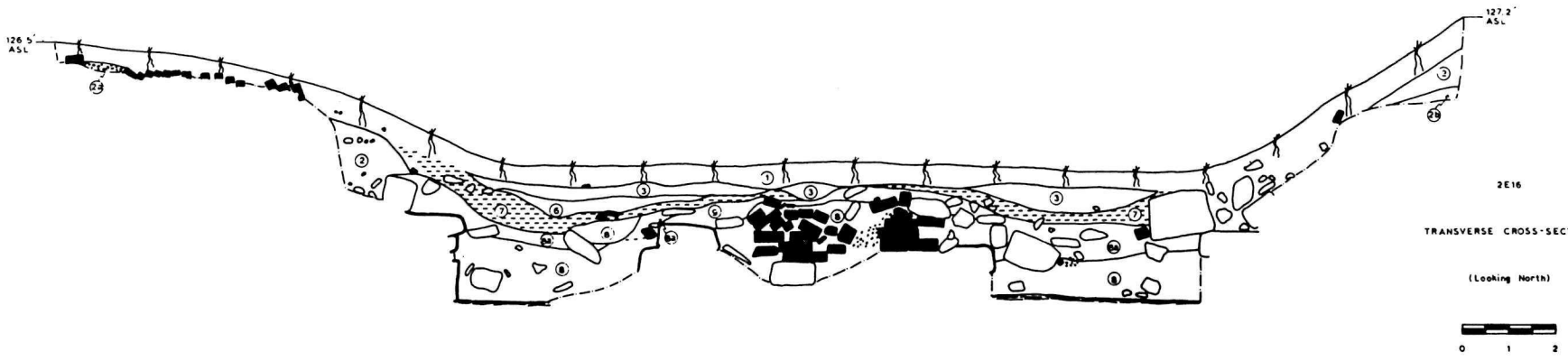

2E16

TRANSVERSE CROSS-SECTION

(Looking North)



THE FOLLOWING CHARTS ARE COMPARISONS OF LENGTH, WIDTH AND THICKNESS RESPECTIVELY OF BRICKS FROM VARIOUS PORTIONS OF OPERATIONS 2E16 AND 2E17.

THE FREQUENCY DISTRIBUTIONS IN THEMSELVES POINT OUT SOME SIMILARITIES AND DIFFERENCES. THE QUANTITIES HAVE NOT YET BEEN SUBJECTED TO STATISTICAL ANALYSIS, SO THE SIGNIFICANCE OF THE FREQUENCY DISTRIBUTIONS HAS NOT BEEN DETERMINED, NOR HAVE LESS EVIDENT PATTERNS OF SIMILARITY, WHICH MAY EXIST, BEEN REVEALED.

I THEREFORE PRESENT THE RAW DATA HERE, IN THE HOPE THAT SOMEONE MORE FAMILIAR WITH STATISTICS AND MORE CURIOUS ABOUT BRICKS THAN I MIGHT STUDY THE SUBJECT IN GREATER DETAIL.

2E BRICKS: COMPARISON OF LENGTH

■ ONE BRICK

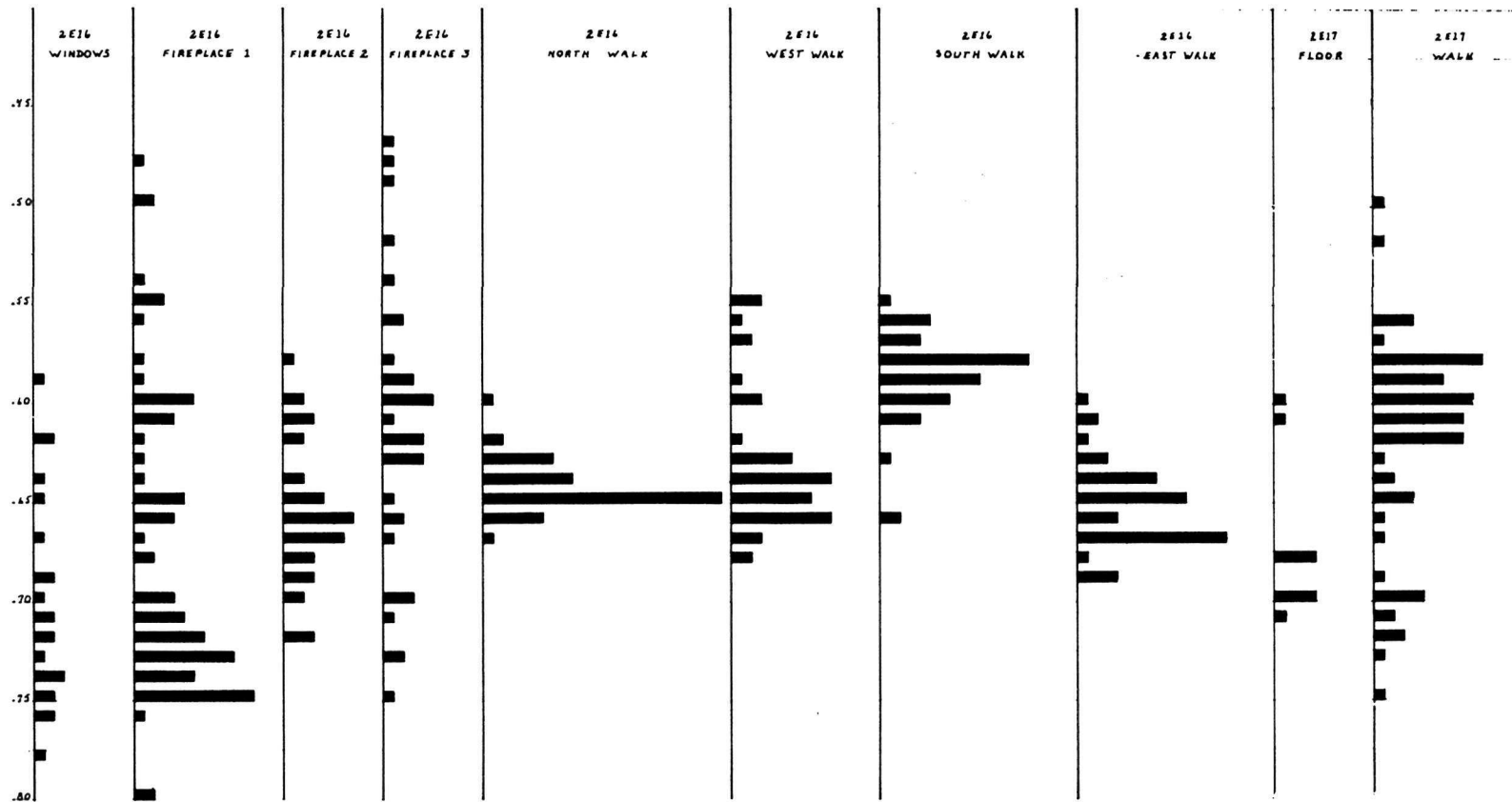

2E BRICKS: COMPARISON OF WIDTH

■ = ONE BRICK

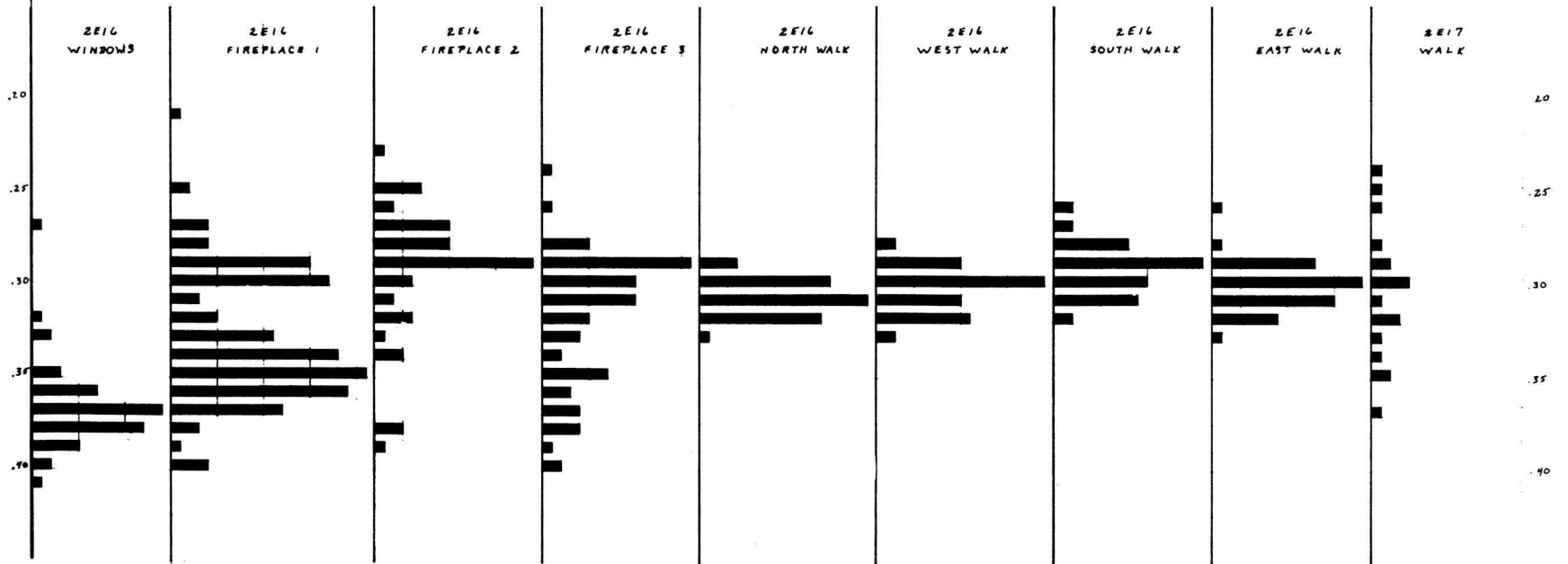

2E BRICKS COMPARISON OF THICKNESS

■ = ONE BRICK

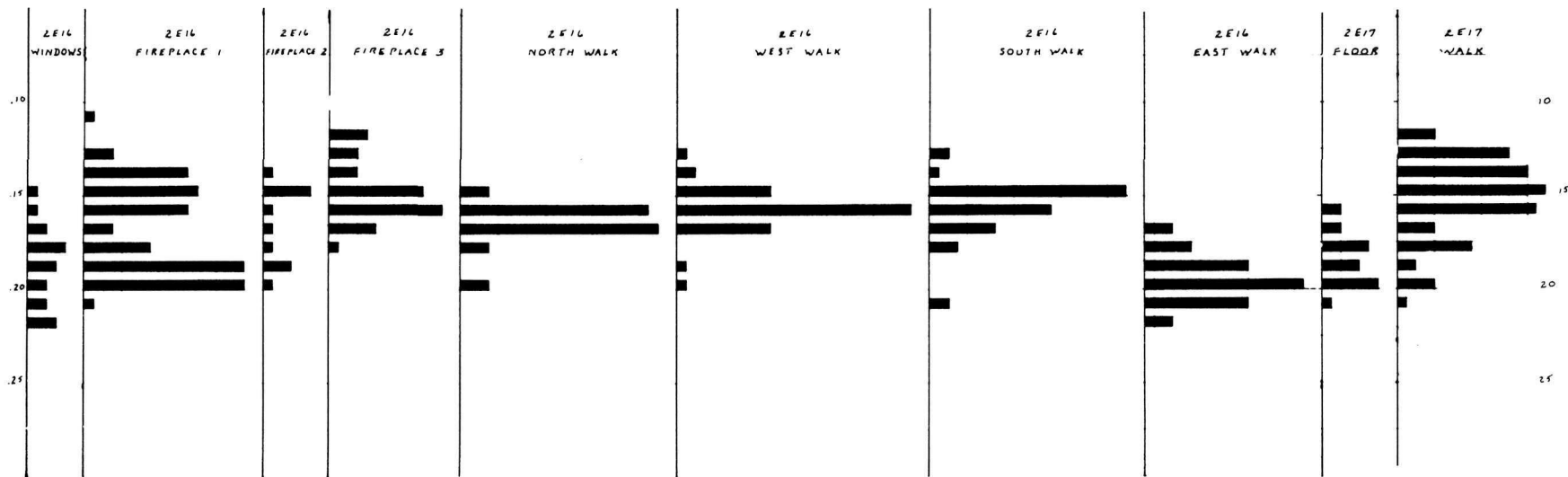



Contract number: 03KT A4104-5-0164

Imprimerie TURCOTTE Printers